

GARDNER + SEMLER
 LANDSCAPE ARCHITECTURE
 WWW.GSLADDESIGN.COM
 17670 NW 78th AVE., SUITE 214
 MIAMI, FL 33015
 P 305.392.1016 F 305.392.1019
 CORP. ID # 0000266

ARQUITECTONICA

2900 Oak Avenue, Miami, FL 33133
 T 305.372.1812 F 305.372.1175

ALL DESIGNS INDICATED IN THESE DRAWINGS ARE PROPERTY OF ARQUITECTONICA INTERNATIONAL CORP. NO COPIES, TRANSMISSIONS, REPRODUCTIONS OR ELECTRONIC MANIPULATION OF ANY PORTION OF THESE DRAWINGS IN THE WHOLE OR IN PART ARE TO BE MADE WITHOUT THE EXPRESS WRITTEN AUTHORIZATION OF ARQUITECTONICA INTERNATIONAL CORP. DESIGN INTENT SHOWN IS SUBJECT TO REVIEW AND APPROVAL OF ALL APPLICABLE LOCAL AND GOVERNMENTAL AUTHORITIES HAVING JURISDICTION. ALL COPYRIGHTS RESERVED © 2021.
 THE DATA INCLUDED IN THIS STUDY IS CONCEPTUAL IN NATURE AND WILL CONTINUE TO BE MODIFIED THROUGHOUT THE COURSE OF THE PROJECTS DEVELOPMENT WITH THE EVENTUAL INTEGRATION OF STRUCTURAL, MEP AND LIFE SAFETY SYSTEMS. AS THESE ARE FURTHER REFINED, THE NUMBERS WILL BE ADJUSTED ACCORDINGLY.

HPB FINAL SUBMITTAL
1509 - 1515 WASHINGTON AVE
MIAMI BEACH, FL 33139

Existing Tree Disposition Plan



SCALE: 1" = 25'



DATE:
 MAR 10, 2024

LA-101

EXISTING TREE DISPOSITION LIST								
KEY	BOTANICAL NAME	COMMON NAME	SIZE			DISPOSITION	CONDITION	MITIGATION
			HT.(ft.)	SPD.(ft.)	DBH.(in.)			DBH.(in.)
1	Cocos nucifera	Coconut Palm	30	12	7	remove	fair	7
2	Cocos nucifera	Coconut Palm	30	12	7	remove	fair	7
3	Cocos nucifera	Coconut Palm	30	12	7	remove	fair	7
4	Cocos nucifera	Coconut Palm	30	12	7	remove	fair	7
5	Cocos nucifera	Coconut Palm	30	12	7	remove	fair	7
6	Cocos nucifera	Coconut Palm	30	12	7	remove	fair	7
7	Cocos nucifera	Coconut Palm	30	12	7	remove	fair	7
8	Mangifera indica	Mango	13	6	1	remove	poor	
9	Mangifera indica	Mango	18	15	3	remove	fair	
10	Araucaria heterophylla	Norfolk Island Pine	45	25	9,9,10	remove	fair	28
TOTAL DBH INCHES TO BE REMOVED								28
TOTAL PALMS TO BE REMOVED								7
TOTAL TREES MITIGATION REQUIRED								10 trees (from hardwood removal) + 7 trees (from palm removals) = 17 trees
TOTAL TREES MITIGATION PROVIDED								24 trees
Mitigation is provided in the form of 8 Silver Buttonwoods, 10 Simpson's Stoppers and 6 Live Oaks.								

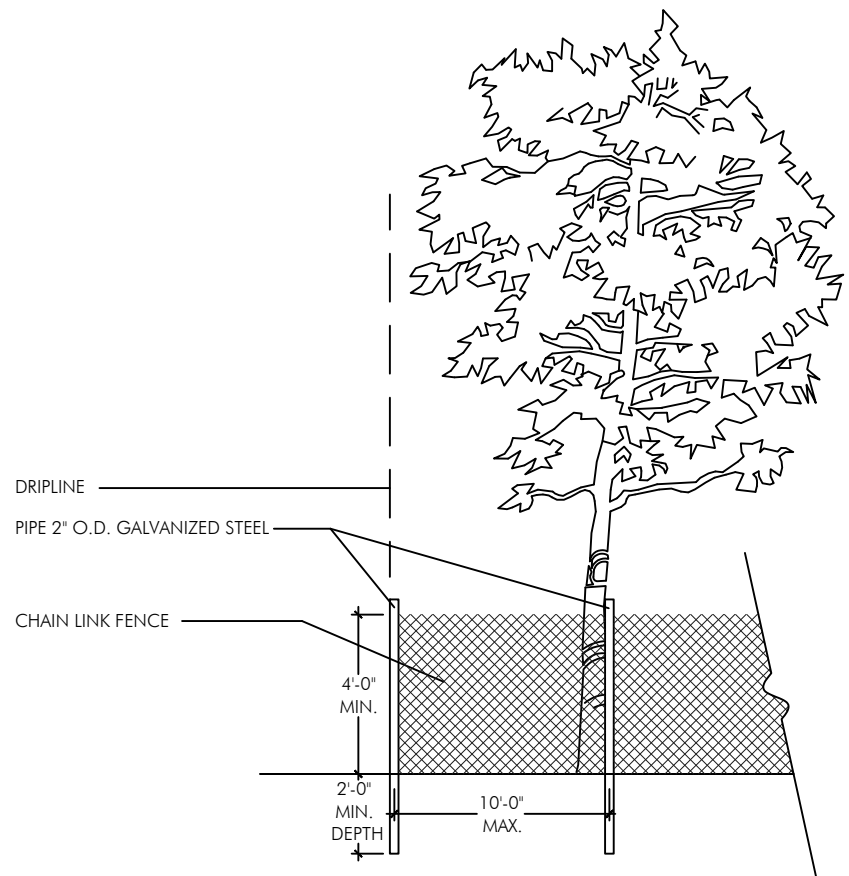

NOTES:
 -BARRIER SHALL BE PLACED AT THE EDGE OF THE DRIPLINE OF THE THE TREE CANOPY OR AS FAR FROM THE TREE AS POSSIBLE WHERE THE CANOPY OVERHANGS PAVEMENT THAT IS TO REMAIN. BARRIER SHALL BE MAINTAINED IN AN UPRIGHT POSITION AT ALL TIMES.
 -TREE PROTECTION FENCE (TPF) SHALL BE INSTALLED PRIOR TO ANY SITE WORK, CLEARING, OR DEMOLITION. AND MAINTAINED THROUGHOUT CONSTRUCTION.
 -REMOVE TPF ONLY WITH APPROVAL FROM URBAN FORESTER AFTER ALL SITE WORK HAS BEEN COMPLETED.

*NOTE: Should any existing trees or palms be damaged they shall be evaluated by the City Urban Forester to determine corrective actions that may include removal, corrective pruning and or replacement. Any corrective actions required shall be performed in accordance with the City of Miami Beach Code, the most current ANSI A-300 Pruning Standards and or an issued City Tree or Environmental Permit. Any corrective pruning required shall be performed by an ISA Certified Arborist and the City Urban Forester shall be consulted.

TREE PROTECTION DETAIL

N.T.S.



ARQUITECTONICA

2900 Oak Avenue, Miami, FL 33133
 T 305.372.1812 F 305.372.1175

ALL DESIGNS INDICATED IN THESE DRAWINGS ARE PROPERTY OF ARQUITECTONICA INTERNATIONAL CORP. NO COPIES, TRANSMISSIONS, REPRODUCTIONS OR ELECTRONIC MANIPULATION OF ANY PORTION OF THESE DRAWINGS IN THE WHOLE OR IN PART ARE TO BE MADE WITHOUT THE EXPRESS WRITTEN AUTHORIZATION OF ARQUITECTONICA INTERNATIONAL CORP. DESIGN INTENT SHOWN IS SUBJECT TO REVIEW AND APPROVAL OF ALL APPLICABLE LOCAL AND GOVERNMENTAL AUTHORITIES HAVING JURISDICTION. ALL COPYRIGHTS RESERVED © 2021. THE DATA INCLUDED IN THIS STUDY IS CONCEPTUAL IN NATURE AND WILL CONTINUE TO BE MODIFIED THROUGHOUT THE COURSE OF THE PROJECTS DEVELOPMENT WITH THE EVENTUAL INTEGRATION OF STRUCTURAL, MEP AND LIFE SAFETY SYSTEMS. AS THESE ARE FURTHER REFINED, THE NUMBERS WILL BE ADJUSTED ACCORDINGLY.

HPB FINAL SUBMITTAL
 1509 - 1515 WASHINGTON AVE
 MIAMI BEACH, FL 33139

Existing Tree Disposition List

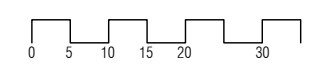

DATE:
 MAR 10, 2024

LA-102

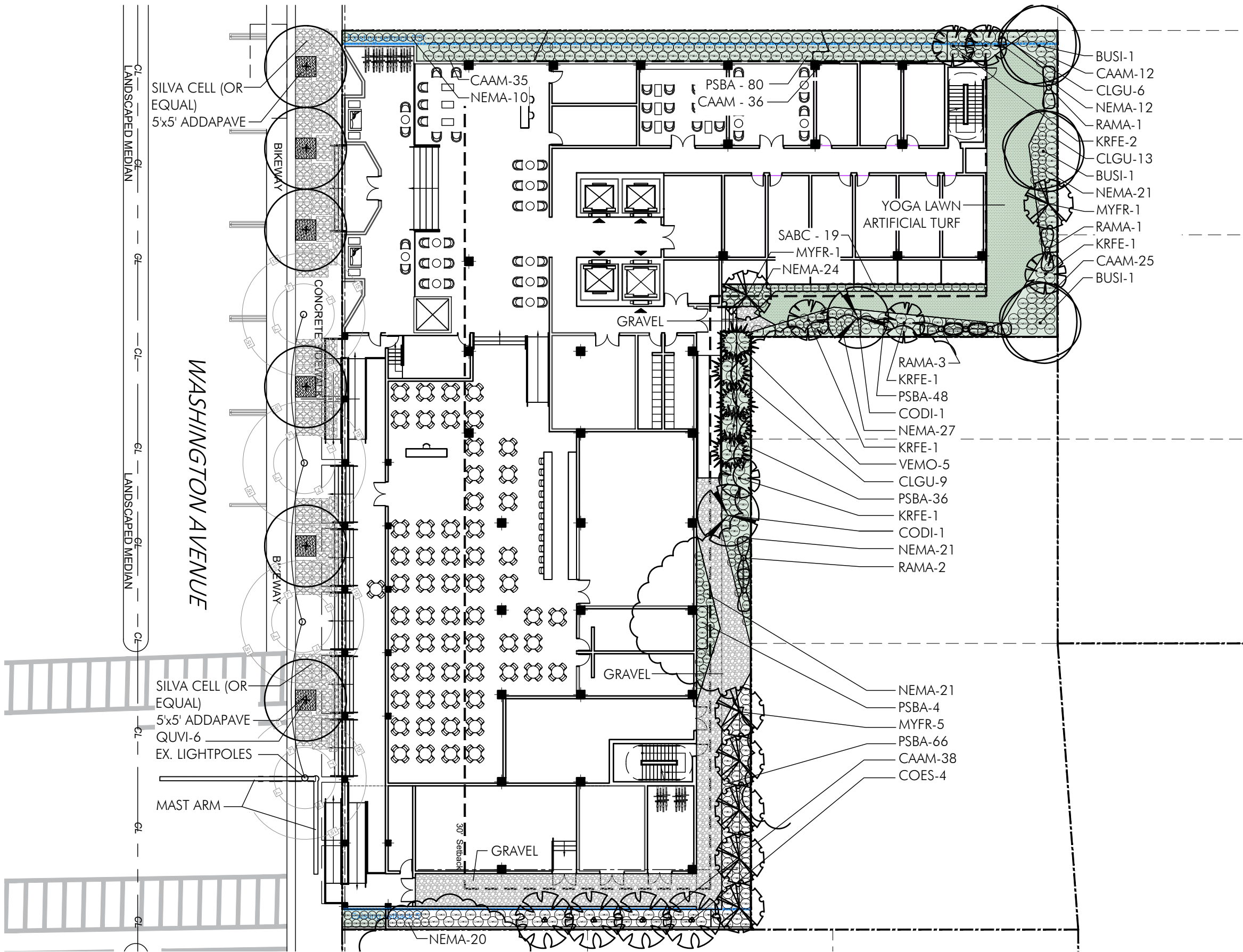

PLANT LIST - Ground Floor				
TREES				
KEY	PLANT NAME	QTY.	UT.	SIZE
BUSI	Bursera simaruba ..Gumbo Limbo	3	ea.	16' tall x 5' spread, 4" min. DBH
CODI	Coccoloba diversifolia ..Pigeon Plum	2	ea.	12' tall x 6' spread, 2" min. DBH
COES	Conocarpus erectus "Sericeus" ..Silver Buttonwood	4	ea.	12' tall x 6' spread, 2" min. DBH
KRFE	Krugiodendron ferreum ..Ironwood	6	ea.	12' tall x 6' spread, 2" min. DBH
MYFR	Myrcianthes fragrans ..Simpson's Stopper	7	ea.	12' tall x 6' spread, 2" min. DBH
QUVI	Quercus virginiana "Highrise" ..Highrise Live Oak	6	ea.	16' tall x 5' spread, 4" min. DBH
PALMS				
KEY	PLANT NAME	QTY.	UT.	SIZE
VEMO	Veitchia montgomeryana ..Montgomery Palm	5	ea.	16'-18' tall overall, singles
OTHER				
KEY	PLANT NAME	QTY.	UT.	SIZE
RAMA	Ravenea madagascariensis ..Traveller's Palm	7	ea.	14'-16' tall overall
SHRUBS				
KEY	PLANT NAME	QTY.	UT.	SIZE
CAAM	Callicarpa americana ..Beautyberry	146	ea.	24" x 24"
CLGU	Clusia guttifera ..Dwarf Pitch Apple	30	ea.	72" tall x 36" spread
NEMA	Nephrolepis exaltata "Macho" ..Macho Fern	171	ea.	24" x 24"
PSBA	Psychotria bahamensis ..Wild Coffee	199	ea.	24" x 24"
SABC	Sansevieria trifasciata "Black Coral" ..Black Coral Snake Plant	19	ea.	18" x 12"
MISCELLANEOUS				
	Planting Soil: 70% Silica Sand 20% Everglades Muck 10% Shredded Pinebark	as req.	c.y.	excavate and backfill 18" depth in all planting areas.
	Shredded Melaleuca Mulch	as req.	c.y.	3" layer in all shrub beds

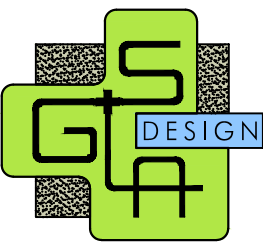

GARDNER + SEMLER
LANDSCAPE ARCHITECTURE
WWW.GSLDESIGN.COM
17670 NW 78th AVE., SUITE 214
MIAMI, FL 33015
P 305.392.1016 F 305.392.1019
CORP. 1D#0000266

ARQUITECTONICA

2900 Oak Avenue, Miami, FL 33133
T 305.372.1812 F 305.372.1175

ALL DESIGNS INDICATED IN THESE DRAWINGS ARE PROPERTY OF ARQUITECTONICA INTERNATIONAL CORP. NO COPIES, TRANSMISSIONS, REPRODUCTIONS OR ELECTRONIC MANIPULATION OF ANY PORTION OF THESE DRAWINGS IN THE WHOLE OR IN PART ARE TO BE MADE WITHOUT THE EXPRESS WRITTEN AUTHORIZATION OF ARQUITECTONICA INTERNATIONAL CORP. DESIGN INTENT SHOWN IS SUBJECT TO REVIEW AND APPROVAL OF ALL APPLICABLE LOCAL AND GOVERNMENTAL AUTHORITIES HAVING JURISDICTION. ALL COPYRIGHTS RESERVED © 2021.
THE DATA INCLUDED IN THIS STUDY IS CONCEPTUAL IN NATURE AND WILL CONTINUE TO BE MODIFIED THROUGHOUT THE COURSE OF THE PROJECTS DEVELOPMENT WITH THE EVENTUAL INTEGRATION OF STRUCTURAL, MEP AND LIFE SAFETY SYSTEMS. AS THESE ARE FURTHER REFINED, THE NUMBERS WILL BE ADJUSTED ACCORDINGLY.

HPB FINAL SUBMITTAL
1509 - 1515 WASHINGTON AVE
MIAMI BEACH, FL 33139

Ground Floor Planting Plan

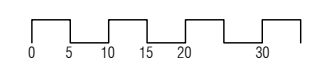

SCALE: 1" = 25'



DATE:
MAR 10, 2024

LA-103

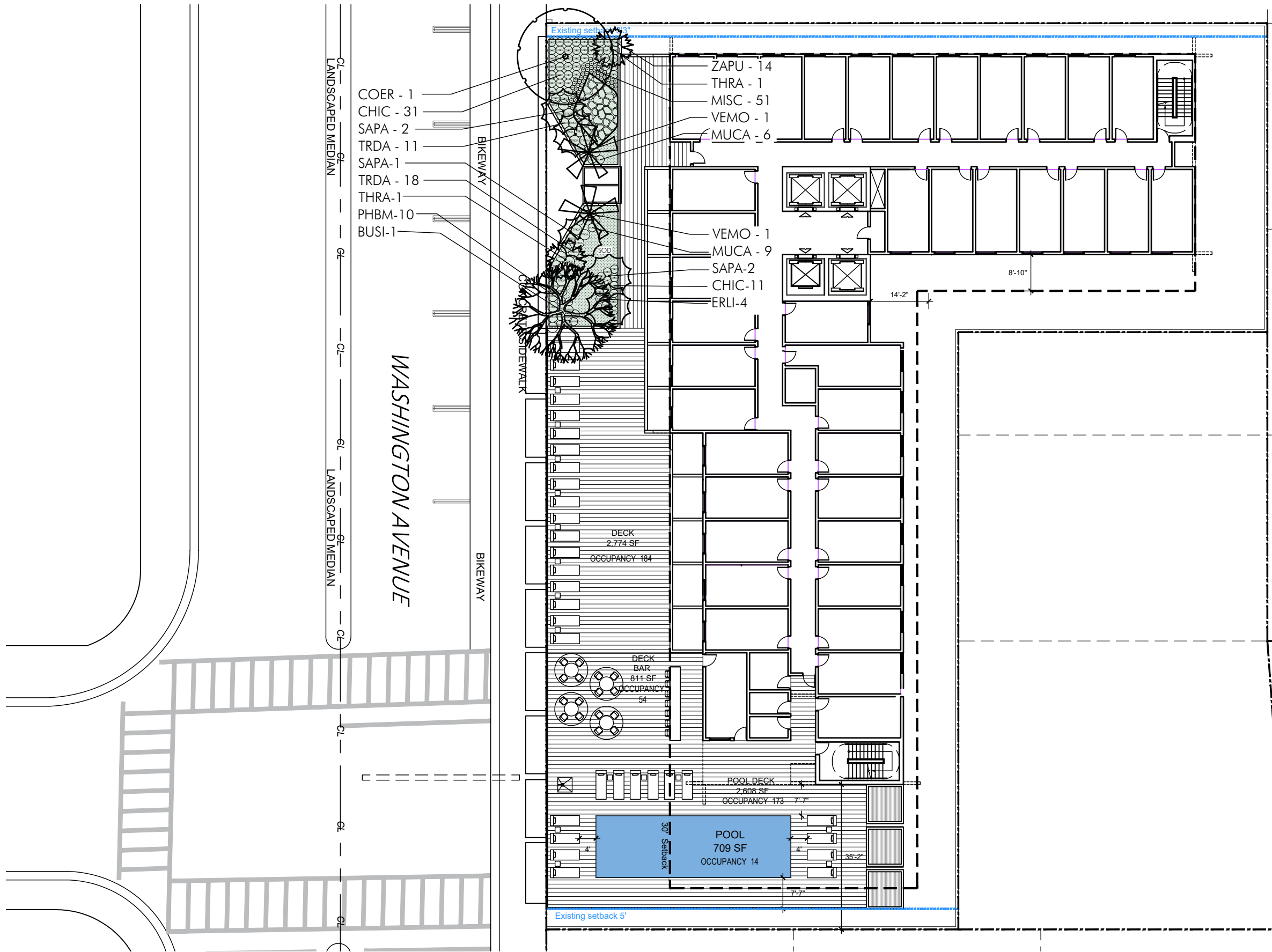

PLANT LIST - Second Floor				
TREES				
KEY	PLANT NAME	QTY.	UT.	SIZE
BUSI	Bursera simaruba ...Gumbo Limbo	1	ea.	16' tall x 5' spread, 4" min. DBH
COER	Conocarpus erectus ...Green Buttonwood	1	ea.	14' tall x 6' spread, 2" min. DBH
PALMS				
KEY	PLANT NAME	QTY.	UT.	SIZE
SAPA	Sabal palmetto ...Sabal Palm	5	ea.	3 at 18', 5 at 24', 2 at 30' tall OA, smooth curved/character trunks, /3 hurricane cut mixed sizes in groups
THRA	Thrinax radiata ...Florida Thatch Palm	2	ea.	6' tall OA
VEMO	Veitchia montgomeryana ...Montgomery Palm	2	ea.	16'-18' tall overall, singles
SHRUBS				
KEY	PLANT NAME	QTY.	UT.	SIZE
CHIC	Chrysobalanus icaco ...Horizontal Cocoplum	42	ea.	18" x 18"
ERLI	Emodea littoralis ...Golden Creeper	4	ea.	3 gal cans, full
MUCA	Muhlenbergia capillaris ...Muhly Grass	15	ea.	18" x 18"
PHBM	Philodendron var. 'Burle marx' ...Burle Marx Philodendron	10	ea.	18" x 18"
SERE	Sereoa repens 'Silver' ...Saw Palmetto	12	ea.	24" x 24"
TRDA	Tripsacum dactyloides ...Fakahatchee Grass	30	ea.	3 gal cans, full
ZAPU	Zamia pumila ...Coontie	14	ea.	18" x 18"
GROUNDCOVERS				
KEY	PLANT NAME	QTY.	UT.	SIZE
MISC	Microsorium scolopendria ...Wart Fern	51	ea.	1 gallon cans, full
MISCELLANEOUS				
	Roof Planter Soil Mix 25% Coarse Sand 25% Medium Sand 20% Rice Rock	as req.	c.y.	Roofplanter depth to be at a minimum of 3'-6".
	Shredded Melaleuca Mulch	as req.	c.y.	3" layer in all shrub beds

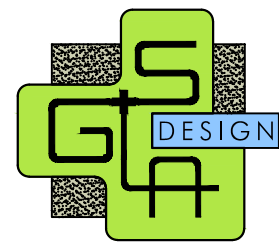

GARDNER + SEMLER
LANDSCAPE ARCHITECTURE
WWW.GSLDESIGN.COM
17670 NW 78th AVE., SUITE 214
MIAMI, FL 33015
P 305.392.1016 F 305.392.1019
CORP. ID # 0000266

ARQUITECTONICA

2900 Oak Avenue, Miami, FL 33133
T 305.372.1812 F 305.372.1175

ALL DESIGNS INDICATED IN THESE DRAWINGS ARE PROPERTY OF ARQUITECTONICA INTERNATIONAL CORP. NO COPIES, TRANSMISSIONS, REPRODUCTIONS OR ELECTRONIC MANIPULATION OF ANY PORTION OF THESE DRAWINGS IN THE WHOLE OR IN PART ARE TO BE MADE WITHOUT THE EXPRESS WRITTEN AUTHORIZATION OF ARQUITECTONICA INTERNATIONAL CORP. DESIGN INTENT SHOWN IS SUBJECT TO REVIEW AND APPROVAL OF ALL APPLICABLE LOCAL AND GOVERNMENTAL AUTHORITIES HAVING JURISDICTION. ALL COPYRIGHTS RESERVED © 2021.
THE DATA INCLUDED IN THIS STUDY IS CONCEPTUAL IN NATURE AND WILL CONTINUE TO BE MODIFIED THROUGHOUT THE COURSE OF THE PROJECTS DEVELOPMENT WITH THE EVENTUAL INTEGRATION OF STRUCTURAL, MEP AND LIFE SAFETY SYSTEMS. AS THESE ARE FURTHER REFINED, THE NUMBERS WILL BE ADJUSTED ACCORDINGLY.

HPB FINAL SUBMITTAL
1509 - 1515 WASHINGTON AVE
MIAMI BEACH, FL 33139

Second Floor Planting Plan

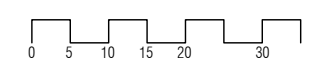

SCALE: 1" = 25'



DATE:
MAR 10, 2024

LA-104

CITY OF MIAMI BEACH		
LANDSCAPE LEGEND		
INFORMATION REQUIRED TO BE PERMANENTLY AFFIXED TO PLANS		
Zoning District CD-2	Lot Area 0.63	Acres 27,625
	REQUIRED/ ALLOWED	PROVIDED
OPEN SPACE		
A. Square feet of required Open Space as indicated on site plan: Lot Area = $27,625 \text{ s.f.} \times \text{N/A} \% = \text{N/A s.f.}$	N/A	N/A
B. Square feet of parking lot open space required as indicated on site		
Number of parking spaces $0 \times 10 \text{ s.f. parking space} =$	0	0
C. Total square feet of landscaped open space required: $A+B=$	N/A	N/A
LAWN AREA CALCULATION		
A. Square feet of landscaped open space required		
B. Maximum lawn area (sod) permitted = $\text{N/A} \% \times \text{N.A s.f.}$	N/A	N/A
TREES		
A. Number of trees required per lot or net lot acre, less existing number of trees meeting minimum requirements = 22 trees / acre $(22 \times 0.63 \text{ acres} = 14 \text{ trees})$	14	22
B. % Natives required: Number of trees provided $\times 30\% =$	5	22
C. % Low maintenance / drought and salt tolerant required: Number of trees provided $\times 50\% =$	7	22
D. Street Trees (maximum average spacing of 20' o.c.) $220 \text{ linear feet along street divided by } 20' =$	11	6 (insufficient room to add more due to utilities)
E. Street tree species allowed directly beneath power lines: (maximum average spacing of 20' o.c.): $200 \text{ linear feet along street divided by } 20' =$	N/A	N/A
SHRUBS		
A. Number of shrubs required: Sum of lot and street trees required \times	300	564
B. % Native shrubs required: Number of shrubs provided $\times 50\% =$	150	365
LARGE SHRUBS OR SMALL TREES		
A. Number of large shrubs or small trees required: Number of required shrubs $\times 10\% =$	30	30
B. % Native large shrubs or small trees required: Number of large shrubs or small trees provided $\times 50\% =$	15	30

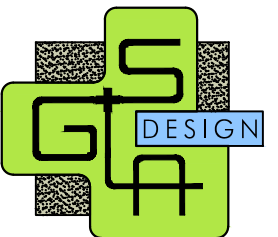

GARDNER + SEMLER
LANDSCAPE ARCHITECTURE
WWW.GSLADDESIGN.COM
17670 NW 78th AVE., SUITE 214
MIAMI, FL 33015
P 305.392.1016 F 305.392.1019
CORP. ID # 0000266

ARQUITECTONICA

2900 Oak Avenue, Miami, FL 33133
T 305.372.1812 F 305.372.1175

ALL DESIGNS INDICATED IN THESE DRAWINGS ARE PROPERTY OF ARQUITECTONICA INTERNATIONAL CORP. NO COPIES, TRANSMISSIONS, REPRODUCTIONS OR ELECTRONIC MANIPULATION OF ANY PORTION OF THESE DRAWINGS IN THE WHOLE OR IN PART ARE TO BE MADE WITHOUT THE EXPRESS WRITTEN AUTHORIZATION OF ARQUITECTONICA INTERNATIONAL CORP. DESIGN INTENT SHOWN IS SUBJECT TO REVIEW AND APPROVAL OF ALL APPLICABLE LOCAL AND GOVERNMENTAL AUTHORITIES HAVING JURISDICTION. ALL COPYRIGHTS RESERVED © 2021.
THE DATA INCLUDED IN THIS STUDY IS CONCEPTUAL IN NATURE AND WILL CONTINUE TO BE MODIFIED THROUGHOUT THE COURSE OF THE PROJECTS DEVELOPMENT WITH THE EVENTUAL INTEGRATION OF STRUCTURAL, MEP AND LIFE SAFETY SYSTEMS. AS THESE ARE FURTHER REFINED, THE NUMBERS WILL BE ADJUSTED ACCORDINGLY.

HPB FINAL SUBMITTAL
1509 - 1515 WASHINGTON AVE
MIAMI BEACH, FL 33139

Landscape Legend & Plant List



SCALE: 1" = 25'

DATE:
MAR 10, 2024

LA-105

LANDSCAPE SPECIFICATIONS
PART 1 - GENERAL

1.1 SCOPE

A. Contractor shall provide all labor, materials, equipment, supervision, and related work necessary to complete the landscape work in accordance with the intent of the landscape plans, schedules and these specifications. The extent of work is shown on the drawings which are a part of this document.

1.2 CONTRACTOR QUALIFICATIONS

A. Landscape installation work to be performed by a Contractor Certified by the Florida Nurserymen, Growers and Landscape Association (FNGLA) as a Certified Landscape Contractor. Any pruning to be supervised by an Arborist, certified by the International Society of Arboriculture (ISA) and licensed in County where work is performed.

1.3 INVESTIGATION OF UTILITIES

A. Prior to beginning work, the Contractor shall be responsible to locate existing underground utilities. Check with all utility companies and Sunshine State, call (811).

1.4 SUBSTITUTIONS

A. Only materials specified will be accepted, unless approved in writing by the Landscape Architect in advance.

1.5 PLANT SIZES

A. All plant sizes shall equal or exceed the minimum sizes as specified in the plant list. If plant sizes of local codes and ordinances require larger plant material than specified on plans, then they shall supercede the sizes on the plan. When plant sizes are specified as a range of size, installed materials shall average the mean of the range specified. Plants shall be measured following pruning, with branches in normal position. All necessary pruning shall be done at the time of planting.

1.6 PLANT QUALITY

A. All plant material shall be equal to or better than Florida No. 1 as classified by "Grades and Standards for Nursery Plants" by the Division of Plant Industry, Florida Department of Agriculture. They shall have a growth habit that is normal for the species; healthy, vigorous, free from insects, disease and injury.

B. The Owner or Landscape Architect reserves the right to refuse any plant material which does not conform to the intent of the written specifications or design.

C. CIRCLING ROOTS FOUND ON CONTAINER-GROWN MATERIAL WILL NOT BE ACCEPTED UNLESS REMEDIAL ROOT PRUNING, APPROVED BY THE LANDSCAPE ARCHITECT IS DONE BEFORE PLANTING.

1.7 PLANT QUANTITY

A. The plant quantities shown on the plant list are to be used only as an aid to bidders. In the case of discrepancy between the plant list and the plan, the quantity on the plan shall override the plant list.

1.8 UNIT PRICES

A. The successful bidder shall furnish to the Owner and the Landscape Architect, a unit price breakdown for all materials. The Owner may, at his discretion, add to or delete from the materials utilizing the unit price breakdown submitted to and accepted by the Owner.

1.9 SUBMITTALS

A. Fertilizer: The Contractor shall submit to the Owner and Landscape Architect documentation that all the fertilizer used for the project is of the analysis specified and placed at the rates specified in section 2.2 FERTILIZER.

B. Planting soil: The Contractor shall submit a sample of the planting soil (approximately 1 cu. ft.) for approval by the Landscape Architect prior to delivery to the site.

1.10 CLEAN-UP & MAINTENANCE OF TRAFFIC

A. Follow procedures in FDOT Index 600 for maintenance of traffic during construction.

B. At the end of each work day, the Contractor shall remove debris and shall barricade the un-filled holes in a manner appropriate in the path of pedestrians and motorists.

C. Upon completion of the work or any major portion of the work or as directed by the Landscape Architect, all debris and surplus material from his work shall be removed from the job site.

1.11 MAINTENANCE PRIOR TO ACCEPTANCE

A. The Contractor is responsible to maintain the plantings until they are accepted under the provisions of 1.12 "ACCEPTANCE OF INSTALLATION".

1. Plants: Begin maintenance immediately following the final plant installation operation for each plant and continue until all plant installation is complete and accepted. Maintenance shall include watering all plants, weeding, mulching, pest and disease control, tightening and repairing of guys, repair of braces, removal of dead growth, resetting of plants to proper grade or up-right position, restoration of plant saucer, litter pick-up in plant beds and other necessary operations to assure specified minimum grade of Florida No. 1.

2. Turf Areas: Begin maintenance of turf immediately following the placement of sod and continue until sod installation is complete and accepted. Maintenance shall include but not be limited to, watering, leveling, mowing, weed and pest control, fungus and disease control and other necessary operations as determined by the Landscape Architect and good nursery practice.

3. Re-setting or straightening trees and palms: The Contractor shall re-set and/or straighten trees and palms as required at no additional cost to the Owner unless caused by sustained winds of 75 mph or more. Then, the costs of the operations may be charged to the owner. Re-set trees within 48 hours.

1.12 ACCEPTANCE OF INSTALLATION

A. Inspection: Inspection of the work, to determine completion of contract work, exclusive of the possible replacement of plants and turf, will be made by the Landscape Architect at the conclusion of the maintenance period. Written notice requesting such an inspection and submitted by the Contractor at least ten (10) days prior to the anticipated date.

1.13 GUARANTEE

A. Guarantee all plants for a period of one year (CCD). Guarantee shall commence from the date of written acceptance. Plant material which is on the site and scheduled to be relocated is not covered by the guarantee except in the case of Contractor's negligence or work that has been done in an unworkman-like manner. The Contractor is not responsible for loss due to acts of god, (i.e.) sustained winds of 75 mph or more, floods, frost, lightning, vandalism or theft.

1.14 REPLACEMENT

A. Replacement shall be made during the guarantee period as directed by the Landscape Architect within ten (10) days from time of notification. For all replacement plant material, the guarantee period shall extend for an additional forty-five (45) days beyond the original guarantee period. The Contractor shall be responsible to provide water to the replacement plants in sufficient quantity to aid in their establishment. At the end of the guarantee period, inspection will be made by the Landscape Architect, upon written notice requesting such inspection and submitted by the Contractor at least five (5) days before the anticipated date. Replacement plants must meet the requirements of Florida No. 1 at time of inspection. Remove from the site all plants that are dead or in a state of unsatisfactory growth, as determined by the Landscape Architect. Replace these and any plants missing due to the Contractor's negligence as soon as conditions permit.

1. Materials and Operations: All replacement plants shall be of the same kind and size as indicated on the plant list. The Contractor shall supply and plant the plants as specified under planting operations.

2. Cost of Replacements: A sum sufficient to cover the estimated cost of possible replacements, including material and labor will be retained by the Owner and paid to the Contractor after all replacements have been satisfactorily made and approved by the Landscape Architect.

PART 2 - MATERIALS

2.1 PLANTING SOIL

A. Planting soil for trees, shrubs and ground covers shall be of the composition noted on the plans, measured by volume.

B. Soil for Sodded Areas: shall be coarse lawn sand.

2.2 FERTILIZER

A. Fertilizer for trees, palms, shrubs, and groundcovers shall be as follows: LESCO Palm Special 13-3-13 or equal, Sulfur coated with iron and other minor elements and maximum of 2% chlorine, or brand with equal analysis. The fertilizer shall be uniform in composition, dry and free flowing and shall be delivered to the site in the original unopened containers, bearing the manufacturer's guaranteed analysis. Fertilizer for sod and seeded areas shall be 8-6-8, 50% organically derived nitrogen, or equal.

2.3 WATER

A. The Contractor shall provide potable water on site, available from the start of planting. The Contractor is responsible to ascertain the location and accessibility of the water source. The Contractor is responsible to provide the means of distribution (i.e. water truck, hoses, etc.) for distribution of water to the planting areas.

2.4 MULCH

A. Mulch shall be as specified on the Plant List.

2.5 ROOT BARRIER MATERIAL

A. Root barrier material shall be 24" deep polypropolyene panels by DeepRoot or approved equal.
B. Install per details in the plans.

PART 3 - INSTALLATION PROCEDURES

3.1 LAYOUT

A. Verify location of all underground utilities and obstructions prior to excavation.

3.2 HERBICIDE TREATMENT

1. In all areas infected with weed and/or grass growth, a systemic herbicide shall be applied per manufacturer's rates. When it has been established where work will be done, the systemic herbicide shall be applied in accordance with manufacturer's labeling to kill all noxious growth. Contractor shall schedule his work to allow more than one application to obtain at least 95% kill of undesirable growth. If necessary, Contractor shall conduct a test to establish suitability of product and applicator to be used on this project, prior to execution of the full application.



GARDNER + SEMLER
LANDSCAPE ARCHITECTURE
WWW.GSLADDESIGN.COM
17670 NW 78th AVE., SUITE 214
MIAMI, FL 33015
P 305.392.1016 F 305.392.1019
CORP. 1 D # 0 0 0 0 2 6 6

ARQUITECTONICA

2900 Oak Avenue, Miami, FL 33133
T 305.372.1812 F 305.372.1175

ALL DESIGNS INDICATED IN THESE DRAWINGS ARE PROPERTY OF ARQUITECTONICA INTERNATIONAL CORP. NO COPIES, TRANSMISSIONS, REPRODUCTIONS OR ELECTRONIC MANIPULATION OF ANY PORTION OF THESE DRAWINGS IN THE WHOLE OR IN PART ARE TO BE MADE WITHOUT THE EXPRESS WRITTEN AUTHORIZATION OF ARQUITECTONICA INTERNATIONAL CORP. DESIGN INTENT SHOWN IS SUBJECT TO REVIEW AND APPROVAL OF ALL APPLICABLE LOCAL AND GOVERNMENTAL AUTHORITIES HAVING JURISDICTION. ALL COPYRIGHTS RESERVED © 2021.
THE DATA INCLUDED IN THIS STUDY IS CONCEPTUAL IN NATURE AND WILL CONTINUE TO BE MODIFIED THROUGHOUT THE COURSE OF THE PROJECTS DEVELOPMENT WITH THE EVENTUAL INTEGRATION OF STRUCTURAL, MEP AND LIFE SAFETY SYSTEMS. AS THESE ARE FURTHER REFINED, THE NUMBERS WILL BE ADJUSTED ACCORDINGLY.

HPB FINAL SUBMITTAL
1509 - 1515 WASHINGTON AVE
MIAMI BEACH, FL 33139

Landscape Specifications



SCALE: 1" = 25'



DATE:
MAR 10, 2024

LA-106

3.3 PLANT PIT EXCAVATION AND BACKFILLING

- A. Trees: See the Planting and Bracing Details and notes.
- B. All planting holes shall be hand dug where machine dug holes may adversely affect utilities or improvements.
- C. Shrubs and Groundcover: Shrubs and groundcover shall be planted in a soil bed as described in the notes and details. Space shrubs and provide setback from curb and pavements as shown in the plans.
- D. Watering of field-grown plants: Thoroughly puddle in water to remove any air pockets in the plant hole.

3.4 WATERING

- A. The Contractor is responsible to provide the water for all new plants and transplants and means of distribution (i.e. hand watering or water truck) during the maintenance period and extending into the period after acceptance until the full schedule as listed below is complete. Water for trees and other large field grown plants shall be supplemented by hand or water truck, in addition to the irrigation system, (if one is provided). Contractor can adjust watering schedule during heavy rain season upon approval of the Landscape Architect.

AMOUNT OF WATER PER APPLICATION

- For trees up to 5 inch caliper - 5 gallons
- From 5 to 8 inch caliper - 25 gallons
- 9 inch and up caliper - 50 gallons

FREQUENCY OF WATER

- Daily for the first week
- 3 times per week for weeks 2 - 5
- 2 times per week for weeks 6 - 8
- 1 time per week for weeks 9 - 12

- B. Water in plants by thoroughly soaking of the entire root ball immediately after planting. For large trees and shrubs, add water while backfilling hole to eliminate any air pockets in the soil around the root ball.

- C. Water shrubs, sod and groundcover a minimum of once daily for a week or until an irrigation system is fully operational. If no irrigation system is to be installed, the Contractor shall be responsible for watering the shrub, sod, and groundcover for the time specified above, after installation of each section of the planting installed.

3.5 FERTILIZING

- A. Add fertilizer on top of the surface of shrubs beds and tree and palms root balls two (2) months after installation. Fertilize sod within two (2) days after installing after planting of each segment of the job. Fertilizer shall be applied after soil has been well moistened. Fertilizer shall be washed off of plant leaves and stems immediately after application. Apply at the following rates:

1. Trees and Large Shrubs: One (1) pound per inch of trunk diameter, spread evenly over the root ball area.
2. Shrubs: One half (1/2) handful per shrub, spread evenly over the root ball area.
3. Groundcover: Twelve (12) pounds per 100 sq. ft. of bed area.
4. Sod: Twelve (12) pounds per 1,000 sq. ft. Wash fertilizer off blades immediately after spreading.

3.6 MULCHING

- A. Spread mulch three (3) inches thick uniformly over the entire surface of shrubs and groundcover beds, depth measured after settling, unless otherwise specified in the plans. Provide 36" diameter bed of mulch, measured from outer edge of the trunk, for all trees and palms planted in sod areas. Keep mulch away from contact with the trunk. Create a 6" high ring of mulch at the outer edge of tree and palm holes.

3.7 GUYING AND BRACING

- A. See the details bound herewith or made part of the plans.

3.8 SODDING

- A. Provide a blanket of lawn sand as described in the notes in these plans. Prior to planting, remove stones, sticks, etc. from the sub-soil surface. Excavate existing non-conforming soil as required so that the finish grade of sod is flush with adjacent pavement or top of curb as well as adjacent sod in the case of sod patching.
- B. Place sod on moistened soil, with edges tightly butted, in staggered rows at right angles to slopes. The sod shall be rolled with a 500 pound hand roller immediately after placing.
- C. Keep edge of sod bed a minimum of 18" away from groundcover beds and 24" away from edge of shrub beds and 36" from trees, measured from the edge of plant or tree trunk.
- D. Sod shall be watered immediately after installation to uniformly wet the soil to at least two inches below the bottom of sod strips.
- E. Apply fertilizer to the sod as specified in Section 3.5.
- F. Excavate and remove excess soil so top of sod is flush w/top of curb or adjacent pavement, or adjacent existing sod.

PLANT BED PREPARATION NOTES

1. In all areas where new sod and shrub and groundcover masses are to be planted, kill all existing weeds by treating with systemic herbicide prior to beginning soil preparation.
2. In all shrub and groundcover beds, excavate and backfill soil as described in "Plant List(s)". If no specific preparation is noted, prepare soil as described below for either condition, over the entire area to be planted:

Condition A:

If any compacted road base or asphalt or rocky soil is encountered, remove compacted material entirely to allow an 18" depth of planting soil per plant list unless otherwise stated. Backfill the entire area of the shrub and groundcover beds with 18" planting soil (as specified in Plans) to within 2 inches of the adjacent pavement or top of curb. Remove all debris and rocks and pebbles larger than 2 inches in size and level the grade before planting.

Condition B:

Where no compacted soil is encountered, thoroughly mix 6 inches of planting soil per plant list into the existing soil to a depth of 18 inches unless otherwise stated. If required, excavate and remove the existing soil to lower the grade, so that the prepared mix is finished to a minimum of 2 inches below top of curb or adjacent walkway. Remove all debris and rocks and pebbles larger than 2 inches in size and level the grade before planting.

For all sod areas, spread a 2" deep layer of lawn sand prior to sodding. Remove all debris and rocks and pebbles larger than 2 inches in size and level the grade before sodding. Remove, if required, existing soil so that top of sod is flush with and adjacent top of curb or pavement.

For Trees and shrubs larger than 7 gallon, Add Diehard" transplant innoculant supplied by Horticultural Alliance, Inc. (800-628-6373) or equal. Mix into top 8-10 inches of planting hole, making sure it is contact with the root ball. Add at a rate specified by manufacturer (typically 4oz. per 1 inches of trunk caliper or 7 gallon can).

SPACING OF PLANTS (SEE PLANT SPACING DETAIL)

1. Plants shall be planted sufficiently away from edges of pavements or curbs, to allow for growth toward the edges of the bed.

PROTECTION OF PLANTS

1. The Contractor shall be responsible to protect existing trees and shrubs in and adjacent to the area of work. Erect barriers as necessary to keep equipment and materials, any toxic material, away from the canopy drip line of trees and shrubs. **DO NOT PILE SOIL OR DEBRIS AGAINST TREE TRUNKS OR DEPOSIT NOXIOUS BUILDING SUPPLIES OR CHEMICALS WITHIN THE DRIP LINE.**

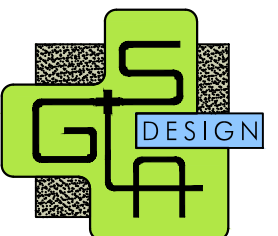

GARDNER + SEMLER
LANDSCAPE ARCHITECTURE
WWW.GSLADDESIGN.COM
17670 NW 78th AVE., SUITE 214
MIAMI, FL 33015
P 305.392.1016 F 305.392.1019
CORP. ID # 0000266

ARQUITECTONICA

2900 Oak Avenue, Miami, FL 33133
T 305.372.1812 F 305.372.1175

ALL DESIGNS INDICATED IN THESE DRAWINGS ARE PROPERTY OF ARQUITECTONICA INTERNATIONAL CORP. NO COPIES, TRANSMISSIONS, REPRODUCTIONS OR ELECTRONIC MANIPULATION OF ANY PORTION OF THESE DRAWINGS IN THE WHOLE OR IN PART ARE TO BE MADE WITHOUT THE EXPRESS WRITTEN AUTHORIZATION OF ARQUITECTONICA INTERNATIONAL CORP. DESIGN INTENT SHOWN IS SUBJECT TO REVIEW AND APPROVAL OF ALL APPLICABLE LOCAL AND GOVERNMENTAL AUTHORITIES HAVING JURISDICTION. ALL COPYRIGHTS RESERVED © 2021.
THE DATA INCLUDED IN THIS STUDY IS CONCEPTUAL IN NATURE AND WILL CONTINUE TO BE MODIFIED THROUGHOUT THE COURSE OF THE PROJECTS DEVELOPMENT WITH THE EVENTUAL INTEGRATION OF STRUCTURAL, MEP AND LIFE SAFETY SYSTEMS. AS THESE ARE FURTHER REFINED, THE NUMBERS WILL BE ADJUSTED ACCORDINGLY.

HPB FINAL SUBMITTAL
1509 - 1515 WASHINGTON AVE
MIAMI BEACH, FL 33139

Landscape Specifications



SCALE: 1" = 25'



DATE:
MAR 10, 2024

LA-107

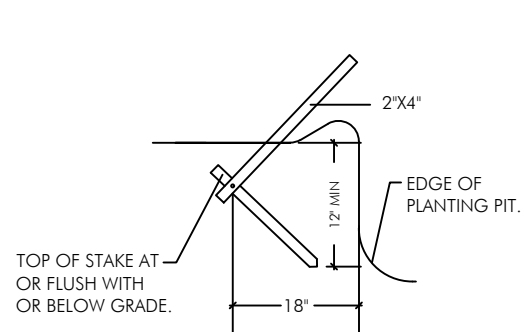

DETAIL A

N.T.S.

CURVED TRUNK LEAN ANGLE AS NOTED ON PLAN/PLANT LIST

NOTE - USE 4" X 4" STAKES PALMS OVER 12" CALIPER.

PROVIDE FOUR 2" X 4" PINE STAKES 90° APART (EXTRA STAKE IF NECESSARY TO SUPPORT LEAN). ATTACH W/NAILS TO BATTENS NO NAILS IN TREE.

SET ROOTBALL SO TRUNK FLARE OR TOP ROOT IS 2" ABOVE SURROUNDING GRADE.

INSTALL 3" OF MULCH OVER 3' DIAMETER CIRCLE AROUND THE TRUNK. DO NOT PLACE MULCH WITHIN 3" OF THE TRUNK.

REMOVE ANY PORTION OF WIRE BASKETS OR BURLAP ABOVE THE TOP HALF OF THE ROOTBALL. FOLD BACK BURLAP COVERINGS BELOW THE TOP HALF OF THE ROOTBALL. COMPLETELY REMOVE ALL SYNTHETIC ROOTBALL COVERING MATERIALS.

WOOD STAKES TOP OF STAKES BELOW OR FLUSH WITH GRADE.

ANGLE SUBGRADE BASE AND ROOTBALL IF NECESSARY TO ACHIEVE SPECIFIED LEAN ANGLE.

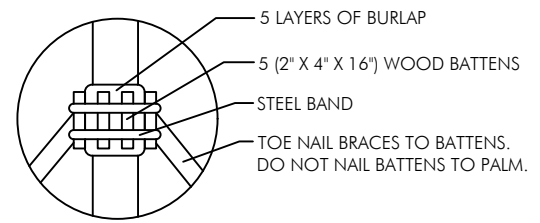
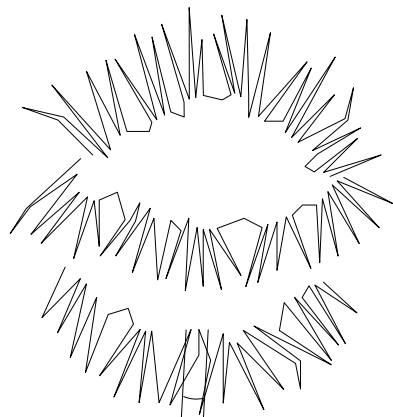

BATTEN DETAIL B

N.T.S.

NOTE - SECURE BATTENS WITH 2-3/4" HI CARBON STEEL BANDS TO HOLD BATTENS IN PLACE DURING PLANTING PROCESS. DO NOT NAIL BATTENS TO PALM. THE HEIGHT OF THE BATTENS SHALL BE LOCATED IN RELATION TO THE HEIGHT OF THE PALM FOR ADEQUATE BRACING. PAINT ALL EXPOSED WOOD SURFACES, (COLOR TO BE APPROVED BY LANDSCAPE ARCHITECT).

ALL SUPPORT MATERIALS ARE TO BE REMOVED FROM THE PALMS ONCE THE TREES HAVE BECOME ESTABLISHED (NOT TO EXCEED 12 MONTHS FROM THE COMPLETION OF THE PROJECT).

6" HIGH TEMPORARY RETENTION RING OF SOIL TO ASSIST IN IRRIGATION OF THE TREE. REMOVE RING 3 MONTHS AFTER INSTALLATION.

FINISHED GRADE

HOLES TO ACCOMMODATE PLANTS SHALL BE A MINIMUM OF THREE TIMES THE SIZED OF THE PLANT ROOTBALL.

ALL BACKFILL FOR TREES SHALL BE PLANTING SOIL

FERTILIZER SHALL BE INSTALLED AS PER THE WRITTEN SPECIFICATIONS.

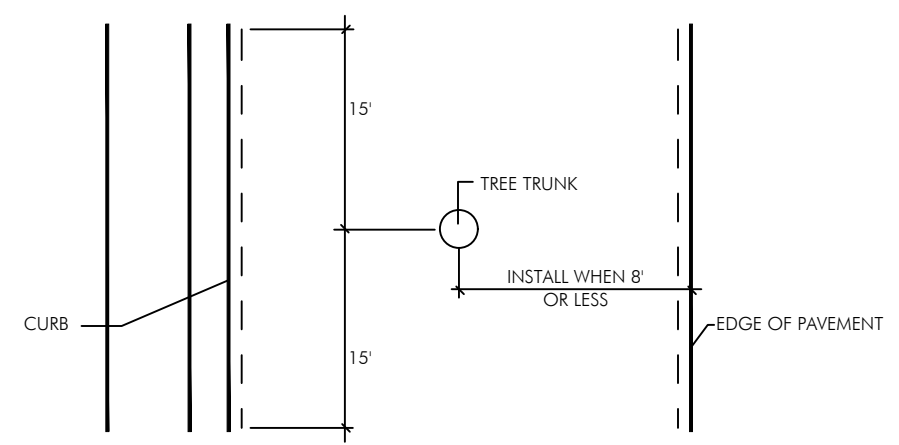

PLAN VIEW

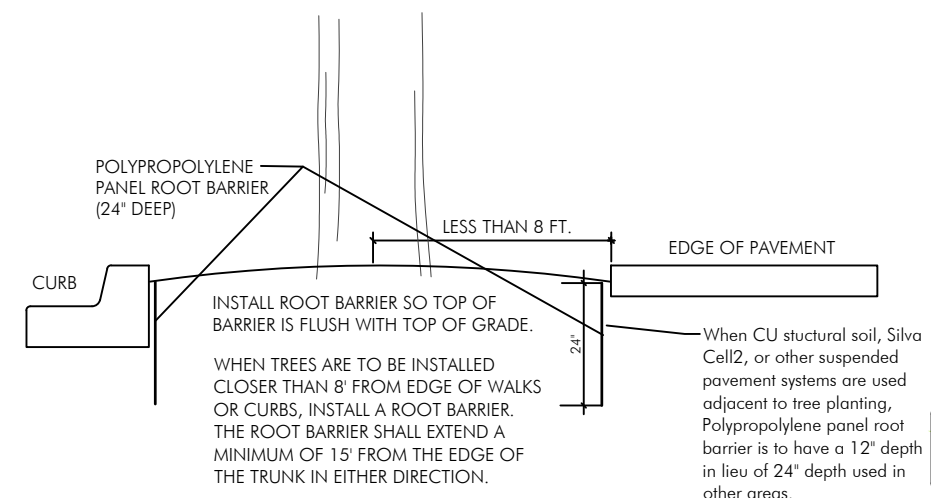

ROOT BARRIER INSTALLATION DETAIL

N.T.S.

PLANTING & BRACING DETAIL FOR LEANING/CROOKED PALMS

N.T.S.



GARDNER + SEMLER
LANDSCAPE ARCHITECTURE
WWW.GSLADDESIGN.COM
17670 NW 78th AVE., SUITE 214
MIAMI, FL 33015
P 305.392.1016 F 305.392.1019
CORP. 1 D # 0 0 0 2 6 6

ARQUITECTONICA

2900 Oak Avenue, Miami, FL 33133
T 305.372.1812 F 305.372.1175

ALL DESIGNS INDICATED IN THESE DRAWINGS ARE PROPERTY OF ARQUITECTONICA INTERNATIONAL CORP. NO COPIES, TRANSMISSIONS, REPRODUCTIONS OR ELECTRONIC MANIPULATION OF ANY PORTION OF THESE DRAWINGS IN THE WHOLE OR IN PART ARE TO BE MADE WITHOUT THE EXPRESS WRITTEN AUTHORIZATION OF ARQUITECTONICA INTERNATIONAL CORP. DESIGN INTENT SHOWN IS SUBJECT TO REVIEW AND APPROVAL OF ALL APPLICABLE LOCAL AND GOVERNMENTAL AUTHORITIES HAVING JURISDICTION. ALL COPYRIGHTS RESERVED © 2021.
THE DATA INCLUDED IN THIS STUDY IS CONCEPTUAL IN NATURE AND WILL CONTINUE TO BE MODIFIED THROUGHOUT THE COURSE OF THE PROJECTS DEVELOPMENT WITH THE EVENTUAL INTEGRATION OF STRUCTURAL, MEP AND LIFE SAFETY SYSTEMS. AS THESE ARE FURTHER REFINED, THE NUMBERS WILL BE ADJUSTED ACCORDINGLY.

HPB FINAL SUBMITTAL
1509 - 1515 WASHINGTON AVE
MIAMI BEACH, FL 33139

Planting Details

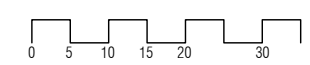

SCALE: 1" = 25'



DATE:
MAR 10, 2024

LA-108

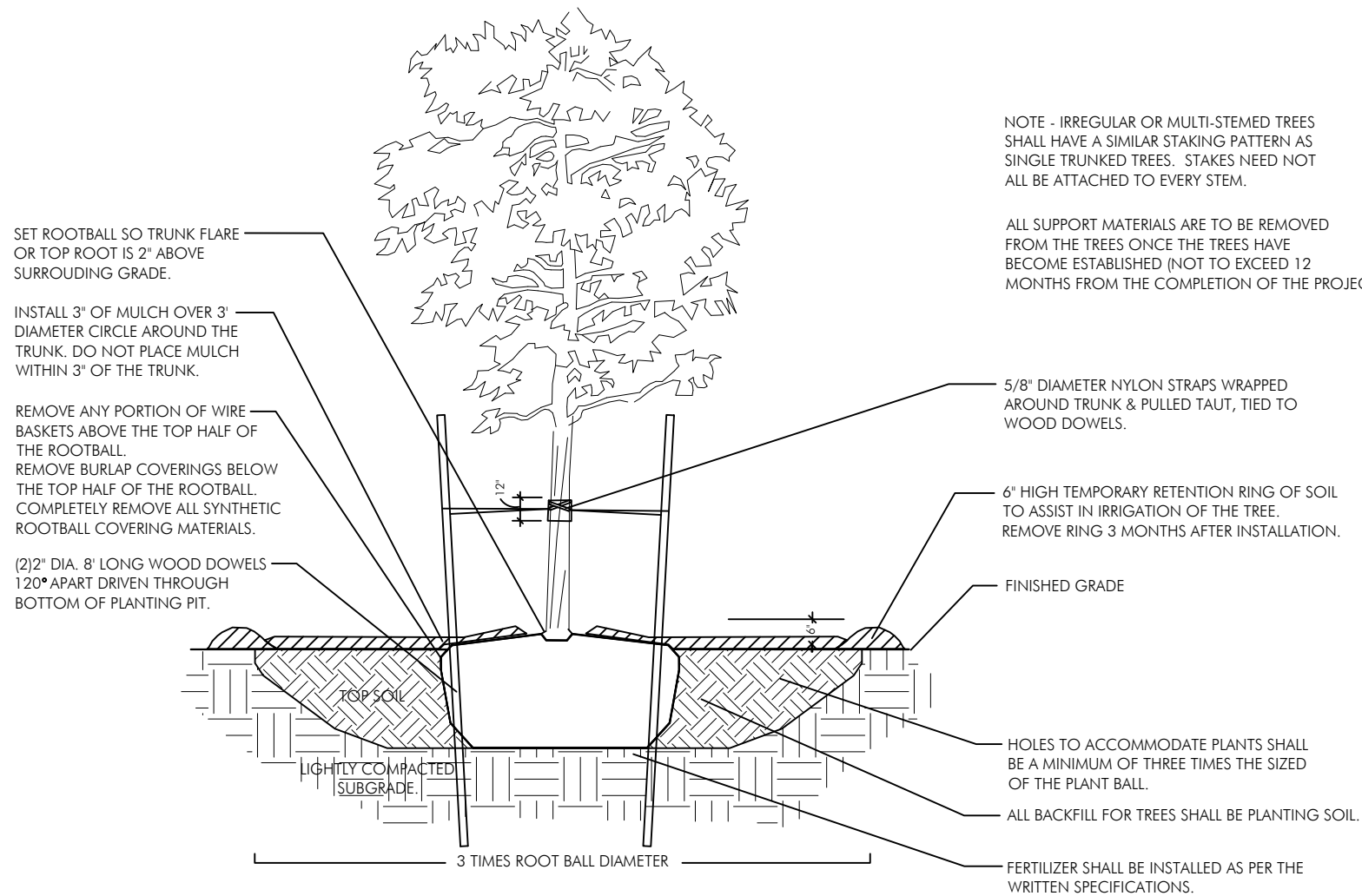

PLANTING & BRACING DETAIL UNDER 3 1/2" CALIPER

N.T.S.

NOTE - IRREGULAR OR MULTI-STEMED TREES SHALL HAVE A SIMILAR STAKING PATTERN AS SINGLE TRUNKED TREES. STAKES NEED NOT ALL BE ATTACHED TO EVERY STEM.

ALL SUPPORT MATERIALS ARE TO BE REMOVED FROM THE TREES ONCE THE TREES HAVE BECOME ESTABLISHED (NOT TO EXCEED 12 MONTHS FROM THE COMPLETION OF THE PROJECT).

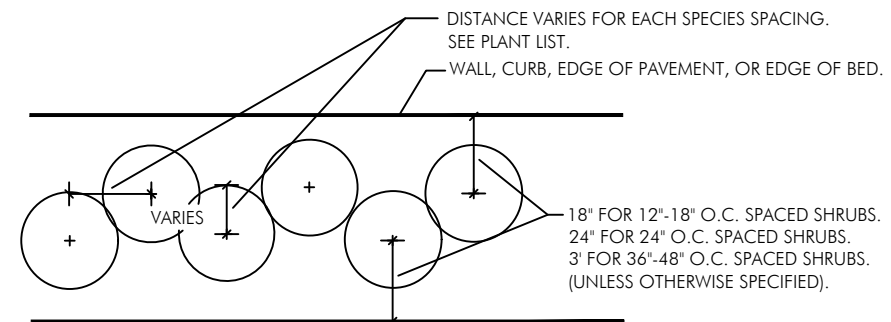

SHRUB SPACING DIAGRAM

N.T.S.

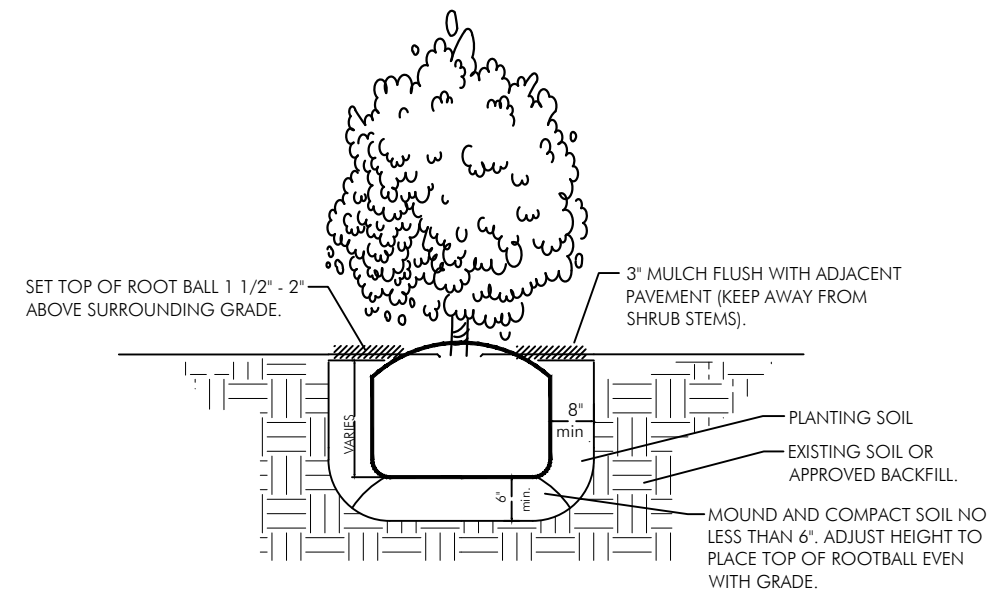

SHRUB INSTALLATION DETAIL

N.T.S.



GARDNER + SEMLER
LANDSCAPE ARCHITECTURE
WWW.GSLDESIGN.COM
17670 NW 78th AVE., SUITE 214
MIAMI, FL 33015
P 305.392.1016 F 305.392.1019
CORP. 1 D # 0000266

ARQUITECTONICA

2900 Oak Avenue, Miami, FL 33133
T 305.372.1812 F 305.372.1175

ALL DESIGNS INDICATED IN THESE DRAWINGS ARE PROPERTY OF ARQUITECTONICA INTERNATIONAL CORP. NO COPIES, TRANSMISSIONS, REPRODUCTIONS OR ELECTRONIC MANIPULATION OF ANY PORTION OF THESE DRAWINGS IN THE WHOLE OR IN PART ARE TO BE MADE WITHOUT THE EXPRESS WRITTEN AUTHORIZATION OF ARQUITECTONICA INTERNATIONAL CORP. DESIGN INTENT SHOWN IS SUBJECT TO REVIEW AND APPROVAL OF ALL APPLICABLE LOCAL AND GOVERNMENTAL AUTHORITIES HAVING JURISDICTION. ALL COPYRIGHTS RESERVED © 2021.
THE DATA INCLUDED IN THIS STUDY IS CONCEPTUAL IN NATURE AND WILL CONTINUE TO BE MODIFIED THROUGHOUT THE COURSE OF THE PROJECTS DEVELOPMENT WITH THE EVENTUAL INTEGRATION OF STRUCTURAL, MEP AND LIFE SAFETY SYSTEMS. AS THESE ARE FURTHER REFINED, THE NUMBERS WILL BE ADJUSTED ACCORDINGLY.

HPB FINAL SUBMITTAL
1509 - 1515 WASHINGTON AVE
MIAMI BEACH, FL 33139

Planting Details



SCALE: 1" = 25'



DATE:
MAR 10, 2024

LA-109

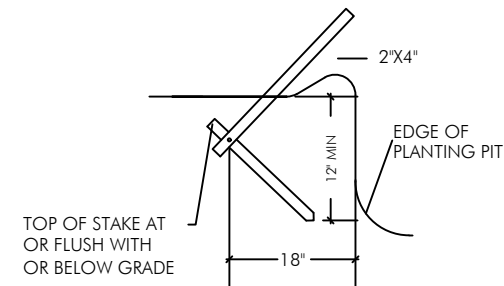

DETAIL A

N.T.S.

NOTE - USE 4" X 4" STAKES PALMS OVER 12" CALIPER.

PROVIDE FOUR 2' X 4' PINE STAKES 120° APART. ATTACH W/NAILS TO BATTENS. NO NAILS IN TREE.

SET ROOTBALL SO TRUNK FLARE OR TOP ROOT IS 2" ABOVE SURROUNDING GRADE.

INSTALL 3" OF MULCH OVER 3' DIAMETER CIRCLE AROUND THE TRUNK. DO NOT PLACE MULCH WITHIN 3" OF THE TRUNK.

REMOVE ANY PORTION OF WIRE BASKETS OR BURLAP ABOVE THE TOP HALF OF THE ROOTBALL. FOLD BACK BURLAP COVERINGS BELOW THE TOP HALF OF THE ROOTBALL. COMPLETELY REMOVE ALL SYNTHETIC ROOTBALL COVERING MATERIALS.

WOOD STAKES TOP OF STAKES BELOW OR FLUSH WITH GRADE.

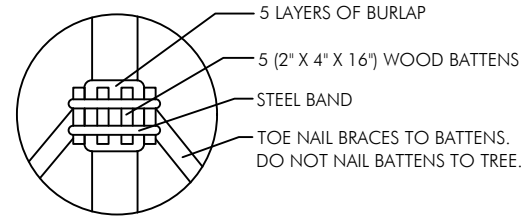
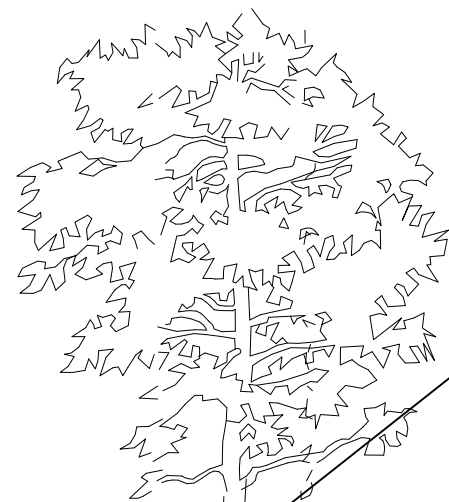

BATTEN DETAIL B

N.T.S.

NOTE - SECURE BATTENS WITH 2-3/4" HI CARBON STEEL BANDS TO HOLD BATTENS IN PLACE DURING PLANTING PROCESS. DO NOT NAIL BATTENS TO TREE. THE HEIGHT OF THE BATTENS SHALL BE LOCATED IN RELATION TO THE HEIGHT OF THE TREE FOR ADEQUATE BRACING. PAINT ALL EXPOSED WOOD SURFACES, (COLOR TO BE APPROVED BY LANDSCAPE ARCHITECT).

NOTE - IRREGULAR OR MULTI-STEMED TREES SHALL HAVE A SIMILAR STAKING PATTERN AS SINGLE TRUNKED TREES. STAKES NEED NOT ALL BE ATTACHED TO EVERY STEM.

ALL SUPPORT MATERIALS ARE TO BE REMOVED FROM THE TREES ONCE THE TREES HAVE BECOME ESTABLISHED (NOT TO EXCEED 12 MONTHS FROM THE COMPLETION OF THE PROJECT).

PLANTING & BRACING DETAIL OVER 3 1/2" CALIPER

N.T.S.

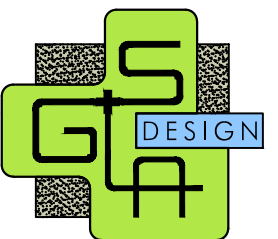

GARDNER + SEMLER
LANDSCAPE ARCHITECTURE
WWW.GSLADDESIGN.COM
17670 NW 78th AVE., SUITE 214
MIAMI, FL 33015
P 305.392.1016 F 305.392.1019
CORP. ID # 0000266

ARQUITECTONICA

2900 Oak Avenue, Miami, FL 33133
T 305.372.1812 F 305.372.1175

ALL DESIGNS INDICATED IN THESE DRAWINGS ARE PROPERTY OF ARQUITECTONICA INTERNATIONAL CORP. NO COPIES, TRANSMISSIONS, REPRODUCTIONS OR ELECTRONIC MANIPULATION OF ANY PORTION OF THESE DRAWINGS IN THE WHOLE OR IN PART ARE TO BE MADE WITHOUT THE EXPRESS WRITTEN AUTHORIZATION OF ARQUITECTONICA INTERNATIONAL CORP. DESIGN INTENT SHOWN IS SUBJECT TO REVIEW AND APPROVAL OF ALL APPLICABLE LOCAL AND GOVERNMENTAL AUTHORITIES HAVING JURISDICTION. ALL COPYRIGHTS RESERVED © 2021. THE DATA INCLUDED IN THIS STUDY IS CONCEPTUAL IN NATURE AND WILL CONTINUE TO BE MODIFIED THROUGHOUT THE COURSE OF THE PROJECTS DEVELOPMENT WITH THE EVENTUAL INTEGRATION OF STRUCTURAL, MEP AND LIFE SAFETY SYSTEMS. AS THESE ARE FURTHER REFINED, THE NUMBERS WILL BE ADJUSTED ACCORDINGLY.

HPB FINAL SUBMITTAL
1509 - 1515 WASHINGTON AVE
MIAMI BEACH, FL 33139

Planting Details



SCALE: 1" = 25'



DATE:
MAR 10, 2024

LA-110

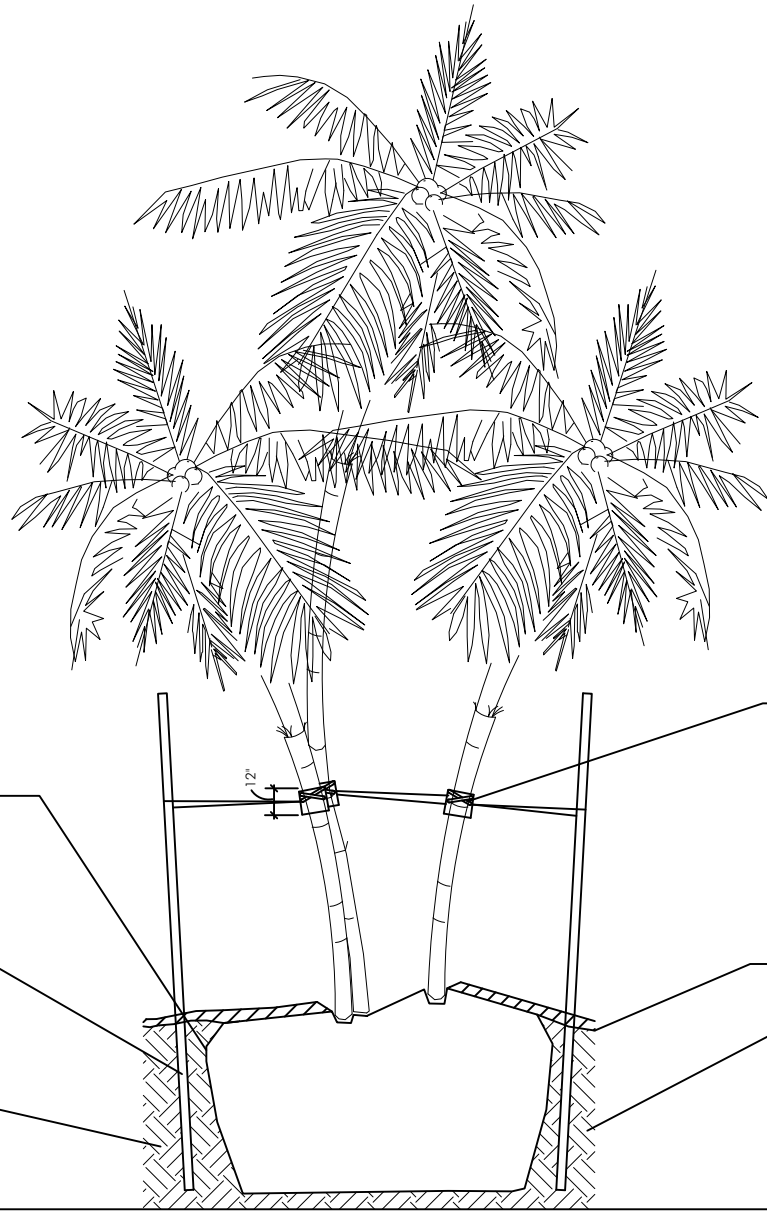

NOTE - IRREGULAR OR MULTI-STEMED TREES SHALL HAVE A SIMILAR STAKING PATTERN AS SINGLE TRUNKED TREES. STAKES NEED NOT ALL BE ATTACHED TO EVERY STEM.

ALL SUPPORT MATERIALS ARE TO BE REMOVED FROM THE TREES ONCE THE TREES HAVE BECOME ESTABLISHED (NOT TO EXCEED 12 MONTHS FROM THE COMPLETION OF THE PROJECT).

REMOVE ANY PORTION OF WIRE BASKETS ABOVE THE TOP HALF OF THE ROOTBALL. REMOVE BURLAP COVERINGS BELOW THE TOP HALF OF THE ROOTBALL. COMPLETE REMOVE ALL SYNTHETIC ROOTBALL COVERING MATERIALS.

(4) 2" DIA. 8' LONG WOOD DOWELS AT CORNERS DRIVEN TO BOTTOM OF PLANTER.

PLANTING SOIL

5/8" DIAMETER NYLON STRAPS WRAPPED AROUND TRUNK & PULLED TAUT, TIED TO WOOD DOWELS.

WALKWAY OR HARDSCAPE AREA.

FINISHED GRADE

PLANTING SOIL

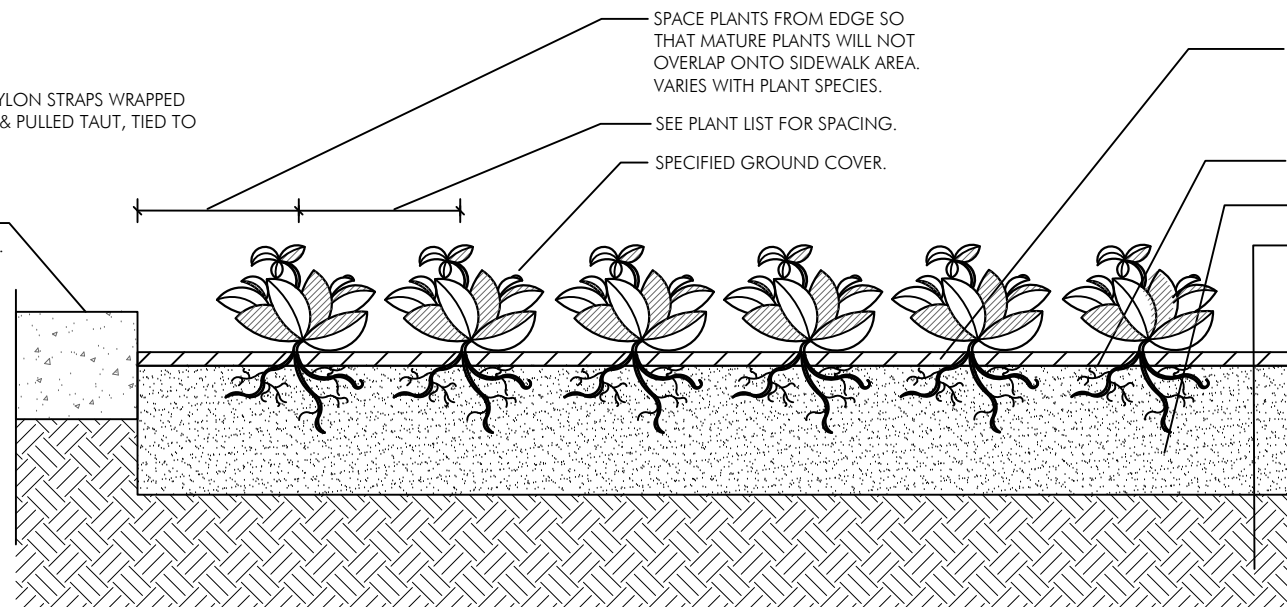

SPACE PLANTS FROM EDGE SO THAT MATURE PLANTS WILL NOT OVERLAP ONTO SIDEWALK AREA. VARIES WITH PLANT SPECIES.

SEE PLANT LIST FOR SPACING.

SPECIFIED GROUND COVER.

3" PINE MULCH (NO CYPRESS, NO RED). TOP OF MULCH SHALL BE 2" BELOW PAVEMENT.

FINISHED GRADE

SPECIFIED PLANTING MIXTURE.

EXISTING SOIL OR APPROVED BACKFILL.

MULTI-TRUNKED TREE/PALM BRACING DETAIL

N.T.S.

GROUND COVER PLANTING DETAIL

N.T.S.



GARDNER + SEMLER
LANDSCAPE ARCHITECTURE
WWW.GSLADESIGN.COM
17670 NW 78th AVE., SUITE 214
MIAMI, FL 33015
P 305.392.1016 F 305.392.1019
CORP. ID # 0000266

ARQUITECTONICA

2900 Oak Avenue, Miami, FL 33133
T 305.372.1812 F 305.372.1175

ALL DESIGNS INDICATED IN THESE DRAWINGS ARE PROPERTY OF ARQUITECTONICA INTERNATIONAL CORP. NO COPIES, TRANSMISSIONS, REPRODUCTIONS OR ELECTRONIC MANIPULATION OF ANY PORTION OF THESE DRAWINGS IN THE WHOLE OR IN PART ARE TO BE MADE WITHOUT THE EXPRESS WRITTEN AUTHORIZATION OF ARQUITECTONICA INTERNATIONAL CORP. DESIGN INTENT SHOWN IS SUBJECT TO REVIEW AND APPROVAL OF ALL APPLICABLE LOCAL AND GOVERNMENTAL AUTHORITIES HAVING JURISDICTION. ALL COPYRIGHTS RESERVED © 2021.
THE DATA INCLUDED IN THIS STUDY IS CONCEPTUAL IN NATURE AND WILL CONTINUE TO BE MODIFIED THROUGHOUT THE COURSE OF THE PROJECTS DEVELOPMENT WITH THE EVENTUAL INTEGRATION OF STRUCTURAL, MEP AND LIFE SAFETY SYSTEMS. AS THESE ARE FURTHER REFINED, THE NUMBERS WILL BE ADJUSTED ACCORDINGLY.

HPB FINAL SUBMITTAL
1509 - 1515 WASHINGTON AVE
MIAMI BEACH, FL 33139

Planting Details



SCALE: 1" = 25'



DATE:
MAR 10, 2024

LA-111

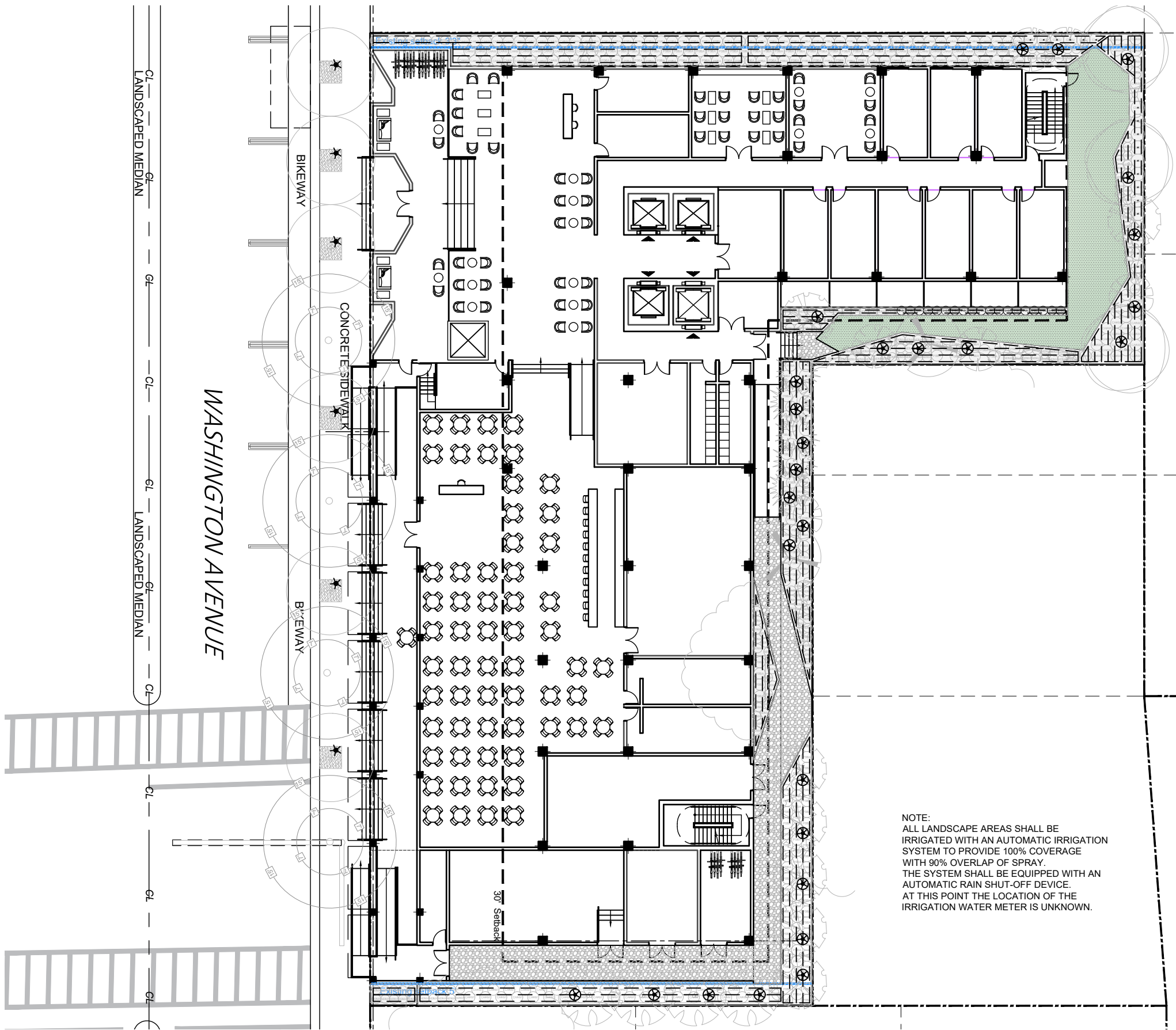

IRRIGATION MATERIALS LIST

KEY	ITEM	QTY.
—	PVC laterals shall be Class 200 PVC (sized as shown on plans)	as required
—	MAIN shall be Class 200 PVC	as required
- - -	Bubbler Zone Piping	as required
≡	PVC sleeves shall be Class 200 PVC (sized double the width of the pipe within, installed wherever pipe runs under hardscape)	as required
	Flexible PVC or Polypipe (for swing joints)	as required
WM	Water Meter and Backflow Prevention Assembly (See Civil Plans)	1
EC	Electric Controller RAINBIRD ___ Series Controller	1
▲	Rainbird RSD Series Rain Sensor (locate in area of free rainfall)	1
●	RAINBIRD 200-PESB 2" Electromechanical Solenoid Control Valve	#
	Irrigation Control Wire	as required
★	RAINBIRD 1300A-F Adjustable Flood Bubbler 1300A-F (1.5 gpm)	as required
▼	Rainbird 1" Inline Pressure Regulator (PSI-M40X-100)(drip zones not to exceed 40psi max)	as required
- - -	RAINBIRD XFS Subsurface Dripline XFS-09-12-500/250/100 Air/Vacuum Relief Valves Kit (3/4" Air relief valve/ Easy Fit Compression Tee/ and Flush Cap)	as required
■	Residential ___ Flow Control Zone Kit (___) (# gpm) (___ Valve w/ ___ Filter)	1
✂	RAINBIRD 3-RC Quick Coupler Valve	1
≡	PVC Supply Header for dripline Class 200 PVC	as required
⊗	RAINBIRD Xeri-Bubbler UXB-360-1032 (.6 gpm)	#
▲	RAINBIRD Xeri-Spray Adjustable mister 360 ADJMST (.1 gpm) (install into dripline with Xeri-bug drip emitters for spray into bromeliad cups)	#

LATERAL PIPE SIZING
 The Contractor is responsible to properly size all laterals. All laterals shall be sized according to the following schedule. Total gallonage per pipe section shall be calculated by adding the GPM per head for every head downstream of the pipe.

NOTE:
 ALL LANDSCAPE AREAS SHALL BE IRRIGATED WITH AN AUTOMATIC IRRIGATION SYSTEM TO PROVIDE 100% COVERAGE WITH 90% OVERLAP OF SPRAY. THE SYSTEM SHALL BE EQUIPPED WITH AN AUTOMATIC RAIN SHUT-OFF DEVICE. AT THIS POINT THE LOCATION OF THE IRRIGATION WATER METER IS UNKNOWN.

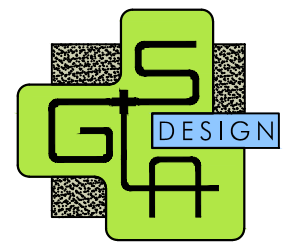

GARDNER + SEMLER
 LANDSCAPE ARCHITECTURE
 WWW.GSLADESIGN.COM
 17670 NW 78th AVE., SUITE 214
 MIAMI, FL 33015
 P 305.392.1016 F 305.392.1019
 CORP. 1 D # 0 0 0 2 6 6

ARQUITECTONICA
 2900 Oak Avenue, Miami, FL 33133
 T 305.372.1812 F 305.372.1175

ALL DESIGNS INDICATED IN THESE DRAWINGS ARE PROPERTY OF ARQUITECTONICA INTERNATIONAL CORP. NO COPIES, TRANSMISSIONS, REPRODUCTIONS OR ELECTRONIC MANIPULATION OF ANY PORTION OF THESE DRAWINGS IN THE WHOLE OR IN PART ARE TO BE MADE WITHOUT THE EXPRESS WRITTEN AUTHORIZATION OF ARQUITECTONICA INTERNATIONAL CORP. DESIGN INTENT SHOWN IS SUBJECT TO REVIEW AND APPROVAL OF ALL APPLICABLE LOCAL AND GOVERNMENTAL AUTHORITIES HAVING JURISDICTION. ALL COPYRIGHTS RESERVED © 2021. THE DATA INCLUDED IN THIS STUDY IS CONCEPTUAL IN NATURE AND WILL CONTINUE TO BE MODIFIED THROUGHOUT THE COURSE OF THE PROJECTS DEVELOPMENT WITH THE EVENTUAL INTEGRATION OF STRUCTURAL, MEP AND LIFE SAFETY SYSTEMS. AS THESE ARE FURTHER REFINED, THE NUMBERS WILL BE ADJUSTED ACCORDINGLY.

HPB FINAL SUBMITTAL
 1509 - 1515 WASHINGTON AVE
 MIAMI BEACH, FL 33139

Ground Floor Irrigation Plan

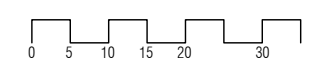

SCALE: 1" = 25'

DATE: **MAR 10, 2024** **LA-112**

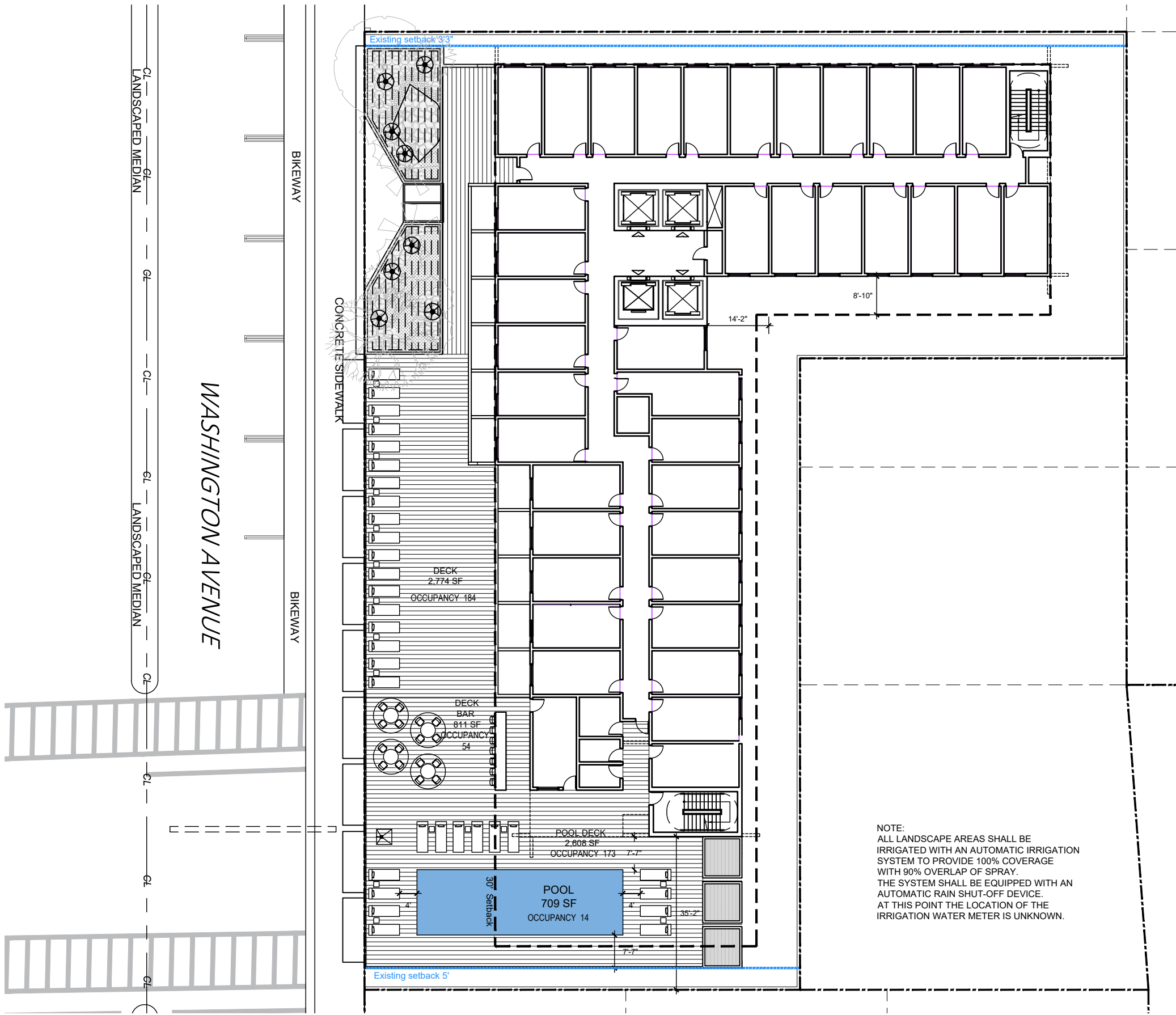

NOTE:
ALL LANDSCAPE AREAS SHALL BE IRRIGATED WITH AN AUTOMATIC IRRIGATION SYSTEM TO PROVIDE 100% COVERAGE WITH 90% OVERLAP OF SPRAY. THE SYSTEM SHALL BE EQUIPPED WITH AN AUTOMATIC RAIN SHUT-OFF DEVICE. AT THIS POINT THE LOCATION OF THE IRRIGATION WATER METER IS UNKNOWN.

IRRIGATION MATERIALS LIST

KEY	ITEM	QTY.
—	PVC laterals shall be Class 200 PVC (sized as shown on plans)	as required
—	MAIN shall be Class 200 PVC	as required
WM	Water Meter and Backflow Prevention Assembly (See Civil Plans)	1
EC	Electric Controller RAINBIRD ___ Series Controller	1
▲	Rainbird RSD Series Rain Sensor (locate in area of free rainfall)	1
⊕	RAINBIRD 200-PESB 2" Electromechanical Solenoid Control Valve	#
—	Irrigation Control Wire	as required
▼	Rainbird 1" Inline Pressure Regulator (PSI-M40X-100)(drip zones not to exceed 40psi max)	as required
---	RAINBIRD XFS Subsurface Dripperline XFS-09-12-500/250/100 Air/Vacuum Relief Valves Kit (3/4" Air relief valve/ Easy Fit Compression Tee/ and Flush Cap)	as required
■	Residential ___ Flow Control Zone Kit (___) (___ gpm) (___ Valve w/ ___ Filter)	1
✕	RAINBIRD 3-RC Quick Coupler Valve	1
≡	PVC Supply Header for dripperline Class 200 PVC	as required
⊗	RAINBIRD Xeri-Bubbler UXB-360-1032 (.6 gpm)	#
▲	RAINBIRD Xeri-Spray Adjustable mister 360 ADJMST (.1 gpm) (install into dripline with Xeri-bug drip emitters for spray into bromeliad cups)	#

LATERAL PIPE SIZING
The Contractor is responsible to properly size all laterals. All laterals shall be sized according to the following schedule. Total gallonage per pipe section shall be calculated by adding the GPM per head for every head downstream of the pipe.



GARDNER + SEMLER
LANDSCAPE ARCHITECTURE
WWW.GSLDESIGN.COM
17670 NW 78th AVE., SUITE 214
MIAMI, FL 33015
P 305.392.1016 F 305.392.1019
CORP. 1 D # 0 0 0 0 2 6 6

ARQUITECTONICA

2900 Oak Avenue, Miami, FL 33133
T 305.372.1812 F 305.372.1175

ALL DESIGNS INDICATED IN THESE DRAWINGS ARE PROPERTY OF ARQUITECTONICA INTERNATIONAL CORP. NO COPIES, TRANSMISSIONS, REPRODUCTIONS OR ELECTRONIC MANIPULATION OF ANY PORTION OF THESE DRAWINGS IN THE WHOLE OR IN PART ARE TO BE MADE WITHOUT THE EXPRESS WRITTEN AUTHORIZATION OF ARQUITECTONICA INTERNATIONAL CORP. DESIGN INTENT SHOWN IS SUBJECT TO REVIEW AND APPROVAL OF ALL APPLICABLE LOCAL AND GOVERNMENTAL AUTHORITIES HAVING JURISDICTION. ALL COPYRIGHTS RESERVED © 2021.
THE DATA INCLUDED IN THIS STUDY IS CONCEPTUAL IN NATURE AND WILL CONTINUE TO BE MODIFIED THROUGHOUT THE COURSE OF THE PROJECTS DEVELOPMENT WITH THE EVENTUAL INTEGRATION OF STRUCTURAL, MEP AND LIFE SAFETY SYSTEMS. AS THESE ARE FURTHER REFINED, THE NUMBERS WILL BE ADJUSTED ACCORDINGLY.

HPB FINAL SUBMITTAL
1509 - 1515 WASHINGTON AVE
MIAMI BEACH, FL 33139

Second Floor Irrigation Plan

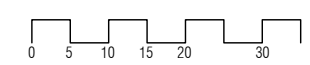

SCALE: 1" = 25'



DATE:
MAR 10, 2024

LA-113

GENERAL NOTES:

- 1. **SCOPE OF WORK:** The Contractor shall furnish all labor, machinery, tools, supplies, and equipment as necessary to construct and provide an operating system, as indicated in the Plans. The work shall include, but not be limited to, furnishing materials (pipe, valves, sprinkler heads, fittings, controllers, electrical, wire and fittings, primer, glue, etc.), layout, protection to the public, excavation, assembly, installation, backfilling, compaction, repair of road or pavement surfaces, controller and low voltage feed to the valves, clean-up, maintenance and guarantee, and as-built plans.
- 2. Contractor shall coordinate with General Contractor or other pertinent Contractors on the job to insure that sleeves are provided and installed under hard surfaces to allow access to all areas to be irrigated. All sleeves shall be constructed of Class 200 PVC. Bury all sleeves a minimum of 18" below the surface. Sleeve to be double the size if the pipe running through it. Sleeve shall extend 24" past the edge of pavement into the area to be irrigated.
- 3. **GUARANTEE:** The irrigation system shall be guaranteed for a minimum of one calendar year from the time of final acceptance.
- 4. **REPAIR UTILITIES:** The Contractor shall be responsible to verify the location of all utilities by hand excavation or other appropriate measures before performing any work that may result in damage to utilities structures, or property. The Contractor shall take immediate steps to repair, replace, or restore all services to any utilities which are disrupted due to his operations. All costs involved in disruption of service and repairs due to negligence on part of the Contractor shall be his responsibility.
- 5. **AS-BUILT DRAWINGS:** Prints of the plans will be supplied to the Contractor for recording "as-built" information. Immediately upon installation of any work which deviates from what is shown on the Plans, the Contractor shall clearly indicate such changes in red pencil on the prints. Such changes shall include, but not be limited to, changes in (1) materials; (2) sizes of material; (3) location; and (4) quantities.
- 6. The entire installation shall fully comply with all applicable local and state codes and ordinances. The Contractor shall take out all required plumbing and electrical applications and permits, arrange for all necessary inspections and shall pay all fees and expenses in connection with same as part of work under the contract.
- 7. **UNIT PRICES:** The successful bidder shall furnish, to the Owner, a unit price breakdown for all materials. The Owner may at his own discretion, add to or delete from the materials, using the unit price breakdown submitted to and accepted by the Owner.
- 8. **MAINTENANCE PERIOD:** The irrigation system shall be maintained for a period of 90 days after final acceptance of installation. Maintenance shall include checking of the system 2 times per week. Contractor shall be responsible to replace/repair any broken or malfunctioning parts of the system including those damaged by accidents or vandalism. Repairs shall be made immediately at the time of inspection or when notified by the Landscape Architect.
- 9. The irrigation system shall provide 100% coverage with a minimum of 90% overlap of water spray.
- 10. The system is design to provide sprinkler precipitation rates that are nearly equal in each zone. Mixing of sprinklers with widely varying precipitation rates in a zone will not be accepted.
- 11. Irrigation mainline shall be made of Class 200 PVC and all laterals shall be Class 200 PVC, except flexible PVC (or Toro funny pipe) for flexible swing joint and Schedule 40 PVC risers for spray heads in shrub areas. Schedule 80 galvanized steel pipe is to be used for all above ground fittings. Pipe locations shall be adjusted in the field. When laying out mains and laterals, locate pipe near edges of pavement or against buildings wherever possible, to allow space for plant rootballs. Coordinate pipe locations with plantings. Bury all mains and laterals 18" min. below surface. Depth shall be measured to top of pipe.
- 12. Keep pop-up sprinkler heads a minimum of 8" from edges of pavement and curbing, and heads on risers a minimum of 18", or as indicated in the pans.
- 13. All heads located in shrub or groundcover beds shall be installed on a riser as per details in the plans. All other heads shall be installed on a swing joint as per details in the plans.

14. Place irrigation control wire in conduit in the same trench as mains and under the main. ASI wire shall be #14 or larger solid copper U.L. approved underground direct burial cable and shall be continuous with no splices from controller to solenoid valve.

15. Valve locations are schematic and shall be adjusted in the field. Each valve shall be in a separate valve box (10" x 16" min.). When grouping valve boxes in grass or groundcover areas, set boxes a minimum of 12" apart to allow grass or groundcover to grow between them. When possible, hide valve boxes in shrub beds, a minimum of 12" from edge of beds. Set all valve boxes, concrete or plastic, in ground with cover flush with finish grade, and level, with a minimum of 6" of pea gravel at the bottom of the box, with at least 2" of clearance from the bottom of the valve to the top of the gravel.

16. **TESTING:** Notify the Landscape Architect in writing when testing will be conducted. Conduct test in the presence of the Landscape Architect. After all PVC assembly is completed the lines shall be flushed to insure that no rocks, sand, or other foreign debris remains in the lines. The mains shall be filled with water and all outlets shall be capped and plugged. The main shall be pressurized to 100 PSI for a minimum of one hour. No section of the main will be approved if the pressure drops more than 5 PSI at the end of the one hour period. Leaks shall be repaired immediately and the system shall be re-tested until found satisfactory by the Landscape Architect.

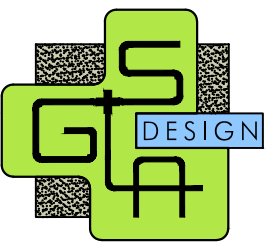

GARDNER + SEMLER
LANDSCAPE ARCHITECTURE
WWW.GSLDESIGN.COM
17670 NW 78th AVE., SUITE 214
MIAMI, FL 33015
P 305.392.1016 F 305.392.1019
CORP. ID # 0000266

ARQUITECTONICA

2900 Oak Avenue, Miami, FL 33133
T 305.372.1812 F 305.372.1175

ALL DESIGNS INDICATED IN THESE DRAWINGS ARE PROPERTY OF ARQUITECTONICA INTERNATIONAL CORP. NO COPIES, TRANSMISSIONS, REPRODUCTIONS OR ELECTRONIC MANIPULATION OF ANY PORTION OF THESE DRAWINGS IN THE WHOLE OR IN PART ARE TO BE MADE WITHOUT THE EXPRESS WRITTEN AUTHORIZATION OF ARQUITECTONICA INTERNATIONAL CORP. DESIGN INTENT SHOWN IS SUBJECT TO REVIEW AND APPROVAL OF ALL APPLICABLE LOCAL AND GOVERNMENTAL AUTHORITIES HAVING JURISDICTION. ALL COPYRIGHTS RESERVED © 2021. THE DATA INCLUDED IN THIS STUDY IS CONCEPTUAL IN NATURE AND WILL CONTINUE TO BE MODIFIED THROUGHOUT THE COURSE OF THE PROJECTS DEVELOPMENT WITH THE EVENTUAL INTEGRATION OF STRUCTURAL, MEP AND LIFE SAFETY SYSTEMS. AS THESE ARE FURTHER REFINED, THE NUMBERS WILL BE ADJUSTED ACCORDINGLY.

HPB FINAL SUBMITTAL
1509 - 1515 WASHINGTON AVE
MIAMI BEACH, FL 33139

Irrigation Specifications



SCALE: 1" = 25'



DATE:
MAR 10, 2024

LA-114

NOTE:
 ALL WIRE CONNECTIONS SHALL BE APPROVED WATERTIGHT CONNECTIONS.
 FINISH ENTIRE ASSEMBLY, EXCEPT FOR EQUIPMENT, WITH FLAT BLACK ACRYLIC ENAMEL PAINT.
 PRIME METALLIC SURFACES WITH ZINC CHROMATE PRIOR TO FINISHING.

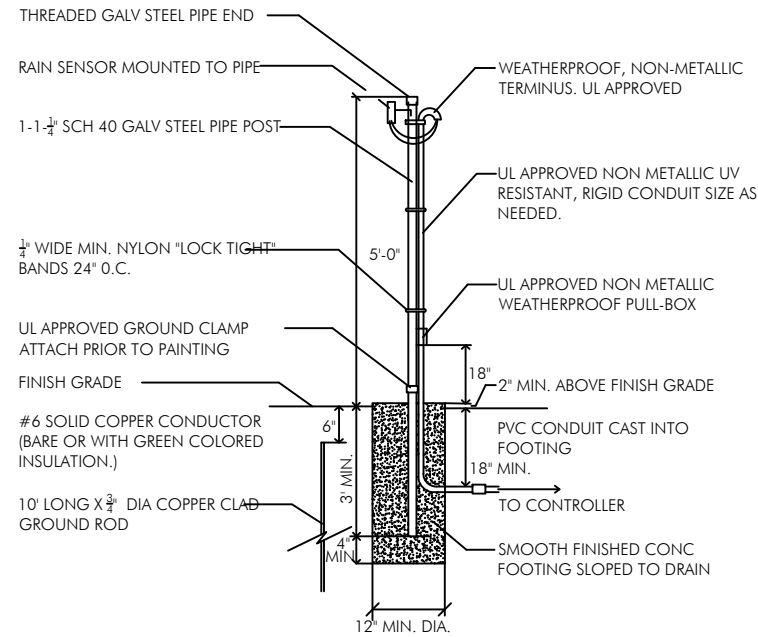

RAIN SENSOR DETAIL

N.T.S.

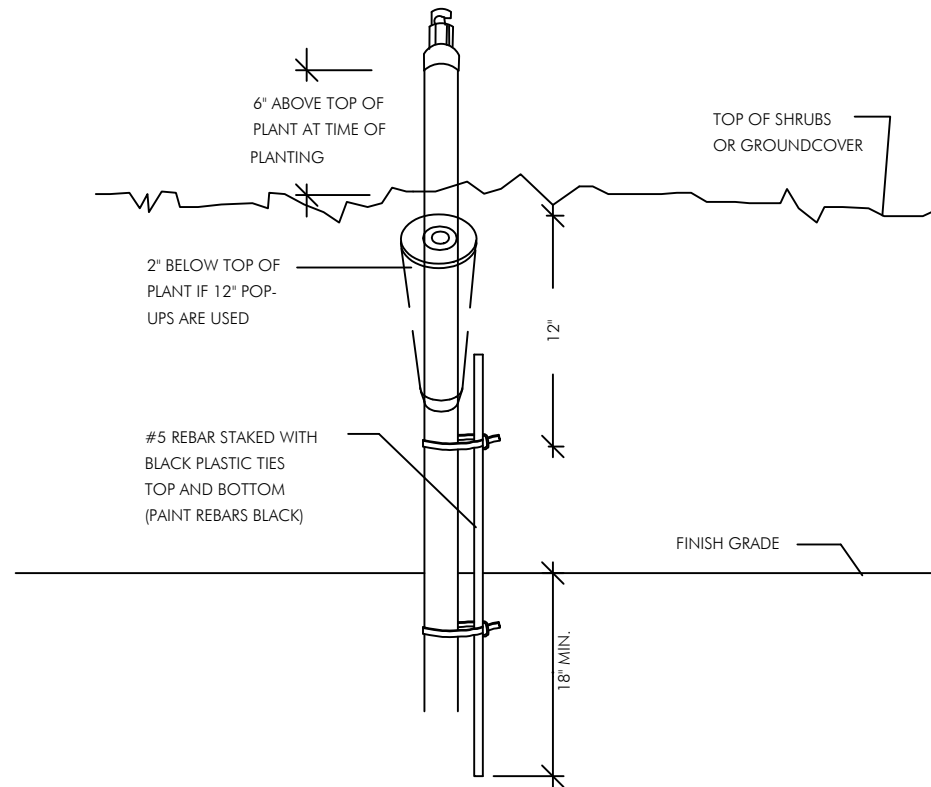

SPRINKLER ON RISER DETAIL FOR SHRUB AREAS

N.T.S.

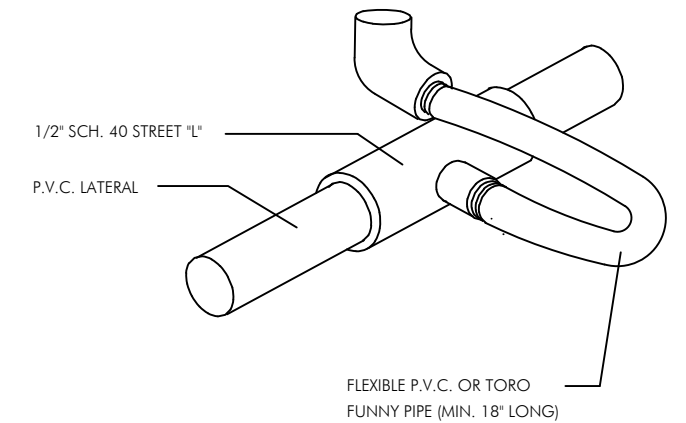

FLEXIBLE SWING JOINT DETAIL

N.T.S.

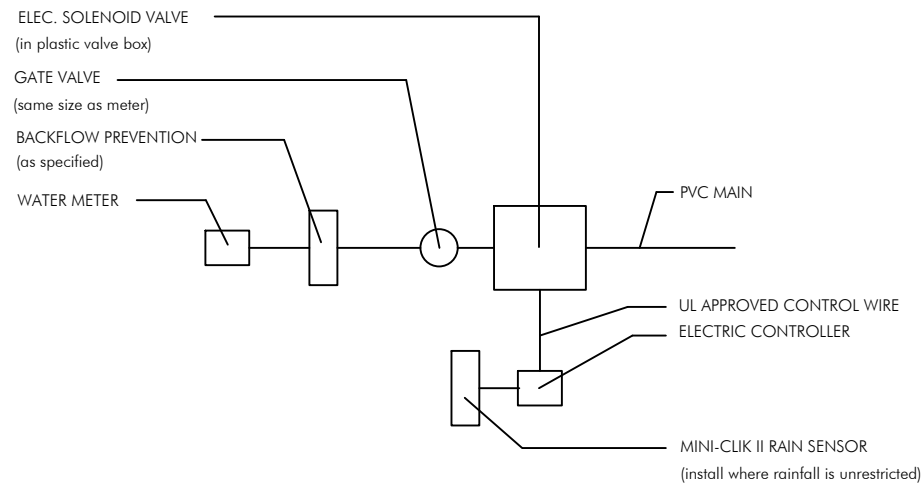

CONNECTION TO METER DETAIL

N.T.S.

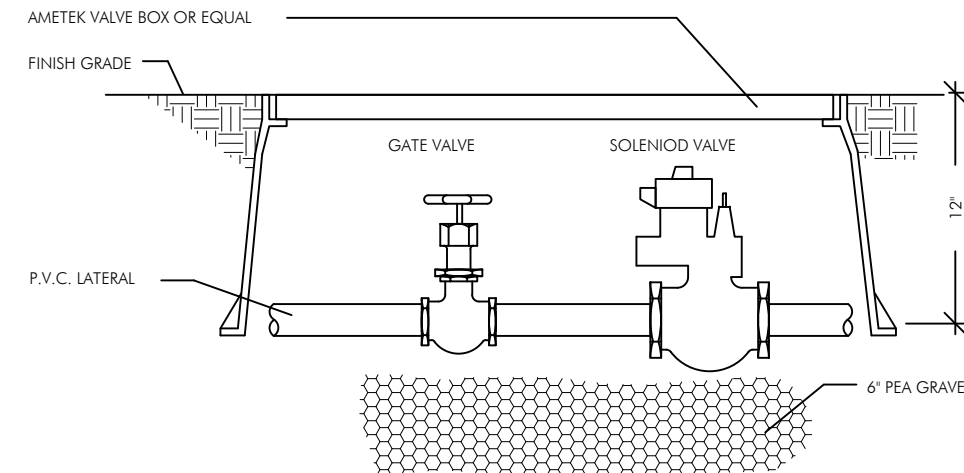

TYPICAL SOLENOID VALVE ASSEMBLY

N.T.S.

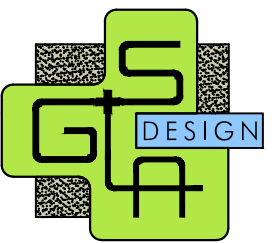

GARDNER + SEMLER
 LANDSCAPE ARCHITECTURE
 WWW.GSLADESIGN.COM
 17670 NW 78th AVE., SUITE 214
 MIAMI, FL 33015
 P 305.392.1016 F 305.392.1019
 CORP. ID # 0000266

ARQUITECTONICA

2900 Oak Avenue, Miami, FL 33133
 T 305.372.1812 F 305.372.1175

ALL DESIGNS INDICATED IN THESE DRAWINGS ARE PROPERTY OF ARQUITECTONICA INTERNATIONAL CORP. NO COPIES, TRANSMISSIONS, REPRODUCTIONS OR ELECTRONIC MANIPULATION OF ANY PORTION OF THESE DRAWINGS IN THE WHOLE OR IN PART ARE TO BE MADE WITHOUT THE EXPRESS WRITTEN AUTHORIZATION OF ARQUITECTONICA INTERNATIONAL CORP. DESIGN INTENT SHOWN IS SUBJECT TO REVIEW AND APPROVAL OF ALL APPLICABLE LOCAL AND GOVERNMENTAL AUTHORITIES HAVING JURISDICTION. ALL COPYRIGHTS RESERVED © 2021.
 THE DATA INCLUDED IN THIS STUDY IS CONCEPTUAL IN NATURE AND WILL CONTINUE TO BE MODIFIED THROUGHOUT THE COURSE OF THE PROJECTS DEVELOPMENT WITH THE EVENTUAL INTEGRATION OF STRUCTURAL, MEP AND LIFE SAFETY SYSTEMS. AS THESE ARE FURTHER REFINED, THE NUMBERS WILL BE ADJUSTED ACCORDINGLY.

HPB FINAL SUBMITTAL
 1509 - 1515 WASHINGTON AVE
 MIAMI BEACH, FL 33139

Irrigation Details

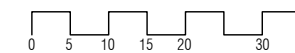

SCALE: 1" = 25'



DATE: MAR 10, 2024 **LA-115**

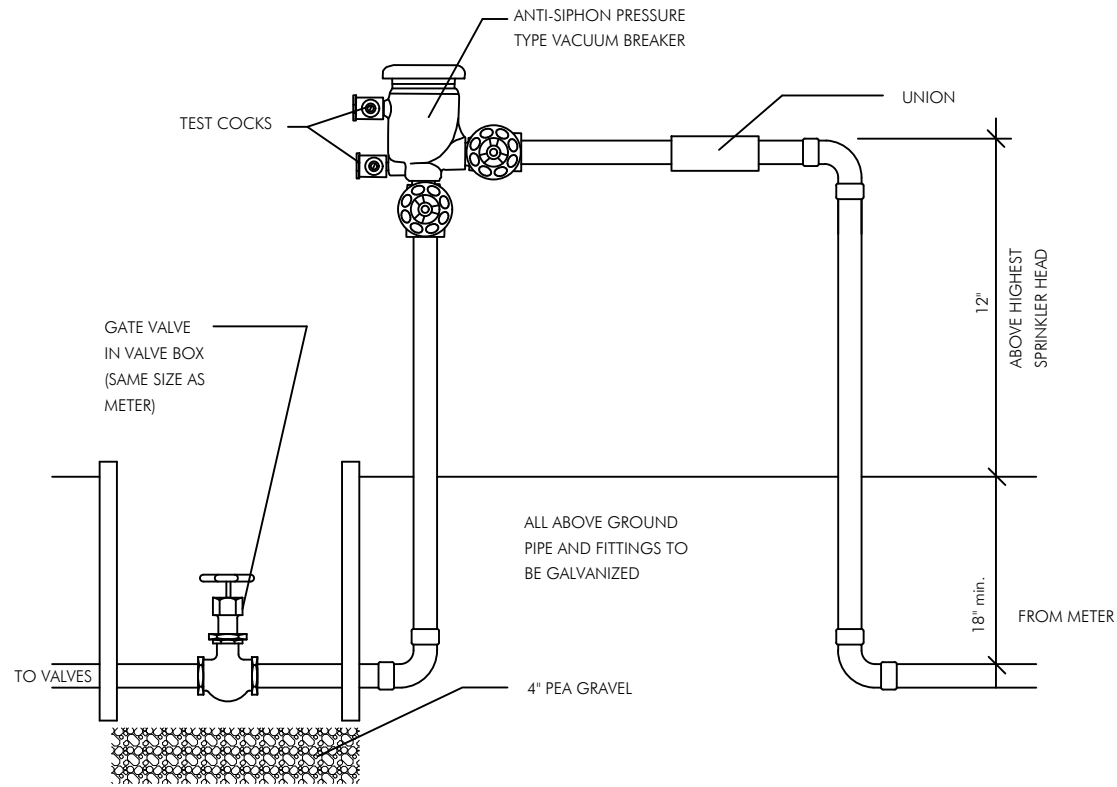

ANTI-SIPHON PRESSURE VACUUM BREAKER DETAIL

N.T.S.

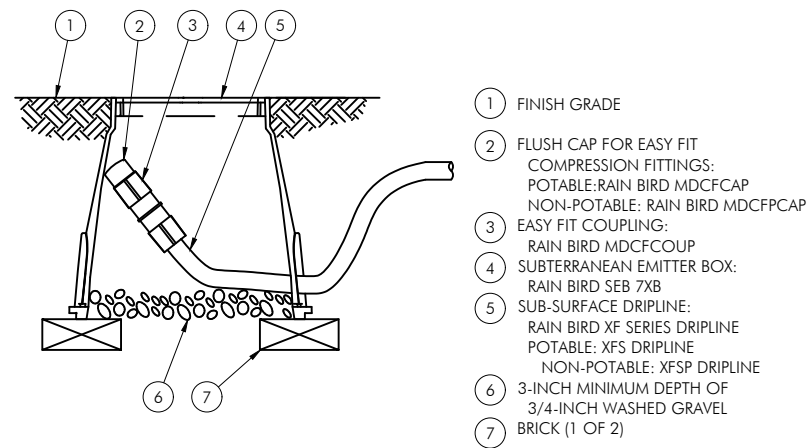

NOTE:
1. ALLOW A MINIMUM OF 6-INCHES OF DRIPLINE TUBING IN VALVE BOX IN ORDER TO DIRECT FLUSHED WATER OUTSIDE VALVE BOX.

XFS DRIPLINE FLUSHPOINT WITH COMPRESSION FITTINGS

N.T.S.

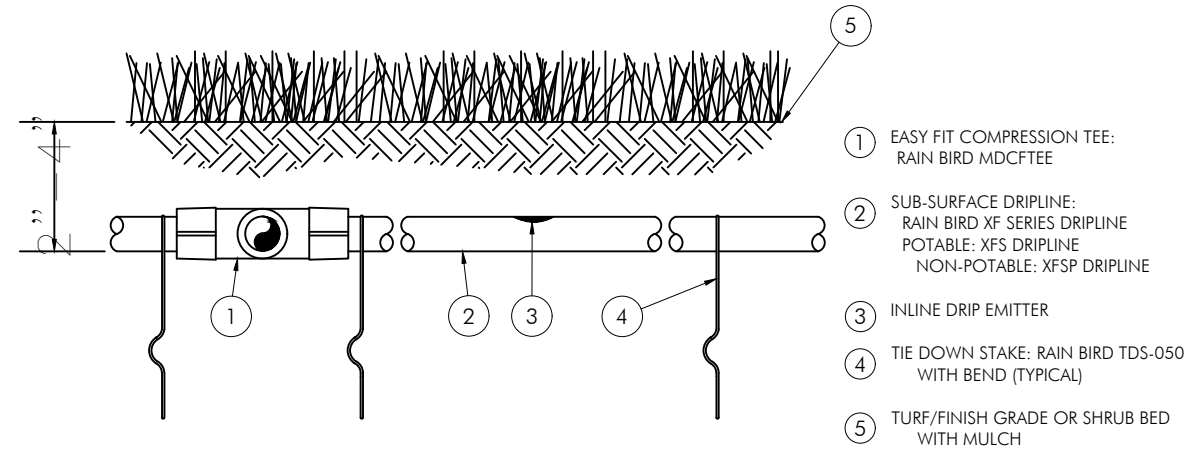

NOTES:
1. PLACE TIE DOWN STAKES EVERY THREE FEET IN SAND, FOUR FEET IN LOAM, AND FIVE FEET IN CLAY.
2. AT FITTINGS WHERE THERE IS A CHANGE OF DIRECTION SUCH AS TEES OR ELBOWS, USE TIE-DOWN STAKES ON EACH LEG OF THE CHANGE OF DIRECTION.
3. INSERTION PLOW AND TRENCHED INSTALLATIONS DO NOT REQUIRE TIE DOWN STAKES.

XFS SUBSURFACE DRIPLINE BURIAL

N.T.S.

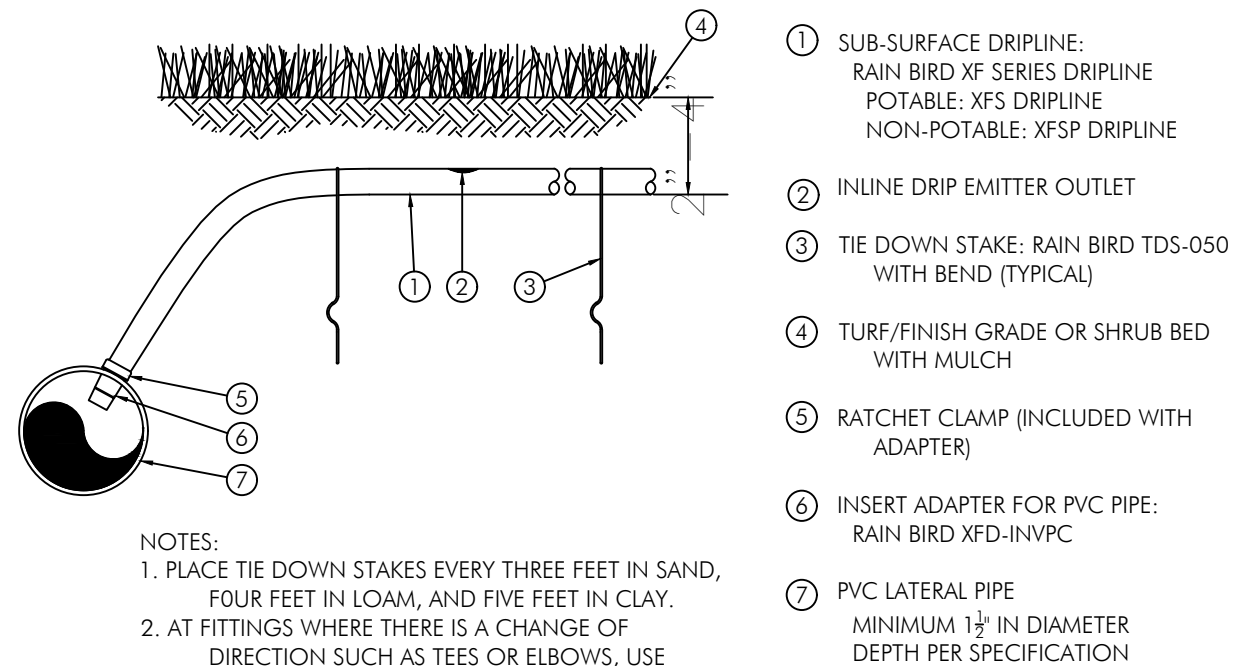

NOTES:
1. PLACE TIE DOWN STAKES EVERY THREE FEET IN SAND, FOUR FEET IN LOAM, AND FIVE FEET IN CLAY.
2. AT FITTINGS WHERE THERE IS A CHANGE OF DIRECTION SUCH AS TEES OR ELBOWS, USE TIE-DOWN STAKES ON EACH LEG OF THE CHANGE OF DIRECTION.
3. INSERTION PLOW AND TRENCHED INSTALLATIONS DO NOT REQUIRE TIE DOWN STAKES.

XFS SUBSURFACE DRIPLINE ADAPTER FOR PVC

N.T.S.



GARDNER + SEMLER
LANDSCAPE ARCHITECTURE
WWW.GSLADDESIGN.COM
17670 NW 78th AVE., SUITE 214
MIAMI, FL 33015
P 305.392.1016 F 305.392.1019
CORP. 1 D # 0 0 0 2 6 6

ARQUITECTONICA

2900 Oak Avenue, Miami, FL 33133
T 305.372.1812 F 305.372.1175

ALL DESIGNS INDICATED IN THESE DRAWINGS ARE PROPERTY OF ARQUITECTONICA INTERNATIONAL CORP. NO COPIES, TRANSMISSIONS, REPRODUCTIONS OR ELECTRONIC MANIPULATION OF ANY PORTION OF THESE DRAWINGS IN THE WHOLE OR IN PART ARE TO BE MADE WITHOUT THE EXPRESS WRITTEN AUTHORIZATION OF ARQUITECTONICA INTERNATIONAL CORP. DESIGN INTENT SHOWN IS SUBJECT TO REVIEW AND APPROVAL OF ALL APPLICABLE LOCAL AND GOVERNMENTAL AUTHORITIES HAVING JURISDICTION. ALL COPYRIGHTS RESERVED © 2021.
THE DATA INCLUDED IN THIS STUDY IS CONCEPTUAL IN NATURE AND WILL CONTINUE TO BE MODIFIED THROUGHOUT THE COURSE OF THE PROJECTS DEVELOPMENT WITH THE EVENTUAL INTEGRATION OF STRUCTURAL, MEP AND LIFE SAFETY SYSTEMS. AS THESE ARE FURTHER REFINED, THE NUMBERS WILL BE ADJUSTED ACCORDINGLY.

HPB FINAL SUBMITTAL
1509 - 1515 WASHINGTON AVE
MIAMI BEACH, FL 33139

Irrigation Details

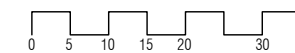

SCALE: 1" = 25'



DATE:
MAR 10, 2024 **LA-116**

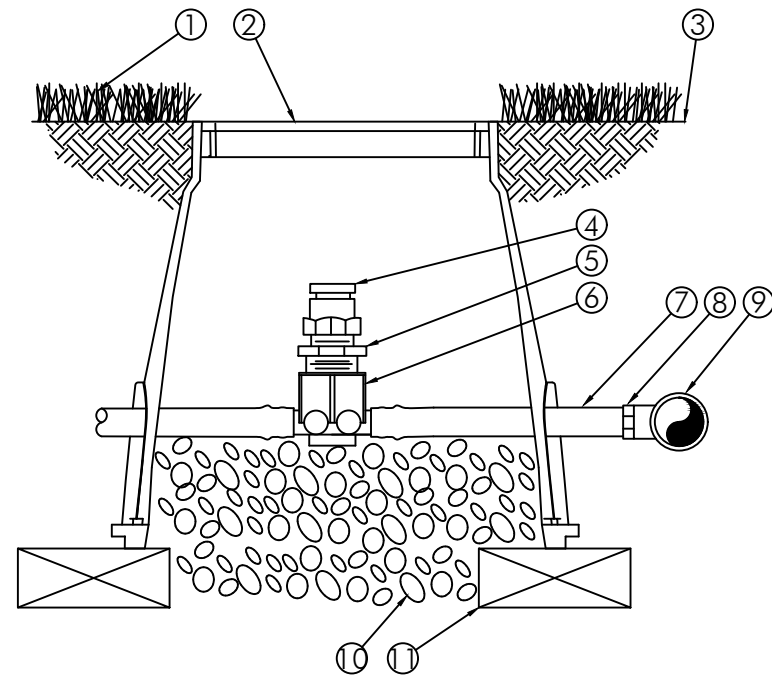

- ① TURF GRASS
- ② SUBTERRANEAN EMITTER BOX:
RAIN BIRD SEB 7XB
- ③ FINISH GRADE
- ④ 1/2" AIR RELIEF VALVE:
RAIN BIRD ARV050
TO BE INSTALLED AT HIGH POINTS IN
DRIP ZONE
- ⑤ 1/2" X 3/4" PVC REDUCER BUSHING
- ⑥ BARB X FEMALE THREAD CONNECTOR:
RAIN BIRD XFD-TFA FITTING
- ⑦ 1/2" BLANK DRIPLINE TUBING:
RAIN BIRD XF SERIES
- ⑧ BARB X MALE THREAD CONNECTOR:
RAIN BIRD XFF-MA FITTING
- ⑨ PVC TEE CONNECTED TO PVC HEADER
PIPE
- ⑩ 3" MINIMUM DEPTH OF
3/4" WASHED GRAVEL
- ⑪ BRICK (1 OF 2)

XFS AIR/VACUUM RELIEF

N.T.S.

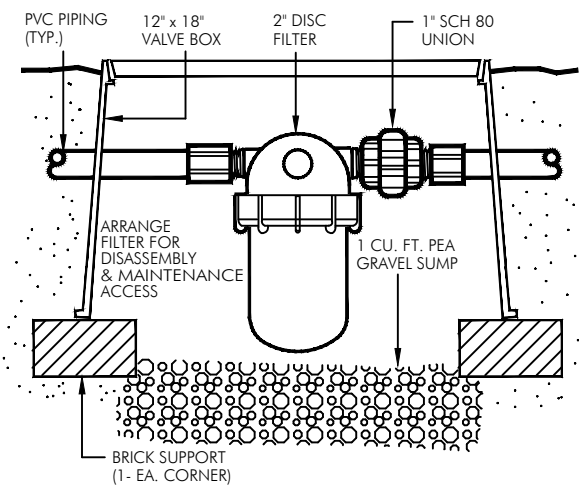

2" DISC FILTER

N.T.S.

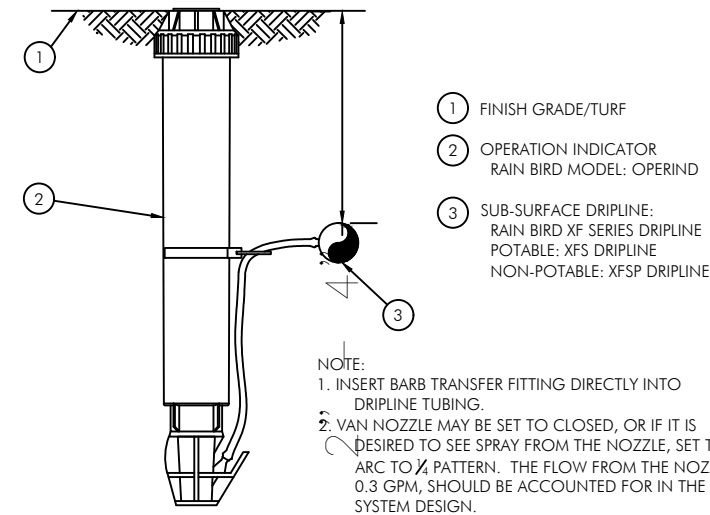

XFS SUBSURFACE DRIPLINE OPERATION INDICATOR

N.T.S.

- ① FINISH GRADE/TURF
 - ② OPERATION INDICATOR
RAIN BIRD MODEL: OPERIND
 - ③ SUB-SURFACE DRIPLINE:
RAIN BIRD XF SERIES DRIPLINE
POTABLE: XFS DRIPLINE
NON-POTABLE: XFSP DRIPLINE
- NOTE:
1. INSERT BARB TRANSFER FITTING DIRECTLY INTO
DRIPLINE TUBING.
2. VAN NOZZLE MAY BE SET TO CLOSED, OR IF IT IS
DESIRED TO SEE SPRAY FROM THE NOZZLE, SET THE
ARC TO 1/4" PATTERN. THE FLOW FROM THE NOZZLE,
0.3 GPM, SHOULD BE ACCOUNTED FOR IN THE
SYSTEM DESIGN.

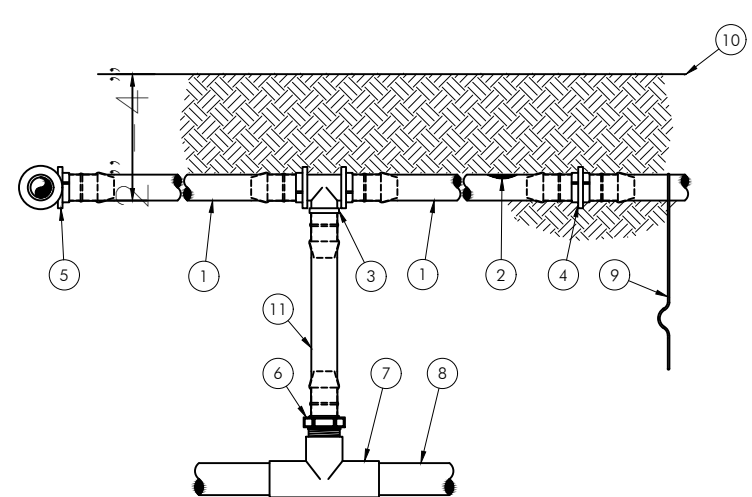

- ① ON-SURFACE DRIPLINE:
RAIN BIRD XF SERIES DRIPLINE
POTABLE: XFS DRIPLINE
NON-POTABLE: XFSP DRIPLINE
- ② INLINE DRIP EMITTER OUTLET, SEE PLANS
FOR DRIPLINE OUTLET SPACING.
- ③ BARB TEE 17x17x17mm
RAIN BIRD XFF-TEE
- ④ BARB COUPLING 17x17mm
RAIN BIRD XFF-COUP
- ⑤ BARB ELBOW 17x17mm
RAIN BIRD XFF-ELBOW
- ⑥ BARB MALE ADAPTER
17mm X 1/2" MPT
RAIN BIRD XFF-MA-050
17mm X 3/4" MPT
RAIN BIRD XFF-MA-075
- ⑦ PVC TEE SxSxT
- ⑧ PVC LATERAL SUPPLY HEADER
- ⑨ TIE-DOWN STAKE:
RAIN BIRD TDS-050 WITH BEND (TYPICAL)
- ⑩ FINISH GRADE
- ⑪ RAIN BIRD XF SERIES BLANK TUBING
LENGTH AS REQUIRED

NOTES:
1. PLACE TIE-DOWN STAKES EVERY THREE FEET IN SAND, FOUR FEET IN LOAM, AND FIVE FEET IN CLAY.
2. AT FITTINGS WHERE THERE IS A CHANGE OF DIRECTION SUCH AS TEES OR ELBOWS, USE TIE-DOWN STAKES ON EACH LEG OF THE CHANGE OF DIRECTION.
3. SAVE YOUR HANDS. USE THE RAIN BIRD FITTINGS-TOOL XF INSERTION TOOL FOR FITTING ASSEMBLY.

XFS SUBSURFACE DRIPLINE RISER ASSEMBLY

N.T.S.



GARDNER + SEMLER
LANDSCAPE ARCHITECTURE
WWW.GSLDESIGN.COM
17670 NW 78th AVE., SUITE 214
MIAMI, FL 33015
P 305.392.1016 F 305.392.1019
CORP. 1 D # 0 0 0 2 6 6

ARQUITECTONICA

2900 Oak Avenue, Miami, FL 33133
T 305.372.1812 F 305.372.1175

ALL DESIGNS INDICATED IN THESE DRAWINGS ARE PROPERTY OF ARQUITECTONICA INTERNATIONAL CORP. NO COPIES, TRANSMISSIONS, REPRODUCTIONS OR ELECTRONIC MANIPULATION OF ANY PORTION OF THESE DRAWINGS IN THE WHOLE OR IN PART ARE TO BE MADE WITHOUT THE EXPRESS WRITTEN AUTHORIZATION OF ARQUITECTONICA INTERNATIONAL CORP. DESIGN INTENT SHOWN IS SUBJECT TO REVIEW AND APPROVAL OF ALL APPLICABLE LOCAL AND GOVERNMENTAL AUTHORITIES HAVING JURISDICTION. ALL COPYRIGHTS RESERVED © 2021.
THE DATA INCLUDED IN THIS STUDY IS CONCEPTUAL IN NATURE AND WILL CONTINUE TO BE MODIFIED THROUGHOUT THE COURSE OF THE PROJECTS DEVELOPMENT WITH THE EVENTUAL INTEGRATION OF STRUCTURAL, MEP AND LIFE SAFETY SYSTEMS. AS THESE ARE FURTHER REFINED, THE NUMBERS WILL BE ADJUSTED ACCORDINGLY.

HPB FINAL SUBMITTAL
1509 - 1515 WASHINGTON AVE
MIAMI BEACH, FL 33139

Irrigation Details

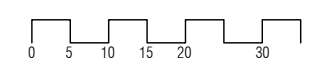

SCALE: 1" = 25'



DATE:
MAR 10, 2024 **LA-117**

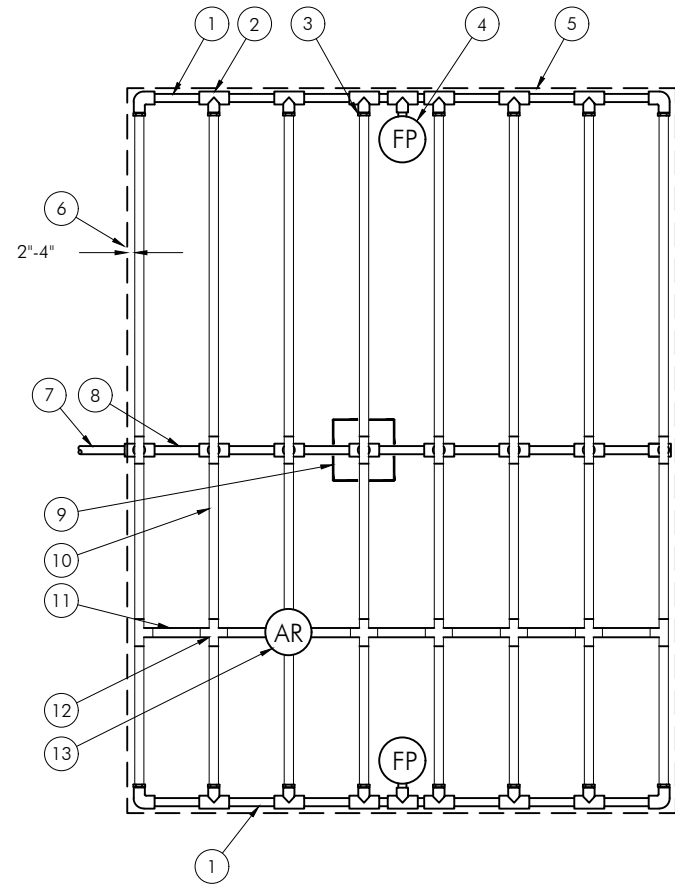

- ① PVC EXHAUST HEADER
- ② PVC SCH 40 TEE OR EL (TYPICAL)
- ③ BARB X MALE FITTING:
RAIN BIRD XFF-MA FITTING (TYPICAL)
- ④ FLUSH POINT (TYPICAL)
SEE RAIN BIRD DETAIL "XFS FLUSH POINT" OR "XFS
FLUSH POINT WITH BALL VALVE"
- ⑤ PERIMETER OF AREA
- ⑥ PERIMETER DRIPLINE PIPE TO BE INSTALLED 2'-4"
FROM PERIMETER OF AREA
- ⑦ PVC SUPPLY PIPE FROM RAIN BIRD CONTROL ZONE
KIT (SIZED TO MEET LATERAL FLOW DEMAND)
- ⑧ PVC SUPPLY MANIFOLD
- ⑨ CONNECTION FROM SUPPLY MANIFOLD TO
DRIPLINE (TYPICAL)- SEE INSET A
- ⑩ SUB-SURFACE DRIPLINE:
RAIN BIRD XF SERIES DRIPLINE (TYPICAL)
POTABLE: XFS DRIPLINE
NON-POTABLE: XFSP DRIPLINE
- ⑪ RAIN BIRD XF SERIES BLANK TUBING
- ⑫ BARB X BARB INSERT TEE OR CROSS:
RAIN BIRD XFF-TEE OR
RAIN BIRD XFD-CROSS (TYPICAL)
- ⑬ ½" AIR RELIEF VALVE: RAIN BIRD MODEL:
ARV050
SEE RAIN BIRD XFS DETAILS FOR AIR RELIEF
INSTALLATION
- ⑭ BARB X FEMALE FITTING:
RAIN BIRD XFD-TFA-075 FITTING
- ⑮ ¾" PVC NIPPLE, LENGTH AS NECESSARY

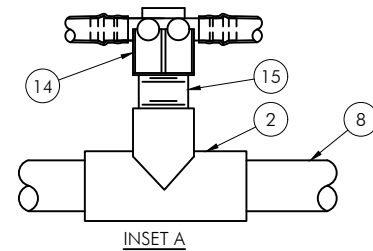

XFS Dripline Maximum Lateral Lengths (Feet)						
Inlet Pressure psi	12" Spacing		18" Spacing		24" Spacing	
	Nominal Flow (gph)		Nominal Flow (gph)		Nominal Flow (gph)	
	0.6	0.9	0.6	0.9	0.6	0.9
15	273	155	314	250	424	322
20	318	169	353	294	508	368
30	360	230	413	350	586	414
40	395	255	465	402	652	474
50	417	285	528	420	720	488
60	460	290	596	455	780	514

- NOTES:
- DISTANCE BETWEEN LATERAL ROWS AND EMITTER SPACING TO BE BASED ON SOIL TYPE, PLANT MATERIALS AND CHANGES IN ELEVATION. SEE RAIN BIRD XF-SDI DRIPLINE INSTALLATION GUIDE FOR SUGGESTED SPACINGS.
 - LENGTH OF LONGEST DRIPLINE LATERAL SHOULD NOT EXCEED THE MAXIMUM LENGTH SHOWN IN THE ACCOMPANYING TABLE.
 - AIR RELIEF VALVE TO BE INSTALLED AT HIGH POINT OF AREA.
 - WHEN USING 17MM INSERT FITTINGS WITH DESIGN PRESSURE OVER 50PSI, IT IS RECOMMENDED THAT STAINLESS STEEL CLAMPS BE INSTALLED ON EACH FITTING.

XFS SUBSURFACE DRIPLINE CENTERFEED LAYOUT

N.T.S.



GARDNER + SEMLER
LANDSCAPE ARCHITECTURE
WWW.GSLDESIGN.COM
17670 NW 78th AVE., SUITE 214
MIAMI, FL 33015
P 305.392.1016 F 305.392.1019
CORP. ID # 0000266

ARQUITECTONICA

2900 Oak Avenue, Miami, FL 33133
T 305.372.1812 F 305.372.1175

ALL DESIGNS INDICATED IN THESE DRAWINGS ARE PROPERTY OF ARQUITECTONICA INTERNATIONAL CORP. NO COPIES, TRANSMISSIONS, REPRODUCTIONS OR ELECTRONIC MANIPULATION OF ANY PORTION OF THESE DRAWINGS IN THE WHOLE OR IN PART ARE TO BE MADE WITHOUT THE EXPRESS WRITTEN AUTHORIZATION OF ARQUITECTONICA INTERNATIONAL CORP. DESIGN INTENT SHOWN IS SUBJECT TO REVIEW AND APPROVAL OF ALL APPLICABLE LOCAL AND GOVERNMENTAL AUTHORITIES HAVING JURISDICTION. ALL COPYRIGHTS RESERVED © 2021.
THE DATA INCLUDED IN THIS STUDY IS CONCEPTUAL IN NATURE AND WILL CONTINUE TO BE MODIFIED THROUGHOUT THE COURSE OF THE PROJECTS DEVELOPMENT WITH THE EVENTUAL INTEGRATION OF STRUCTURAL, MEP AND LIFE SAFETY SYSTEMS. AS THESE ARE FURTHER REFINED, THE NUMBERS WILL BE ADJUSTED ACCORDINGLY.

HPB FINAL SUBMITTAL
1509 - 1515 WASHINGTON AVE
MIAMI BEACH, FL 33139

Irrigation Details

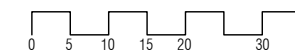

SCALE: 1" = 25'



DATE:
MAR 10, 2024

LA-118

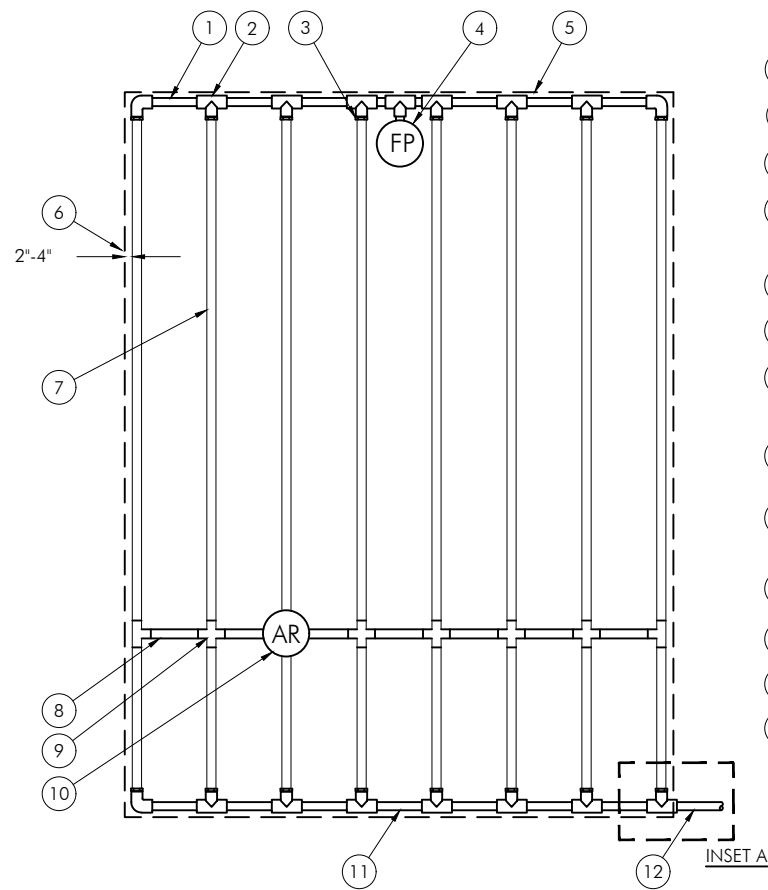

- ① PVC EXHAUST HEADER
- ② PVC SCH 40 TEE OR EL (TYPICAL)
- ③ BARB X MALE FITTING:
RAIN BIRD XFF-MA FITTING (TYPICAL)
- ④ FLUSH POINT (TYPICAL)
SEE RAIN BIRD DETAIL "XFS FLUSH POINT" OR "XFS FLUSH POINT WITH BALL VALVE"
- ⑤ PERIMETER OF AREA
- ⑥ PERIMETER DRIPLINE PIPE TO BE INSTALLED 2"-4" FROM PERIMETER OF AREA
- ⑦ SUB-SURFACE DRIPLINE:
RAIN BIRD XF SERIES DRIPLINE (TYPICAL)
POTABLE: XFS DRIPLINE
NON-POTABLE: XFS DRIPLINE
- ⑧ RAIN BIRD XF SERIES BLANK TUBING
- ⑨ BARB X BARB INSERT TEE OR CROSS:
RAIN BIRD XFF-TEE OR
RAIN BIRD XFD-CROSS (TYPICAL)
- ⑩ ½" AIR RELIEF VALVE: RAIN BIRD MODEL: ARV050
SEE RAIN BIRD XFS DETAILS FOR AIR RELIEF INSTALLATION
- ⑪ PVC SUPPLY HEADER
- ⑫ PVC DRIP MANIFOLD FROM RAIN BIRD CONTROL ZONE VALVE KIT (SIZED TO MEET LATERAL FLOW DEMAND)
- ⑬ PVC SCH 40 RISER PIPE

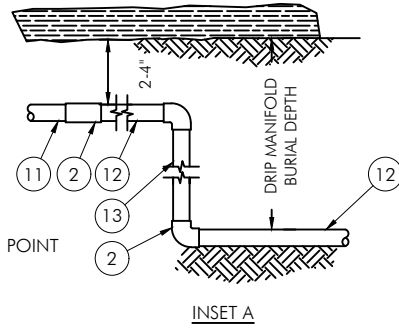

Inlet Pressure psi	12" Spacing		18" Spacing		24" Spacing	
	Nominal Flow (gph)	Nominal Flow (gph)	Nominal Flow (gph)	Nominal Flow (gph)	Nominal Flow (gph)	Nominal Flow (gph)
15	273	155	314	250	424	322
20	318	169	353	294	508	368
30	360	230	413	350	586	414
40	395	255	465	402	652	474
50	417	285	528	420	720	488
60	460	290	596	455	780	514

- NOTES:
- DISTANCE BETWEEN LATERAL ROWS AND EMITTER SPACING TO BE BASED ON SOIL TYPE, PLANT MATERIALS AND CHANGES IN ELEVATION. SEE RAIN BIRD XFS DRIPLINE INSTALLATION GUIDE FOR SUGGESTED SPACINGS.
 - LENGTH OF LONGEST DRIPLINE LATERAL SHOULD NOT EXCEED THE MAXIMUM LENGTH SHOWN IN THE ACCOMPANYING TABLE.
 - AIR RELIEF VALVE TO BE INSTALLED AT HIGH POINT OF AREA.
 - WHEN USING 17MM INSERT FITTINGS WITH DESIGN PRESSURE OVER 50PSI, IT IS RECOMMENDED THAT STAINLESS STEEL CLAMPS BE INSTALLED ON EACH FITTING.

XFS SUBSURFACE DRIPLINE END FEED LAYOUT

N.T.S.

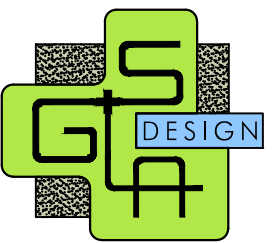

GARDNER + SEMLER
LANDSCAPE ARCHITECTURE
WWW.GSLDESIGN.COM
17670 NW 78th AVE., SUITE 214
MIAMI, FL 33015
P 305.392.1016 F 305.392.1019
CORP. 1D # 0000266

ARQUITECTONICA

2900 Oak Avenue, Miami, FL 33133
T 305.372.1812 F 305.372.1175

ALL DESIGNS INDICATED IN THESE DRAWINGS ARE PROPERTY OF ARQUITECTONICA INTERNATIONAL CORP. NO COPIES, TRANSMISSIONS, REPRODUCTIONS OR ELECTRONIC MANIPULATION OF ANY PORTION OF THESE DRAWINGS IN THE WHOLE OR IN PART ARE TO BE MADE WITHOUT THE EXPRESS WRITTEN AUTHORIZATION OF ARQUITECTONICA INTERNATIONAL CORP. DESIGN INTENT SHOWN IS SUBJECT TO REVIEW AND APPROVAL OF ALL APPLICABLE LOCAL AND GOVERNMENTAL AUTHORITIES HAVING JURISDICTION. ALL COPYRIGHTS RESERVED © 2021.
THE DATA INCLUDED IN THIS STUDY IS CONCEPTUAL IN NATURE AND WILL CONTINUE TO BE MODIFIED THROUGHOUT THE COURSE OF THE PROJECTS DEVELOPMENT WITH THE EVENTUAL INTEGRATION OF STRUCTURAL, MEP AND LIFE SAFETY SYSTEMS. AS THESE ARE FURTHER REFINED, THE NUMBERS WILL BE ADJUSTED ACCORDINGLY.

HPB FINAL SUBMITTAL
1509 - 1515 WASHINGTON AVE
MIAMI BEACH, FL 33139

Irrigation Details



SCALE: 1" = 25'



DATE:
MAR 10, 2024

LA-119

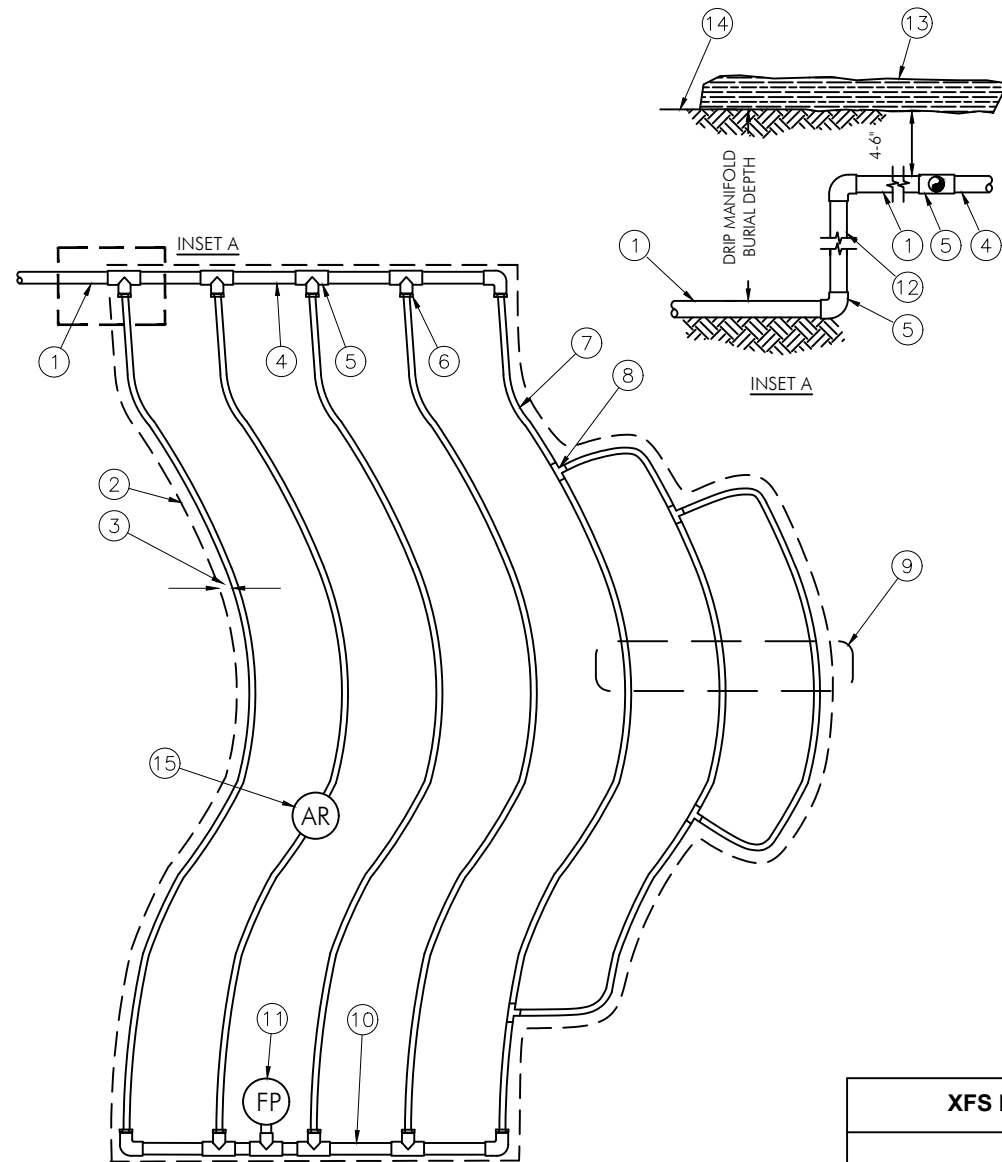

- ① PVC SUPPLY PIPE FROM RAIN BIRD CONTROL ZONE KIT (SIZED TO MEET LATERAL FLOW DEMAND)
- ② PERIMETER OF AREA
- ③ PERIMETER DRIPLINE PIPE TO BE INSTALLED 2"-4" FROM PERIMETER OF AREA
- ④ PVC SUPPLY MANIFOLD
- ⑤ PVC SCH 40 TEE OR EL (TYPICAL)
- ⑥ BARB X MALE FITTING: RAIN BIRD XFF-MA FITTING (TYPICAL)
- ⑦ SUB-SURFACE DRIPLINE: RAIN BIRD XF SERIES DRIPLINE (TYPICAL)
POTABLE: XFS DRIPLINE
NON-POTABLE: XFSP DRIPLINE
- ⑧ BARB X BARB INSERT TEE: RAIN BIRD XFF-TEE (TYPICAL)
- ⑨ TOTAL LENGTH OF SELECTED DRIPLINE SHOULD NOT EXCEED LENGTH SHOWN IN TABLE
- ⑩ PVC FLUSH HEADER
- ⑪ FLUSH POINT: SEE RAIN BIRD XFS DETAILS FOR FLUSH POINT INSTALLATION
- ⑫ PVC RISER PIPE
- ⑬ TURF OR MULCH
- ⑭ FINISH GRADE
- ⑮ ½" AIR RELIEF VALVE: RAIN BIRD MODEL: ARV050
SEE RAIN BIRD XFS DETAILS FOR AIR RELIEF INSTALLATION

NOTES:

- 1. DISTANCE BETWEEN LATERAL ROWS AND EMITTER SPACING TO BE BASED ON SOIL TYPE, PLANT MATERIALS AND CHANGES IN ELEVATION. SEE INSTALLATION SPECIFICATIONS ON RAIN BIRD WEB SITE (WWW.RAINBIRD.COM) FOR SUGGESTED SPACING.
- 2. LENGTH OF LONGEST DRIPLINE LATERAL SHOULD NOT EXCEED THE MAXIMUM SPACING SHOWN IN THE ACCOMPANYING TABLE.
- 3. INSTALL AIR RELIEF VALVE AT HIGH POINTS IN DRIP LATERAL.
- 4. WHEN USING 17MM INSERT FITTINGS WITH DESIGN PRESSURE OVER 50PSI, IT IS RECOMMENDED THAT STAINLESS STEEL CLAMPS BE INSTALLED ON EACH FITTING.

XFS Dripline Maximum Lateral Lengths (Feet)						
Inlet Pressure psi	12" Spacing		18" Spacing		24" Spacing	
	Nominal Flow (gph)	Nominal Flow (gph)	Nominal Flow (gph)	Nominal Flow (gph)	Nominal Flow (gph)	Nominal Flow (gph)
15	0.6	0.9	0.6	0.9	0.6	0.9
20	273	155	314	250	424	322
30	318	169	353	294	508	368
40	360	230	413	350	586	414
50	395	255	465	402	652	474
60	417	285	528	420	720	488
	460	290	596	455	780	514

XFS SUBSURFACE DRIPLINE ODD CURVES LAYOUT

N.T.S.



GARDNER + SEMLER
LANDSCAPE ARCHITECTURE
WWW.GSLADESIGN.COM
17670 NW 78th AVE., SUITE 214
MIAMI, FL 33015
P 305.392.1016 F 305.392.1019
CORP. ID # 0000266

ARQUITECTONICA

2900 Oak Avenue, Miami, FL 33133
T 305.372.1812 F 305.372.1175

ALL DESIGNS INDICATED IN THESE DRAWINGS ARE PROPERTY OF ARQUITECTONICA INTERNATIONAL CORP. NO COPIES, TRANSMISSIONS, REPRODUCTIONS OR ELECTRONIC MANIPULATION OF ANY PORTION OF THESE DRAWINGS IN THE WHOLE OR IN PART ARE TO BE MADE WITHOUT THE EXPRESS WRITTEN AUTHORIZATION OF ARQUITECTONICA INTERNATIONAL CORP. DESIGN INTENT SHOWN IS SUBJECT TO REVIEW AND APPROVAL OF ALL APPLICABLE LOCAL AND GOVERNMENTAL AUTHORITIES HAVING JURISDICTION. ALL COPYRIGHTS RESERVED © 2021.
THE DATA INCLUDED IN THIS STUDY IS CONCEPTUAL IN NATURE AND WILL CONTINUE TO BE MODIFIED THROUGHOUT THE COURSE OF THE PROJECTS DEVELOPMENT WITH THE EVENTUAL INTEGRATION OF STRUCTURAL, MEP AND LIFE SAFETY SYSTEMS. AS THESE ARE FURTHER REFINED, THE NUMBERS WILL BE ADJUSTED ACCORDINGLY.

HPB FINAL SUBMITTAL
1509 - 1515 WASHINGTON AVE
MIAMI BEACH, FL 33139

Irrigation Details

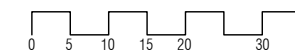

SCALE: 1" = 25'



DATE:
MAR 10, 2024

LA-120