

Historic Preservation Board File No. 20-0442

100 21st Street

KHR The Law Offices of Kent Harrison Robbins, P.A.

Presentation by Law Offices of Kent Harrison Robbins, P.A.
on behalf of the Dempsey-Vanderbilt and the Setai Resort
and Residences Condominium Association, Inc.

June 15, 2021



DEMPSEY-VANDERBILT HOTEL, MIAMI BEACH, FLORIDA

G-549









MASSING

FROM SEAGULL HOTEL / BVLGARI'S PRESENTATION AT APRIL 27, 2021
PLANNING BOARD HEARINGS ON PB FILE NO. 21-0424 (RM3 ORDINANCE)
AND PB FILE NO. 21-0426 (VACATING 21ST ST ROW)

MASSING DIAGRAM

— EXISTING
— NEW CONSTRUCTION

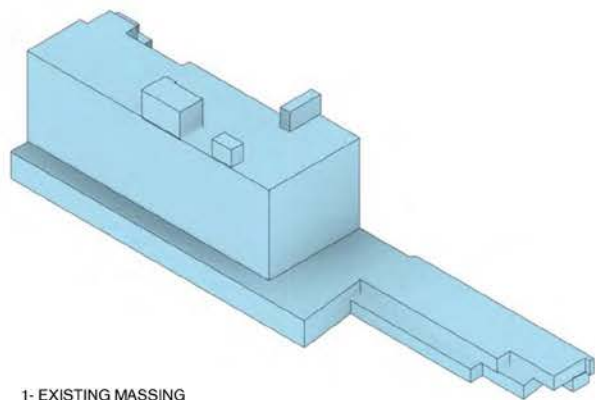

1- EXISTING MASSING

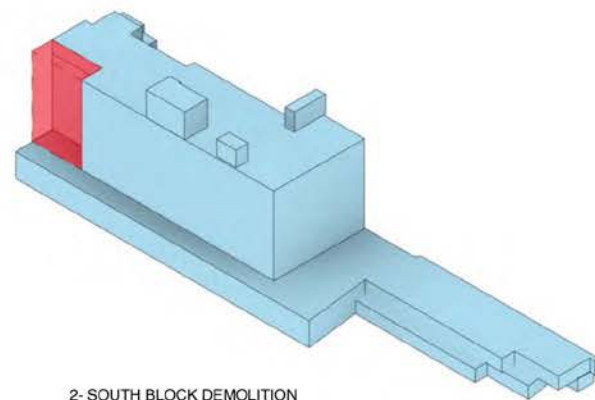

2- SOUTH BLOCK DEMOLITION

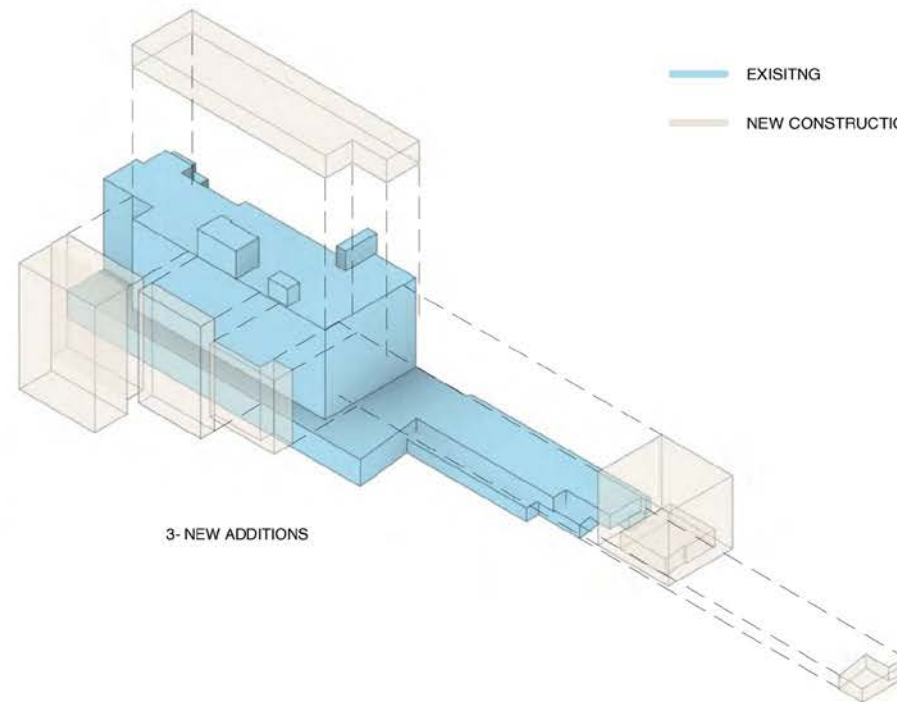

3- NEW ADDITIONS

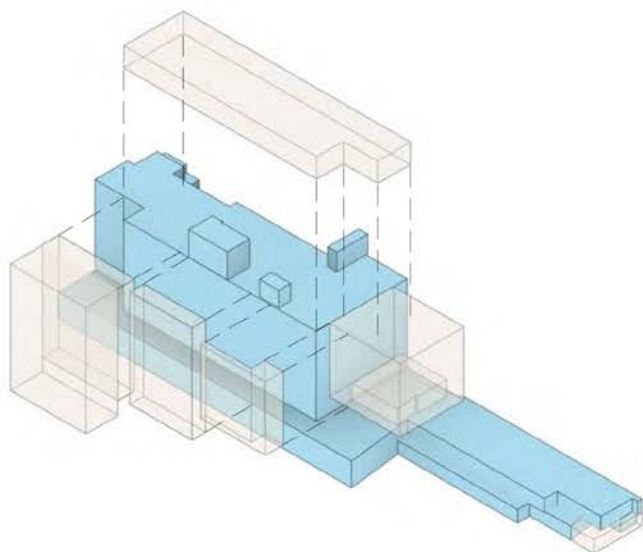

4- EAST BLOCK ADDITION

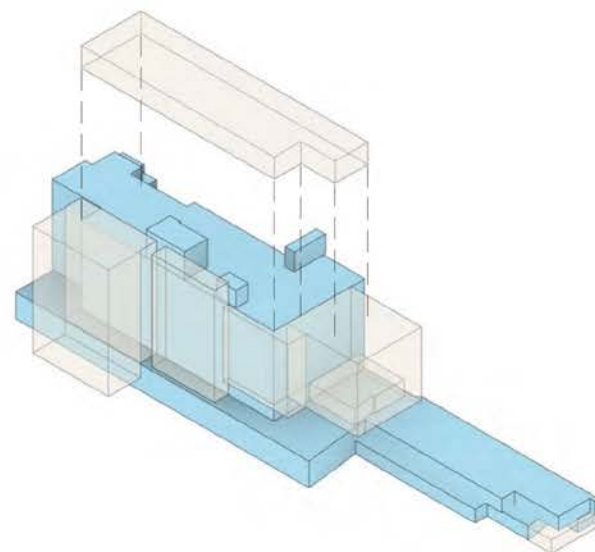

5- SOUTH BLOCK ADDITION

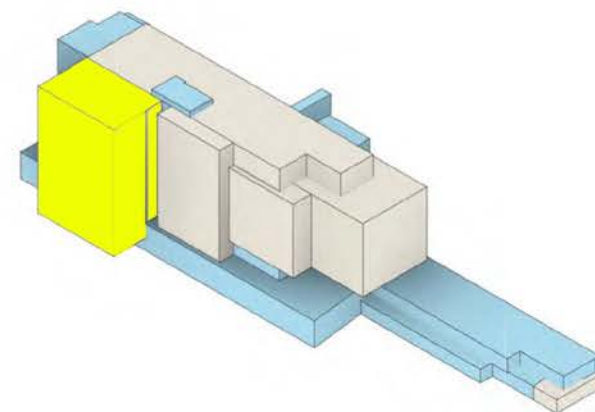

6- ROOF BLOCK ADDITION

GROUND FLOOR ADDITION

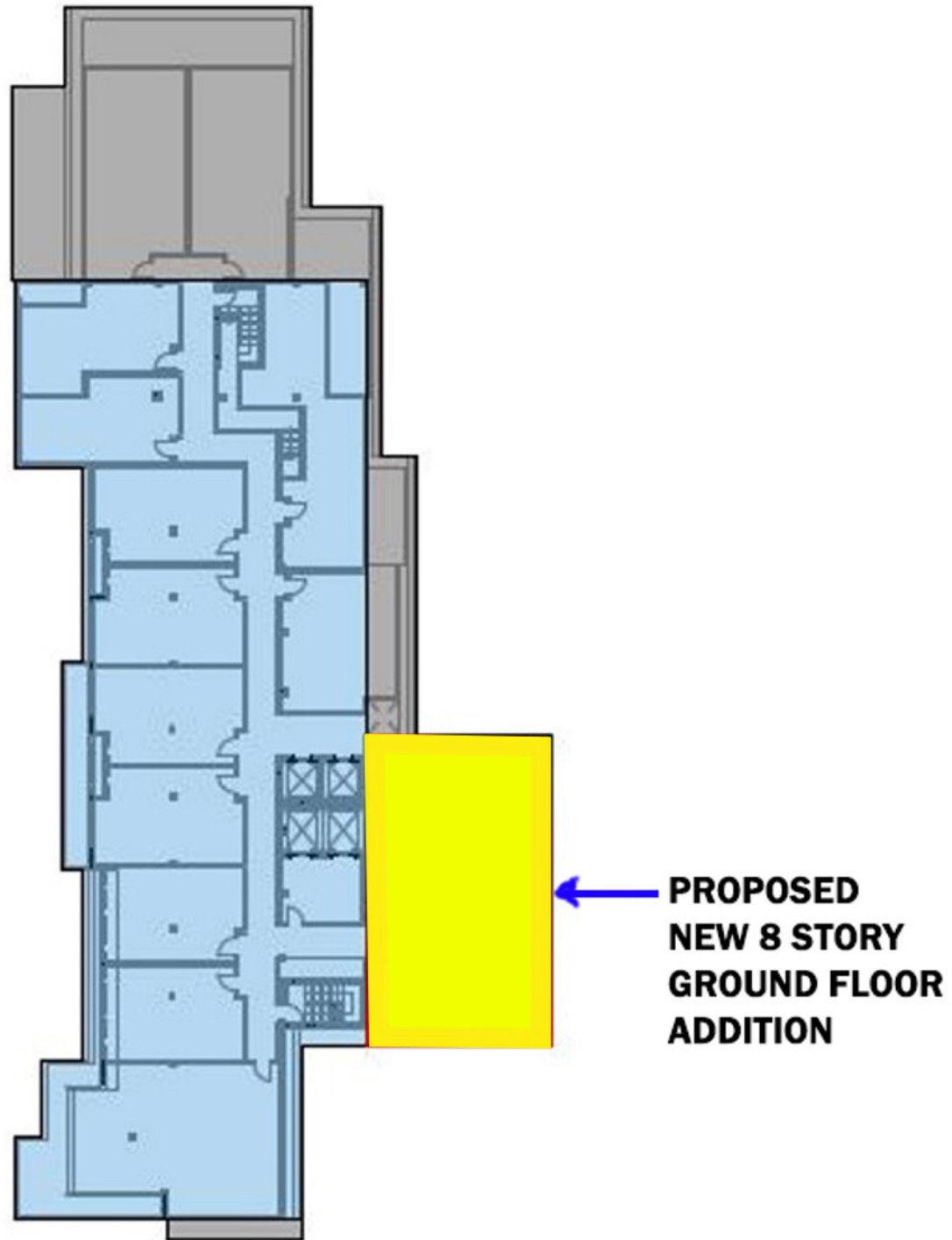

SITE PLAN

EXISTING AND PROPOSED

FROM SEAGULL HOTEL / BVLGARI'S PRESENTATION AT APRIL 27, 2021
PLANNING BOARD HEARINGS ON PB FILE NO. 21-0424 (RM3 ORDINANCE)
AND PB FILE NO. 21-0426 (VACATING 21ST ST ROW)

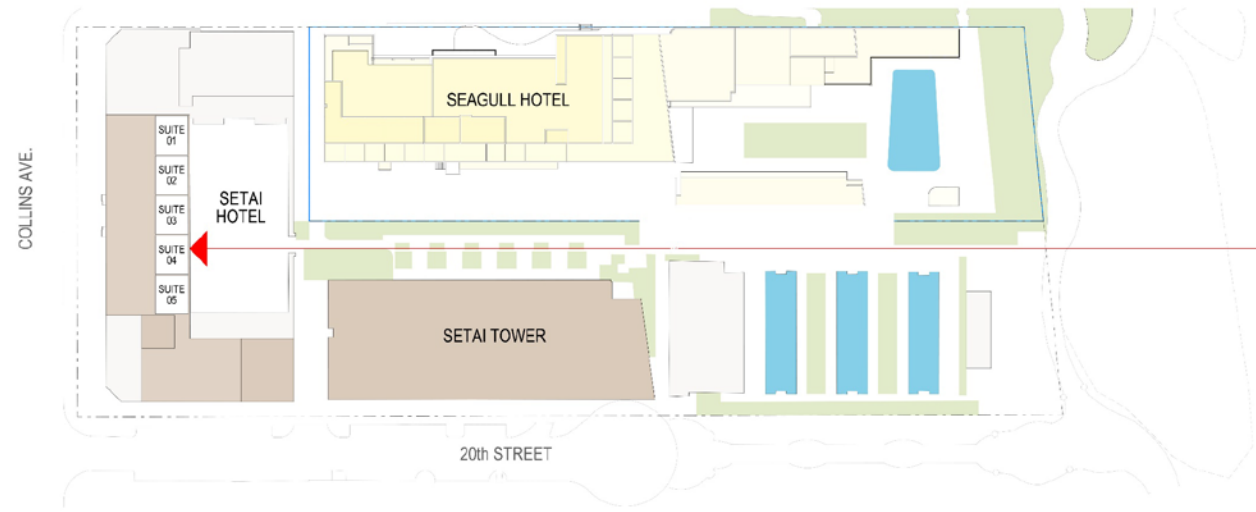

SITE PLAN EXISTING BUILDING | 09

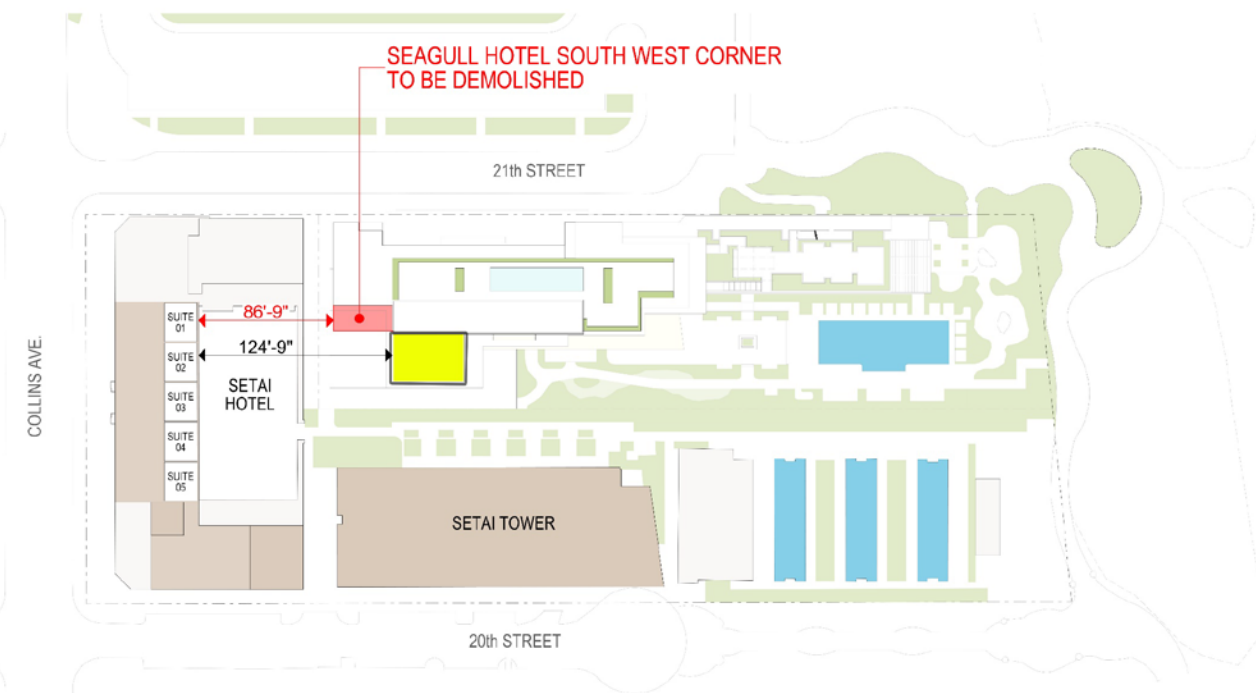

- LEGEND**
- SEAGULL SOUTH ADDITION
 - SEAGULL SOUTH WEST CORNER AREA TO BE DEMOLISHED

SITE PLAN NEW BUILDING | 10

