



April 24, 2020

Mr. David Martinez, P.E.  
 Director of Capital Improvement Projects  
 City of Miami Beach, CIP  
 1701 Meridian Ave CMB CIP Office 3rd Floor  
 Miami Beach, FL

RE: **Proposed Relocation of Transmission Facilities:  
 INDIAN CREEK-NORMANDY BEACH 69kV 17B17 to 17B20**

Dear Mr. Martinez,

We at FPL appreciate the opportunity to work with you on the aforementioned transmission relocation project. The cost estimates for the electric service you have requested is completed and the amount has been determined as follows:

	Cost
Transmission relocation	+\$836,620.94
Additional 20% contingency	+\$167,324.19
Engineering deposit received	- \$154,180.00
<b>Remaining Balance Due</b>	<b>+\$849,765.13</b>

Please note, as discussed with your staff during our project follow up meetings, the scope of work includes only transmission facilities and the City of Miami Beach needs to coordinate all related distribution work with our distribution department.

The relocation amount quoted above is valid from the date of this letter for a period of three (3) months. To facilitate our ability to meet your desired construction schedule, secure the material for the project and schedule the work with our construction department, we would appreciate receiving your payment and the execution of the replacement easement by 07/01/2020.

Sincerely,

A handwritten signature in black ink, appearing to be "RC" or similar initials, written in a cursive style.

Roberto Cruz, P.E.  
 Transmission Engineering Lead  
 Office: 561.904.3662

**Project Description**

**Summary Estimate of Cost**

Dedicated Feeder - Substation work

Project Level

**Project Name:**

CUS SOUTH

**Work Order List (max 6)** T09999-009-0988-001

Line No	Salvage	Removal	Item	Item Cost	Total
6			<b>(A) ENGINEERING</b>		
7			Labor		
8			* Additives of Labor		
9			Transportation		
10			Applied Engineering	\$60,000.00	
11			Contractor & Misc. Expenses		
12			* Additives of Contractor/Misc. Expenses		
13			Sub-total	<u>\$60,000.00</u>	<u>\$60,000.00</u>
14					
15			<b>(B) LAND &amp; LAND RIGHTS (RIGHT OF WAY)</b>		
16			Labor		
17			* Additives of Labor		
18			Transportation Expenses		
19			Purchase and/or Easements		
20			Contractor & Misc. Expenses		
21			* Additives of Contractor & Misc. Expenses		
22			Sub-total		
23					
24			<b>(C) CONSTRUCTION</b>		
25			Labor	\$29,324.99	
26			* Additives of Labor		
27			Transportation Expenses	\$14,544.49	
28			Material	\$163,862.68	
29			* Stores Loading	\$16,424.12	
30			Contractor & Misc. Expenses	\$394,825.32	
31			* Additives of Contractor & Misc. Expenses		
32			Sub-total	<u>\$618,981.60</u>	<u>\$618,981.60</u>
33					
34			<b>(D) OTHER - MAINTENANCE</b>		
35			Labor		
36			* Additives of Labor		
37			Transportation Expenses		
38			Material		
39			* Stores Handling		
40			Contractor & Misc. Expenses		
41			* Additives of Contractor & Misc. Expenses		
42			Sub-total		
43					
44			<b>(E) ADMINISTRATIVE &amp; GENERAL COSTS</b>		
45			Administrative & General Costs	\$157,639.34	
46			Sub-total	<u>\$157,639.34</u>	<u>\$157,639.34</u>
47					
48	<b>\$0.00</b>	<b>\$0.00</b>	<b>GRAND TOTAL</b>	<b>\$836,620.94</b>	<b>\$836,620.94</b>
49			TOTAL INSTALLATION AND MAINTENANCE COST		<u>\$836,620.94</u>
50			TOTAL REMOVAL COST		<u>\$0.00</u>
51			SALVAGE () LESS SALVAGE ADJUSTMENT (FACILITIES NOT REPLACED)		<u>\$0.00</u>
52			SUB-TOTAL		<u>\$836,620.94</u>
53			CREDIT ###.###% (FROM AGREEMENT)		<u>\$0.00</u>
54			NET REPLACEMENT COST (Sum lines 52 and 53)		<u>\$836,620.94</u>

\* Handling, Tax & Insurance and Pension & Welfare at Approved Rates

Engineer: \_\_\_\_\_

Submitted By: \_\_\_\_\_

Michael Foley

**FACILITIES RELOCATION AGREEMENT  
(FPL – TRANSMISSION)**

THIS FACILITIES RELOCATION AGREEMENT (“**Agreement**”) is made and entered into this 24<sup>th</sup> day of April, 2020, by and between the City of Miami Beach CIP (“**Applicant**”), with address at 1701 Meridian Avenue CMB CIP Office, 3<sup>rd</sup> Floor, Miami Beach, FL 33139 and FLORIDA POWER & LIGHT COMPANY, a Florida corporation (“**FPL**”), with its principal place of business at 700 Universe Boulevard, Juno Beach, Florida 33408. Applicant and FPL are sometimes hereinafter individually referred to as a “**Party**” and collectively as the “**Parties.**”

**WITNESSETH:**

WHEREAS, Applicant intends to construct the 72<sup>nd</sup> Street Municipal Complex and will require the relocation of certain incompatible and conflicting portions of FPL's facilities and equipment; and

WHEREAS FPL will incur costs in the relocation of such FPL's facilities and equipment, which costs would not have occurred but for Applicant's construction.

NOW THEREFORE, in consideration of the mutual promises of Applicant and FPL, and other good and valuable consideration, the receipt of sufficiency of which is hereby acknowledged by the Parties, the Parties agree that FPL shall relocate the FPL facilities and equipment and Applicant shall reimburse FPL for the actual cost of such relocation as follows:

**ARTICLE 1 – DEFINITIONS**

For the purposes of this Agreement the following terms, whether used in the singular or plural, shall have the meanings set forth below when used with capitalization:

- 1.1 Date Cost Estimate Received means the day that the cost estimate was hand-delivered or transmitted by facsimile, or if mailed, five (5) days from the date of postmark.
- 1.2 FPL Facilities means, but shall not be limited to, any structure consisting of manholes, conduits, poles, wires, cables, substations, system protection equipment or other appurtenances, and associated equipment, and used by FPL in connection with the transmission and/or distribution of electric power.
- 1.3 Relocation and/or Relocate means the work performed by FPL under this Agreement and any activity made necessary by Applicant's construction which conflicts with or affects FPL, any FPL Facilities, or service, including any work associated with the Transmission Line Clearance. Relocation shall include, but shall not be limited to, permanent or temporary support, protection, relocation, rearrangement, design, redesign, abandonment or reconstruction of the FPL Facilities and all other work required to provide continuity of service to FPL's customers which is a result of a conflict.
- 1.4 Replacement FPL Facilities means any FPL Facilities which will be constructed under the terms of this Agreement as a consequence of Relocation of any FPL Facilities or portion thereof.
- 1.5 Transmission Line Clearance (FPL Facilities de-energization) means a de-energization of FPL Facilities following a review performed by an FPL system operator to ensure the FPL Facilities de-energization does not compromise FPL's power system reliability.

**ARTICLE II - IDENTIFICATION OF CONFLICTS**

- 2.1 Known Conflicts. Applicant shall reimburse FPL for costs associated with the Relocation of the FPL Facilities more particularly described and located on the real property described on Exhibit A attached hereto and incorporated herein by this reference (“**Property**”).

2.2 Other Conflicts. The identification of any other conflicting FPL Facilities requiring Relocation shall be undertaken by FPL pursuant to a subsequent written agreement between FPL and Applicant.

### **ARTICLE III - DESIGN AND CONSTRUCTION OF REPLACEMENT FPL FACILITIES**

- 3.1 Design Standards. Engineering design standards and material specified shall meet FPL's current design standards. In addition, the design of the Relocation will be in conformity with all laws, codes and regulations.
- 3.2 Construction Standards. Materials and construction procedures shall meet FPL's current construction standards. In addition, any Relocation or Replacement FPL Facilities will be accomplished in conformance with all laws, codes and regulations.

### **ARTICLE IV - REPLACEMENT RIGHT-OF-WAY**

4.1 Replacement Right-of-Way. Applicant shall provide FPL with replacement rights-of-way in one of the following manners:

- (a) Applicant shall reimburse FPL for all costs associated with the identification and acquisition of replacement rights-of-way, including, but not limited to, FPL's attorney fees for costs in prosecuting or in connection with any condemnation actions for the acquisition of necessary rights-of-way.
- (b) Applicant shall convey or grant to FPL replacement rights-of-way sufficient to permit FPL to accomplish Relocation of the FPL Facilities and to operate and maintain the Replacement FPL Facilities in accordance with FPL's customary practices. Such conveyances or grants of replacement rights-of-way shall be accomplished at no cost to FPL and in form and substance satisfactory to FPL in its sole discretion.

4.2 Location of Replacement Right-of-Way. The location of the aforesaid replacement rights-of-way are generally set forth in Exhibit B attached hereto, and shall be within the Property where conflicts are identified due to the Relocation.

### **ARTICLE V - COST ESTIMATES, CREDITS AND BILLING**

- 5.1 Full Cost. Applicant shall pay FPL for the full cost of Relocation of the FPL Facilities. The Relocation work to be performed by FPL will be in accordance with the construction drawings attached hereto as Exhibit B.
- 5.2 Cost Estimate. Applicant shall be responsible for paying FPL 120% of the total cost estimate for the Relocation prior to FPL commencing any work hereunder. The estimated cost to Relocate the FPL Facilities is as below:

Relocation: \$836,620.94. This cost estimate is set out in detail in Exhibit C attached hereto.  
Additional 20% of the cost estimate: \$167,324.19.  
Engineering deposit received: \$154,180.00.  
Balance due: \$849,765.13.

Applicant to provide payment in full for this amount to FPL along with two (2) signed copies of this Agreement.

Applicant understands and agrees that the amount set forth in Exhibit C is an estimate only. Applicant shall be responsible for the total cost of the Relocation; provided, however, the cost for the Relocation shall not exceed 120% of a valid Relocation cost estimate based upon an actual labor bid, except as otherwise provided herein.

5.3 Duration of Cost Estimate.

The cost estimate referenced in Section 5.2 above is valid for ninety (90) days from the date the cost estimate is delivered to Applicant (this includes the cost estimate attached as Exhibit C and any subsequent cost estimate), subject to the terms and conditions set forth in Section 5.4 below.

5.4 Re-estimates, Scope of Work Changes, Transmission Line Clearance Cancellation.

5.4.1 Pre-construction. If the construction of the Relocation of the FPL Facilities has not commenced within one hundred eighty (180) days of the date that the latest cost estimate was delivered to Applicant, or if Applicant requests a change in the Relocation scope of work on any individual work order prior to FPL commencing any Relocation work construction, such cost estimate is invalid and a new cost estimate shall be required, whereupon FPL shall provide a re-estimate of the Relocation work prior to commencement of the Relocation by FPL. Applicant must agree in writing to pay the re-estimated cost and shall be responsible for the full cost of Relocation, not to exceed 120% of the re-estimate, except as expressly set forth otherwise herein.

5.4.2 After Start of Construction. If after FPL starts Relocation construction any of the following occurs: (a) Applicant requests a change in the Relocation scope of work of FPL Facilities; (b) FPL determines that there is a need for a change in the Relocation scope of work and such change causes the reimbursable cost of the Relocation to change by 20% or more; or (c) there is an increase in costs due to unknown or unforeseen physical conditions at the site which differ materially from those originally encountered; FPL shall provide Applicant with a new cost estimate as soon as practicable, and Applicant shall pay any increased costs in the revised cost estimate, plus 20% thereof, to FPL within thirty (30) days after receipt of the revised cost estimate.

5.4.3 Transmission Line Clearance Availability and/or Cancellation. Applicant understands and agrees that the Relocation requires the de-energization of FPL Facilities in order to perform the Relocation work hereunder. In the event the FPL system operator considers the FPL power system is at risk, then FPL, in FPL's sole discretion, may cancel, limit and/or reschedule the approved FPL Facilities de-energization at any time, whereupon Applicant, at Applicant's sole cost and expense, shall be responsible for the entire cost: (i) to compensate the line contractor at its stand by rate for a minimum of eight (8) crew hours per day for each day; and/or (ii) to demobilize its crew, until the new date the Transmission Line Clearance has been obtained and the FPL Facilities have been de-energized. Such transmission line clearance cancellation costs (or restriction for limited hours or night work) shall will be added to the total cost of the Relocation to be paid by Applicant, and shall not be subject to the limits set forth in Sections 5.4.1 and 5.4.2 above.

5.5 Credits.

5.5.1 Applicant shall receive a credit for the payment of any non-refundable deposit required for the design, engineering, and estimating of the Relocation of FPL Facilities (as set forth above in Section 5.2).

5.5.2 Applicant shall receive a credit for payment made to FPL hereunder, if payment is received by FPL prior to issuing a detailed cost estimate and if this Agreement has been entered into within ninety (90) days of the date that estimate was delivered to Applicant and the Relocation performed.

5.5.3 Applicant shall receive no credit for payment hereunder, and such payment shall not be refunded: (a) if Applicant has not executed this Agreement within ninety (90) days of the date a detailed cost estimate was received by Applicant, (b) if a subsequent cost estimate is required and not paid, plus an additional 20% of any increased cost thereof, within thirty (30) days of the date Applicant receives the new cost estimate; or (c) if Applicant terminates this Agreement.

5.5.4 Any cost estimate provided to Applicant after the initial detailed cost estimate shall be done at additional cost and expense to Applicant. Applicant's payment for cost estimates shall be credited or retained by FPL as provided above.

- 5.6 Billing and Payment. Prior to the commencement of any Relocation of FPL Facilities under this Agreement, Applicant shall pay in advance the full estimated cost of such Relocation per Sections 5.2 and 5.4.2 and 5.4.3 above.
- 5.7 Final Bill. Upon completion of the Relocation, FPL shall at the earliest date practicable furnish to Applicant a final billing of all outstanding costs, including any overhead costs, incurred in connection with performance of Relocation of the FPL Facilities less any prepaid credits for additional cost estimates. Applicant shall have thirty (30) days from the date of an invoice to approve and pay the invoice. Failure to provide FPL with written notice to the contrary within the thirty (30) day period shall constitute approval by Applicant of the invoice against which payment must be remitted in full to FPL within thirty (30) days of the date of the invoice. If payment by Applicant is not postmarked within thirty (30) days of the date of the invoice, then a late payment charge shall be assessed in the amount of one and one-half percent (1½%) of the amount of the billing per month, charged on a daily basis or highest interest allowable under law.
- 5.8 Refund and Effect of Termination.
- 5.8.1 Consistent with the terms of this Agreement, FPL shall refund to Applicant any amounts which Applicant has paid to FPL beyond the full cost of Relocation including any overhead costs.
- 5.8.2 In the event that this Agreement is terminated due to the cancellation or indefinite suspension of work in furtherance of Applicant's construction, Applicant shall be responsible for the costs of Relocation already incurred, including but not limited to all engineering, design, equipment, and materials cost, labor costs, and if any, the costs of Replacement FPL Facilities already installed, necessary to place any FPL Facilities into a permanent condition suitable to provide continuous, reliable electric service to the public in accordance with all applicable laws, regulations and FPL's usual practices as set forth in Article III herein. Nothing in this section shall be construed to modify or abrogate FPL's legal duty to mitigate damages.

#### **ARTICLE VI – INSPECTIONS**

- 6.0 Inspections. All cost records and accounts of FPL directly related to the Relocation work performed under this Agreement shall be subject to inspection by Applicant for a period of one (1) year from the completion date of all Relocation work performed under this Agreement. Such inspections shall be performed by Applicant and in accordance with the following considerations:
- (a) Applicant shall provide FPL with thirty (30) days written notice requesting an inspection;
  - (b) The specific time of inspection must be mutually agreed to;
  - (c) Information required for inspection purposes shall be accounts and records kept by FPL directly related to Relocation and reimbursable costs;
  - (d) Applicant may request only information reasonably required by it concerning Relocation and such request for information shall be in writing and shall include the purpose of the inspection;
  - (e) FPL shall make available the requested information at its offices during normal business hours, Monday through Friday;
  - (f) Applicant shall bear any costs associated with any inspections, including FPL costs, if any; and
  - (g) Information available under this Agreement shall not be used in violation of any law or regulation.
- FPL shall quote a deposit amount when such a request for inspection is made which Applicant shall pay in advance.

#### **ARTICLE VII - GENERAL CONDITIONS**

- 7.1 Benefit of Agreement: Assignment. The provisions of this Agreement shall inure to the benefit of and bind the successors and assigns of the Parties to this Agreement but shall not inure to the benefit of any third party or other person. This Agreement shall not be assigned by either Party except upon receipt of the prior written permission of the other Party. Such permission shall not be unreasonably withheld.

- 7.2 Non-waiver. The failure of either Party at any time to require performance by the other Party of any provision hereof shall not affect the full right to require such performance at any time thereafter. Waiver by either Party of a breach of the same provision or any other provision shall not constitute a waiver of the provision itself.
- 7.3 Limitations of Liability. Neither Party shall be liable in contract, in tort (including negligence), or otherwise to the other Party for any incidental or consequential loss or damage whatsoever including but not limited to loss of profits or revenue on work not performed, for loss of use or underutilization of the Party's facilities, or loss of use of revenues or loss of anticipated profits resulting from either Party's performance, nonperformance, or delay in performance of its obligations under this Agreement.
- 7.4 Indemnification. Applicant shall indemnify, defend and hold harmless FPL, its parent, subsidiaries or affiliates and their respective officers, directors and employees (collectively "**FPL Entities**") from and against any liabilities whatsoever, occasioned wholly or in part by the negligence of Applicant, its contractors, subcontractors or employees, including attorney fees, for injury to or death of person(s) and property damage arising or resulting in connection with any activity associated with work or service under this Agreement. If the liability arises out of a claim made by an employee of Applicant, its contractors or assigns, Applicant shall indemnify FPL Entities whether or not the damage or liability is due to or caused by the sole negligence of FPL Entities. Applicant's obligation to protect, defend and hold FPL Entities free and unharmed against such liabilities shall extend up to, but shall not exceed the sum of \$3,000,000 combined single limit for injuries to or death of person(s) or damage to existing property arising out of a single occurrence, except in the event Applicant is insured for liability with limits in excess of \$3,000,000 combined single limit for injuries to or death of person(s) or property arising out of a single occurrence, Applicant's said obligations shall extend up to but shall not exceed the limits of that insurance. Applicant's costs of defending FPL Entities, including Applicant's attorneys' fees, are excluded from and are in addition to the aforesaid limitation of liability for injury, death and property damage.
- 7.5 Insurance. If Applicant utilizes its own personnel in the construction or maintenance work around the FPL Facilities, Applicant shall furnish FPL with evidence of insurance maintained by Applicant insuring FPL Entities from liabilities assumed under the above indemnification. Said insurance shall contain a broad form contractual endorsement or, alternatively, Applicant shall cause FPL, its parent, subsidiaries and affiliates and their respective officers, directors and employees to be named as additional named insured on Applicant's comprehensive general liability policy. Such liability coverage shall be primary to any liability coverage maintained by or on behalf of FPL up to the \$3,000,000 limit of liability.

In the event that the policy is on a "claims made" basis, the retroactive date of the policy shall be the effective date of this Agreement or such other date as to protect the interest of FPL and the coverage shall survive the termination of this Agreement until the expiration of the maximum statutory period of limitations in the State of Florida for actions based in contract or in tort (currently, five years). If coverage is on an "occurrence" basis, such insurance shall be maintained by Applicant during the entire term of this Agreement. The policy shall not be canceled or materially altered without at least thirty (30) days written notice to FPL.

Applicant shall provide FPL with evidence of such liability insurance coverage on the standard insurance industry form (ACORD) without modification. A copy of the policy shall be made available for inspection by FPL upon reasonable request.

- 7.6 Contractor Indemnification. Applicant further agrees to include the following indemnification in all contracts between Applicant and its general contractors who perform or are responsible for construction or maintenance work on or around the subject FPL Facilities:

"The Contractor hereby agrees to release, indemnify, defend, save and hold harmless Applicant and FPL, its parent, subsidiaries, affiliates or their respective officers, directors, or employees, from all claims, demands, liabilities and suits whether or not due to or caused by negligence of Applicant or FPL for bodily injuries or death to person(s) or damage to property resulting in connection with the performance of the described work by Contractor, its subcontractor, agents or employees. This indemnification shall extend

up to but shall not exceed the sum of \$3,000,000.00 for bodily injury or death of person(s) or property damage combined single limit and \$5,000,000 occurrence aggregate. In the event the Contractor is insured for liability with limits in excess of these amounts, Contractor's said obligation shall extend up to but shall not exceed the limits of that insurance. Contractor's costs of defending Applicant and FPL, including attorneys' fees are excluded from and are in addition to the aforesaid limitation of liability for injury, death and property damage."

- 7.7 Contractor Insurance and Notice. Applicant agrees to require its contractors to obtain insurance to cover the above indemnity and further agrees to verify with its contractors that such insurance is in full force and effect. Applicant shall provide FPL's Risk Management Department with notice of the name and address of Applicant's contractors as specified in Section 7.6 above, prior to the commencement of the Relocation of FPL Facilities by FPL.
- 7.8 Modification or Termination of Agreement. This Agreement may be modified, amended, or terminated at any time by written agreement of the Parties authorized and executed with the same formality as this Agreement.
- 7.9 Effect of Headings. The headings set forth herein are for convenience only and shall not be deemed to modify or affect the rights and obligations of the Parties to this Agreement.
- 7.10 FPL Consent to Relocations. FPL agrees to the Relocation of the FPL Facilities to the extent necessary to eliminate conflicts with Applicant's construction in accordance with the terms and conditions of this Agreement. Applicant, at no expense to FPL, shall make all necessary arrangements and agreements with any person or entity which has facilities attached to the FPL poles for the relocation of those facilities.
- 7.11 Delegation of Power and Duties Notice. The following persons are designated as the authorized representatives of the Parties for the purposes of this Agreement and all notices or other communications to either Party by the other shall be made in writing and addressed as follows:

To Applicant: \_\_\_\_\_  
(Name and Title)  
\_\_\_\_\_  
\_\_\_\_\_

With Copies to: \_\_\_\_\_  
\_\_\_\_\_  
\_\_\_\_\_

To FPL: Jose Coto  
General Manager of Engineering  
Florida Power & Light Company  
700 Universe Boulevard, TS3/JW  
Juno Beach, FL 33408

7.12 Notification of FPL Facilities, Form 360. Applicant acknowledges that high voltage electric lines are located in the area of Applicant's project and agrees to warn its employees, agents, contractors and invitees, new and experienced alike, of the danger of holding on to or touching a cable or other piece of equipment that is located or working close to any overhead power line and to use all safety and precautionary measures when working under or near FPL Facilities. Applicant acknowledges and agrees that he has read and will comply with the Notification of FPL Facilities attached hereto. Applicant shall sign and return two (2) copies of the attached Notification of FPL Facilities along with two (2) signed copies of this Agreement.



7.13 Force Majeure.

- (a) Neither Party shall be liable or responsible for any delay in the performance of, or the ability to perform, any duty or obligation required by this Agreement in the event of a Force Majeure occurrence. Such occurrence shall include, but shall not be limited to acts of civil or military authority (including courts or administrative agencies), acts of God, war, riot, or insurrection, inability to obtain required permits or licenses, blockades, embargoes, sabotage, epidemics, fires, unusually severe floods or weather (anywhere in the United States where FPL utility workers and contractors support restoration), strikes, lockouts or other labor disputes or difficulties. The obligation of either Party to pay money in a timely manner is absolute and shall not be subject to the Force Majeure provisions. "**Force Majeure**" as used herein means, without limitation, any cause or event not reasonably within the control of FPL or Applicant.
- (b) In the event of any delay resulting from a Force Majeure circumstance, the time for performance hereunder shall be extended for a period of time reasonably necessary to overcome the effect of such delays.
- (c) In the event of any delay or nonperformance caused by a Force Majeure circumstance, the Party affected shall promptly notify the other in writing.

7.14 Severability. In the event that any of the provisions or portions or applications thereof of this Agreement are held to be unenforceable or invalid by any court of competent jurisdiction, Applicant and FPL shall negotiate an equitable adjustment in the affected provisions of this Agreement. The validity and enforceability of the remaining independent provisions shall not be affected.

7.15 Effective Date. This Agreement shall become effective upon execution by the Parties and shall continue in effect until completion of all Relocation work by FPL unless otherwise provided herein or earlier termination in accordance with this Agreement.

7.16 Complete Agreement. This Agreement shall be signed by the authorized representatives of both Parties and constitutes the final written expression of all the terms of the agreement between the Parties and is a complete and exclusive statement of those terms. Any and all prior or contemporaneous course of dealing, representations, promises, warranties or statements by the Parties or their agents, employees, or representatives that differ in any way from the terms of this written Agreement shall be given no force or effect.

[Signatures appear on following page.]

IN WITNESS WHEREOF, the Parties have executed this Agreement, to be effective as of the date first above written.

APPLICANT:

FLORIDA POWER & LIGHT COMPANY:

\_\_\_\_\_  
\_\_\_\_\_  
By: \_\_\_\_\_  
Title: \_\_\_\_\_  
Date: \_\_\_\_\_  
Attest: \_\_\_\_\_  
\_\_\_\_\_(Seal) Title

\_\_\_\_\_  
By: Jose Coto.  
Title: General Manager of Engineering  
Date: \_\_\_\_\_



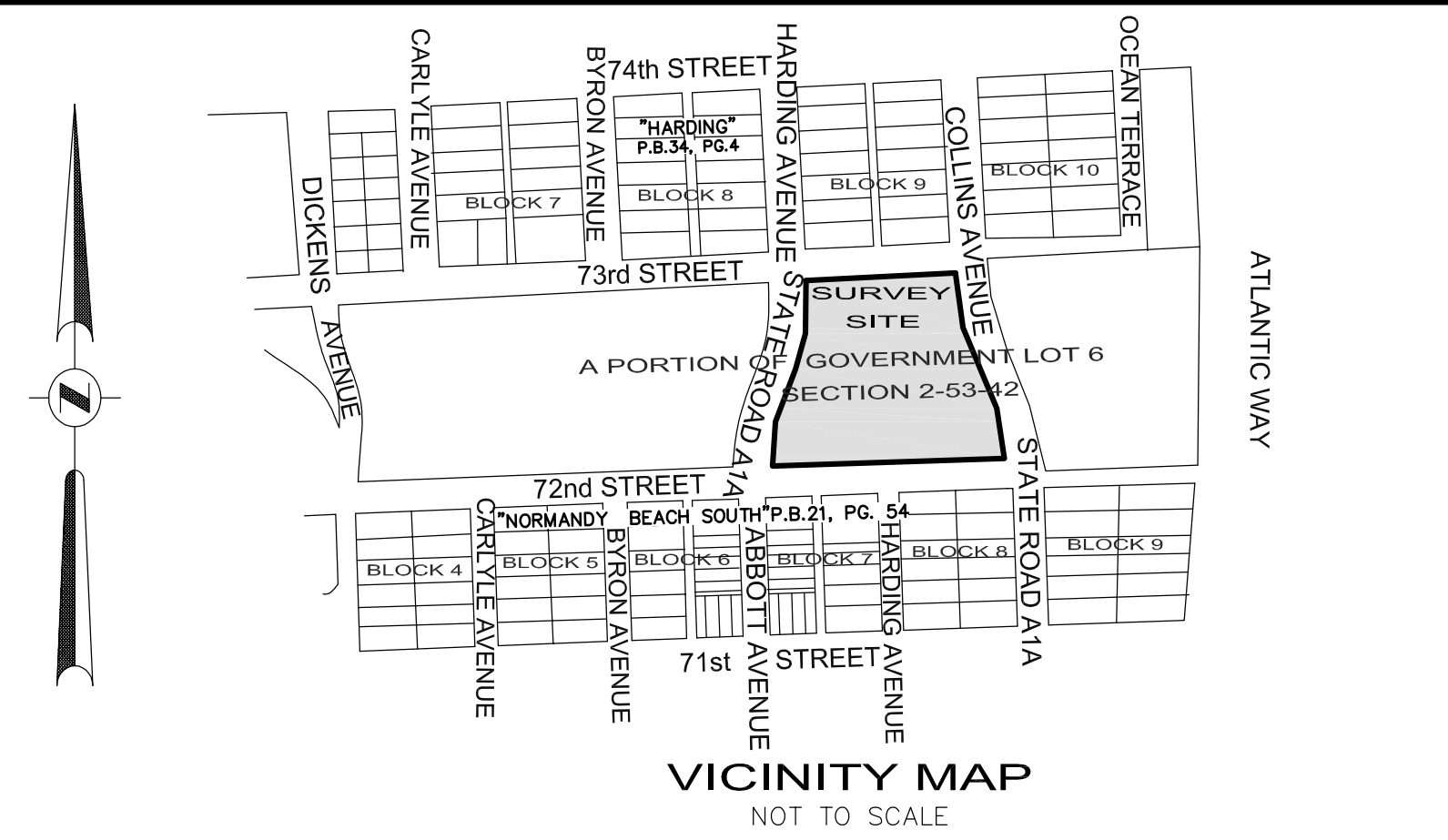
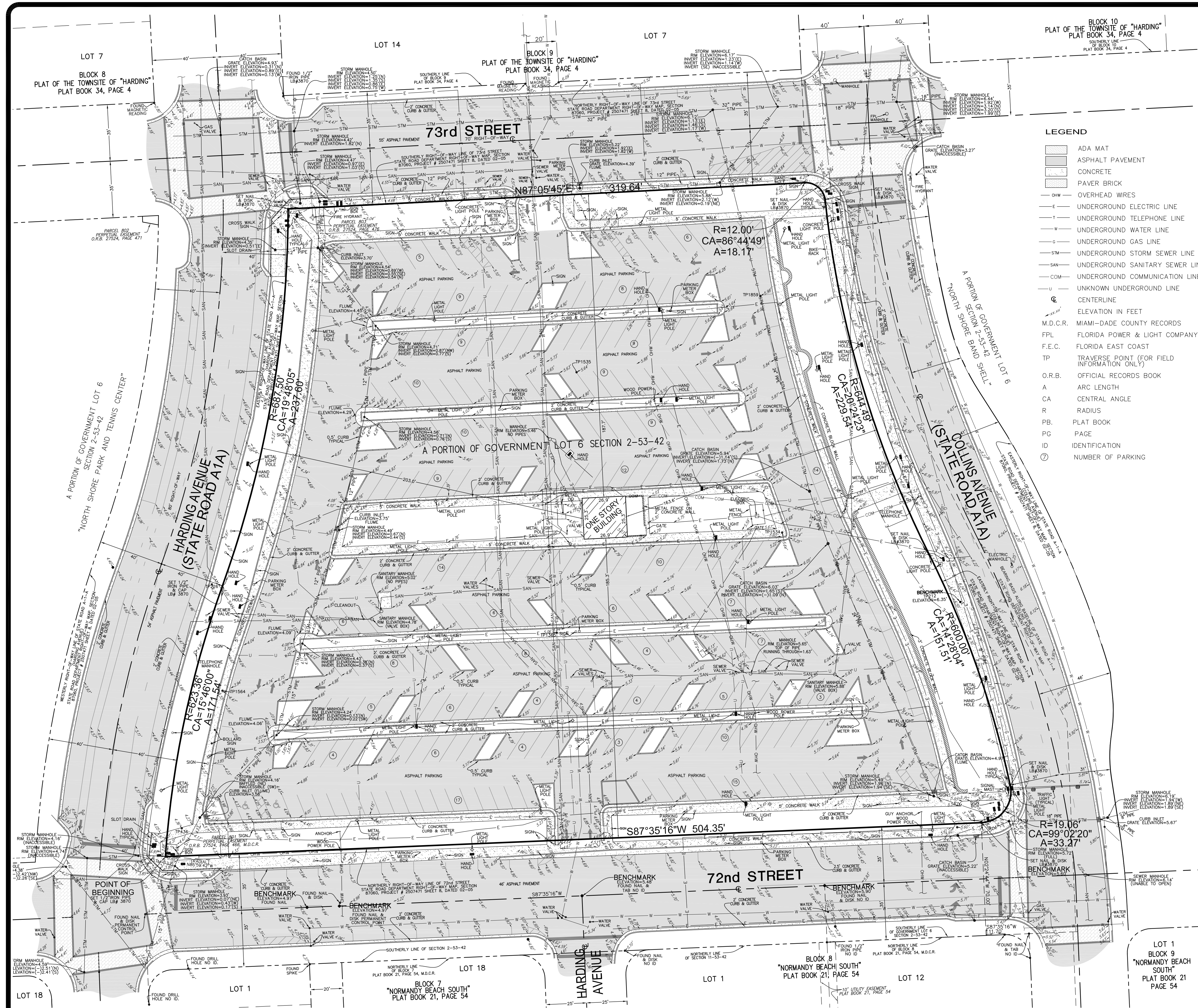

- LEGEND**
- ADA MAT
  - ASPHALT PAVEMENT
  - CONCRETE
  - PAVER BRICK
  - OVERHEAD WIRES
  - UNDERGROUND ELECTRIC LINE
  - UNDERGROUND TELEPHONE LINE
  - UNDERGROUND WATER LINE
  - UNDERGROUND GAS LINE
  - UNDERGROUND STORM SEWER LINE
  - UNDERGROUND SANITARY SEWER LINE
  - COM — UNDERGROUND COMMUNICATION LINE
  - UNKNOWN UNDERGROUND LINE
  - CENTERLINE
  - ELEVATION IN FEET
  - M.D.C.R. MIAMI-DADE COUNTY RECORDS
  - FPL FLORIDA POWER & LIGHT COMPANY
  - F.E.C. FLORIDA EAST COAST
  - TP TRAVERSE POINT (FOR FIELD INFORMATION ONLY)
  - O.R.B. OFFICIAL RECORDS BOOK
  - A ARC LENGTH
  - CA CENTRAL ANGLE
  - R RADIUS
  - PB. PLAT BOOK
  - PG. PAGE
  - ID IDENTIFICATION
  - ⑦ NUMBER OF PARKING

**LEGAL DESCRIPTION:**  
 A PORTION OF GOVERNMENT LOT 6, SECTION 2, TOWNSHIP 53 SOUTH, RANGE 42 EAST, MIAMI-DADE COUNTY, FLORIDA, BEING MORE PARTICULARLY DESCRIBED AS FOLLOWS:  
 BEGINNING AT THE POINT OF INTERSECTION OF THE EASTERLY RIGHT-OF-WAY LINE OF HARDING AVENUE (STATE ROAD A1A) WITH THE NORTHERLY RIGHT-OF-WAY LINE OF 72nd STREET; SAID NORTHERLY RIGHT-OF-WAY LINE BEING PARALLEL TO AND 70.00 FEET NORTHERLY OF, AS MEASURED AT RIGHT ANGLE TO, THE SOUTH LINE OF AFORESAID GOVERNMENT LOT 6, AS SHOWN ON THE FLORIDA DEPARTMENT OF TRANSPORTATION RIGHT-OF-WAY MAP, SECTION 87060, PROJECT NUMBER 2507471, SAID POINT BEING A POINT ON THE ARC OF A CIRCULAR CURVE CONCAVE EASTERLY TO WHICH A RADIAL LINE BEARS NORTH 85°59'42" WEST; THENCE NORTHERLY ON SAID EASTERLY RIGHT-OF-WAY LINE AND ON THE ARC SAID CURVE TO THE RIGHT, HAVING A RADIUS OF 623.36 FEET, A CENTRAL ANGLE 15°46'00", FOR AN ARC DISTANCE OF 171.54 FEET TO A POINT OF REVERSE CURVATURE OF A CIRCULAR CURVE CONCAVE WESTERLY; THENCE NORTHERLY, CONTINUING ON SAID EASTERLY RIGHT-OF-WAY LINE AND ON THE ARC OF SAID CURVE TO THE LEFT, HAVING A RADIUS OF 687.50 FEET, A CENTRAL ANGLE 19°48'05", FOR AN ARC DISTANCE OF 237.60 FEET TO INTERSECTION WITH THE SOUTHERLY RIGHT-OF-WAY LINE OF 73rd STREET; THENCE NORTH 87°05'45" EAST ON SAID SOUTHERLY RIGHT-OF-WAY LINE 319.61 FEET TO THE BEGINNING OF A TANGENT CIRCULAR CURVE CONCAVE SOUTHWESTERLY; THENCE SOUTHEASTERLY ON THE ARC OF SAID CURVE TO THE RIGHT HAVING A RADIUS OF 12.00 FEET, A CENTRAL ANGLE 86°44'49", FOR AN ARC DISTANCE OF 18.17 FEET TO A POINT OF REVERSE CURVATURE OF CIRCULAR CURVE CONCAVE NORTHEASTERLY ON THE WESTERLY RIGHT-OF-WAY LINE OF COLLINS AVENUE (STATE ROAD A1A) AS SHOWN ON SAID RIGHT-OF-WAY MAP; THENCE SOUTHEASTERLY ON SAID RIGHT-OF-WAY LINE AND ON THE ARC OF SAID CURVE TO THE LEFT, HAVING A RADIUS OF 644.49 FEET, A CENTRAL ANGLE 20°24'23", FOR AN ARC DISTANCE OF 229.54 FEET TO A POINT OF REVERSE CURVATURE OF CIRCULAR CURVE CONCAVE SOUTHWESTERLY; THENCE SOUTHERLY CONTINUING ON SAID RIGHT-OF-WAY LINE AND ON THE ARC OF SAID CURVE TO THE RIGHT HAVING A RADIUS OF 600.00 FEET, A CENTRAL ANGLE 14°28'04", FOR AN ARC DISTANCE OF 151.51 FEET TO A POINT OF COMPOUND CURVATURE OF A CIRCULAR CURVE CONCAVE NORTHWESTERLY; THENCE SOUTHWESTERLY ON THE ARC OF SAID CURVE TO THE RIGHT, HAVING A RADIUS OF 19.06 FEET, A CENTRAL ANGLE 99°02'20", FOR AN ARC DISTANCE OF 33.27 FEET TO A POINT OF TANGENCY ON THE OF AFOREMENTIONED NORTHERLY RIGHT-OF-WAY LINE OF 72nd STREET; SOUTH 87°35'16" WEST ON SAID NORTHERLY RIGHT-OF-WAY LINE 504.35 FEET TO THE POINT OF BEGINNING.  
 SAID LANDS SITUATE, LYING AND BEING IN THE CITY OF MIAMI-BEACH, MIAMI-DADE COUNTY, FLORIDA.

- NOTES:**
- 1) THIS SITE CONTAINS 167,045 SQUARE FEET (3.8348 ACRES) MORE OR LESS.
  - 2) ELEVATIONS ARE BASED ON NORTH AMERICAN VERTICAL DATUM OF 1988 BROWARD COUNTY BENCHMARK USGS G313; ELEVATION: 6.72 FEET.
  - 3) FLOOD ZONE: AE; BASE FLOOD ELEVATION: 8 FEET; PANEL #120651 0326; MAP DATE: 9/11/09.
  - 4) THIS SITE LIES IN SECTION 2, TOWNSHIP 53 SOUTH, RANGE 42 EAST, MIAMI-DADE COUNTY, FLORIDA.
  - 5) BEARINGS ARE BASED ON THE CENTER LINE OF 72nd STREET BEING N87°35'16"E.
  - 6) REASONABLE EFFORTS WERE MADE REGARDING THE EXISTENCE AND THE LOCATION OF UNDERGROUND UTILITIES. THIS FIRM, HOWEVER, DOES NOT ACCEPT RESPONSIBILITY FOR THIS INFORMATION. BEFORE EXCAVATION OR CONSTRUCTION CONTACT THE APPROPRIATE UTILITY COMPANIES FOR FIELD VERIFICATION.
  - 7) THIS SURVEY IS CERTIFIED EXCLUSIVELY TO: DESMAN, INC.
  - 8) THE HORIZONTAL POSITIONAL ACCURACY OF WELL DEFINED IMPROVEMENTS ON THIS SURVEY IS ±0.2'; THE VERTICAL ACCURACY OF ELEVATIONS OF WELL DEFINED IMPROVEMENTS ON THIS SURVEY IS ±0.1'.
  - 9) THIS SITE CONTAINS 281 TOTAL PARKING SPACES (273 REGULAR & 8 DISABLED).
  - 10) THIS SURVEY WAS PREPARED WITHOUT BENEFIT OF A COMMITMENT FOR TITLE INSURANCE. ONLY PLATTED OR KNOWN EASEMENTS ARE DEPICTED HEREON.
  - 11) THE UTILITY LINES DEPICTED HEREON ARE DRAWN FROM UTILITY PLANS PROVIDED BY CLIENT AND FROM UNDERGROUND LOCATIONS PERFORMED BY BLOODHOUND ON 5/16/19.

**CERTIFICATION:**  
 I HEREBY CERTIFY: THAT THIS SKETCH OF SURVEY MEETS THE STANDARDS OF PRACTICE SET FORTH BY THE FLORIDA DEPARTMENT OF AGRICULTURE AND CONSUMER SERVICES ("DOACS") CHAPTER 5J-17, FLORIDA ADMINISTRATIVE CODE, PURSUANT TO SECTION 472.027, FLORIDA STATUTES.

NOT VALID WITHOUT THE SIGNATURE AND THE ORIGINAL RAISED SEAL OF A FLORIDA LICENSED SURVEYOR AND MAPPER.

- JOHN F. PULICE, PROFESSIONAL SURVEYOR AND MAPPER LS2691
  - BETH BURNS, PROFESSIONAL SURVEYOR AND MAPPER LS6136
  - VICTOR R. GILBERT, PROFESSIONAL SURVEYOR AND MAPPER LS6274
- STATE OF FLORIDA

NO.	REVISIONS	BY
1	ADD DRAINAGE & SEWER INVERTS	L.S.
2	ADD UNDERGROUND LOCATIONS - 5/20/19	L.S.
3	#83590 - ORIGINAL SURVEY - 11/30/17	M.D.

**PARKING LOT 92**  
 7251 COLLINS AVENUE, MIAMI BEACH, FLORIDA 33141

**BOUNDARY AND TOPOGRAPHIC SURVEY**

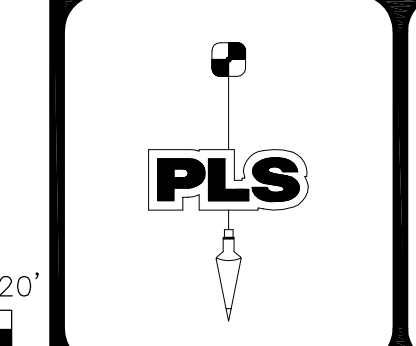

**POLICE LAND SURVEYORS, INC.**  
 5381 NOB HILL ROAD  
 SUNRISE, FLORIDA 33351  
 TELEPHONE: (954) 572-1777  
 FAX: (954) 572-1778  
 E-MAIL: surveys@policeandsurveyors.com  
 WEBSITE: www.policeandsurveyors.com  
 CERTIFICATE OF AUTHORIZATION LB#3870

DRAWN BY: M.D.  
 CHECKED BY: J.F.P.

SCALE: 1" = 30'  
 SURVEY DATE: 11/30/17

FILE: DESMAN, INC.  
 ORDER NO.: 65996

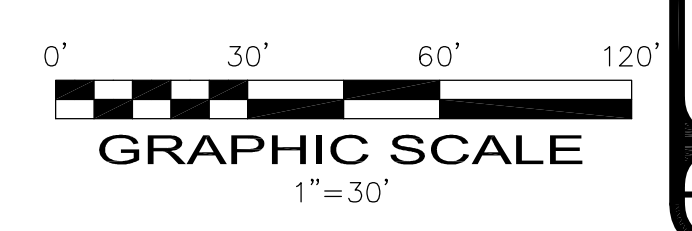

COPYRIGHT 2019 BY POLICE LAND SURVEYORS, INC. ALL RIGHTS RESERVED. NO PART OF THIS SURVEY MAY BE REPRODUCED, IN ANY FORM OR BY ANY MEANS, WITHOUT PERMISSION IN WRITING FROM AN OFFICER OF POLICE LAND SURVEYORS, INC.



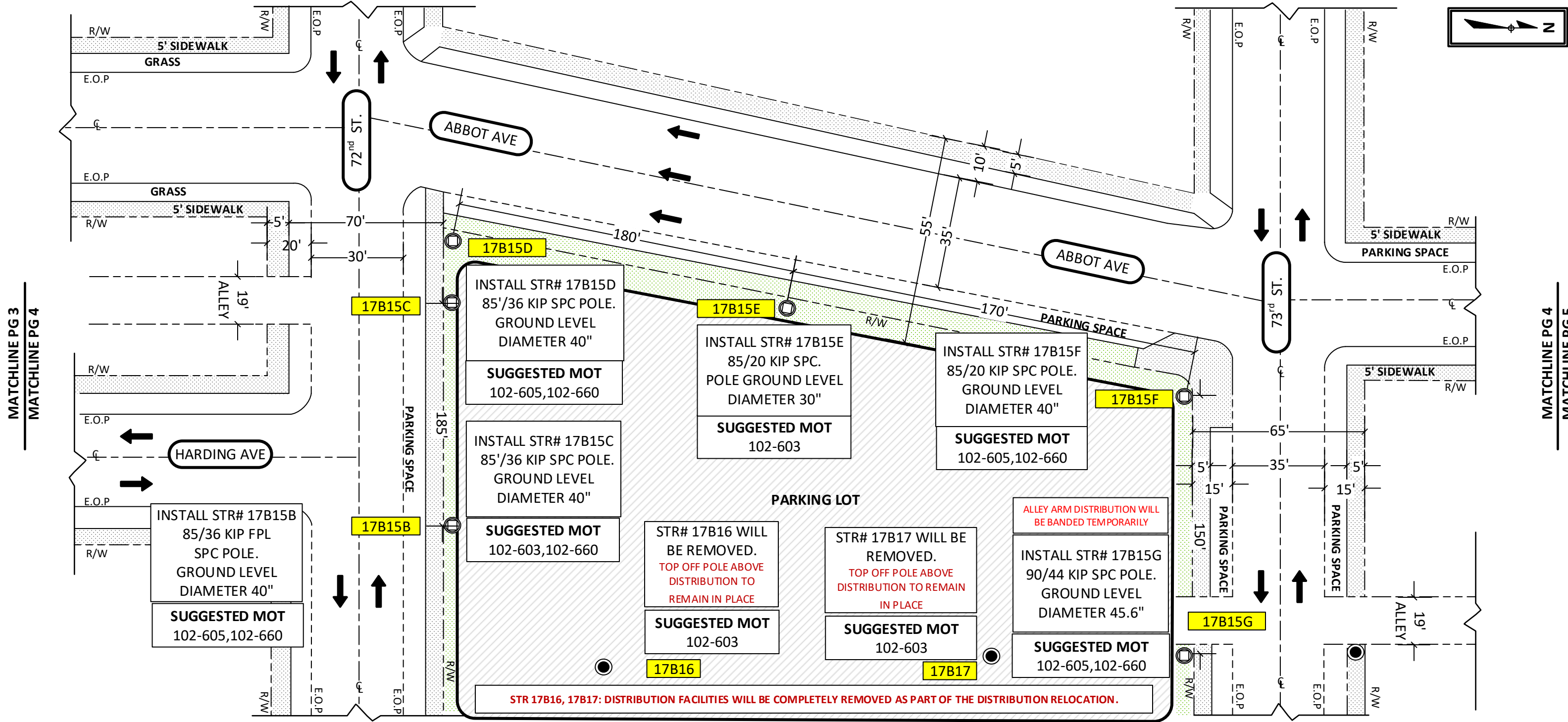

**NOTE: ALL STUB POLES, SPAN GUYS AND ANCHORS TO BE REMOVED WHERE APPLICABLE.**

**NOTE: UNDERGROUND UTILITIES WILL BE LOCATED PRIOR TO CONSTRUCTION**

LEGEND	
R/W	RIGHT-OF-WAY
E.O.P.	EDGE OF PAVEMENT
CL	CENTER LINE
⊙	PROPOSED TX SPUN CONCRETE POLE
●	EXISTING TX SPUN CONCRETE POLE
■	EXISTING TX CONCRETE POLE
⊙	EXISTING TX WOOD POLE
⊙	ANCHOR
-S-	SPAN GUY WIRE
---	CENTER LINE OF ROAD
↔	TRANSMISSION LINE
← →	NEW CONDUCTOR LINE
●	EXISTING DISTRIBUTION WOOD POLE

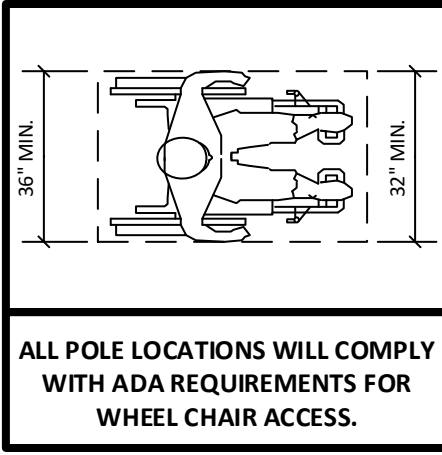

LOCATION/CITY: MIAMI BEACH					
PERMIT REQ'D	CITY R/W	COUNTY R/W	FDEP	FDOT	FAA
	SFWMD	RR XING	DR DIST.	ACOE	DERM
<input checked="" type="checkbox"/>	69kV	<input type="checkbox"/> 115kV	<input type="checkbox"/> 138kV		
<input type="checkbox"/>	230kV	<input type="checkbox"/> 500kV	<input type="checkbox"/> CONTAMINATION		

<b>FPL</b>	<b>IO#: T00000022308</b>
COUNTY: MIAMI-DADE	
LINE NAME: INDIAN CREEK-NORMANDY BEACH 69 KV	
SECTION NAME:	
SCOPE:	REPLACE 12 WOOD STR WITH SINGLE SPC POLES REMOVE 2 STRs INSTALL 7 NEW STRS SPC POLES
ENG. ROBERTO CRUZ	DATE: 3/13/2020
SCALE: N.T.S.	DRAWN BY: D. CAMACHO
DWG # 1 OF 1	