



**1570 Alton Road
Miami, FLORIDA
Signage Package**

**REVOCABLE
SIGN PERMIT
12/03/2019**

#everbetterplaces



CONTEXT LOCATION PLAN

1570 ALTON ROAD, FLORIDA – REVOCABLE SIGN PERMIT – DECEMBER 3, 2019

ENTERPRISE REAL ESTATE
ARCHITECTURE + DESIGN



LEGEND

1. Firestone
2. McDonalds
3. Dunkin Donuts
4. AT&T
5. Bodega Taqueria y Tequila
6. Sherwin Williams Paint Store
7. UPS Store
8. Sally Beauty Salon
9. Eco Deco Pet Hospital
10. Abbey Brewing Company
11. FedEx Office
12. Lincoln Center
13. Wells Fargo
14. Colony Theatre

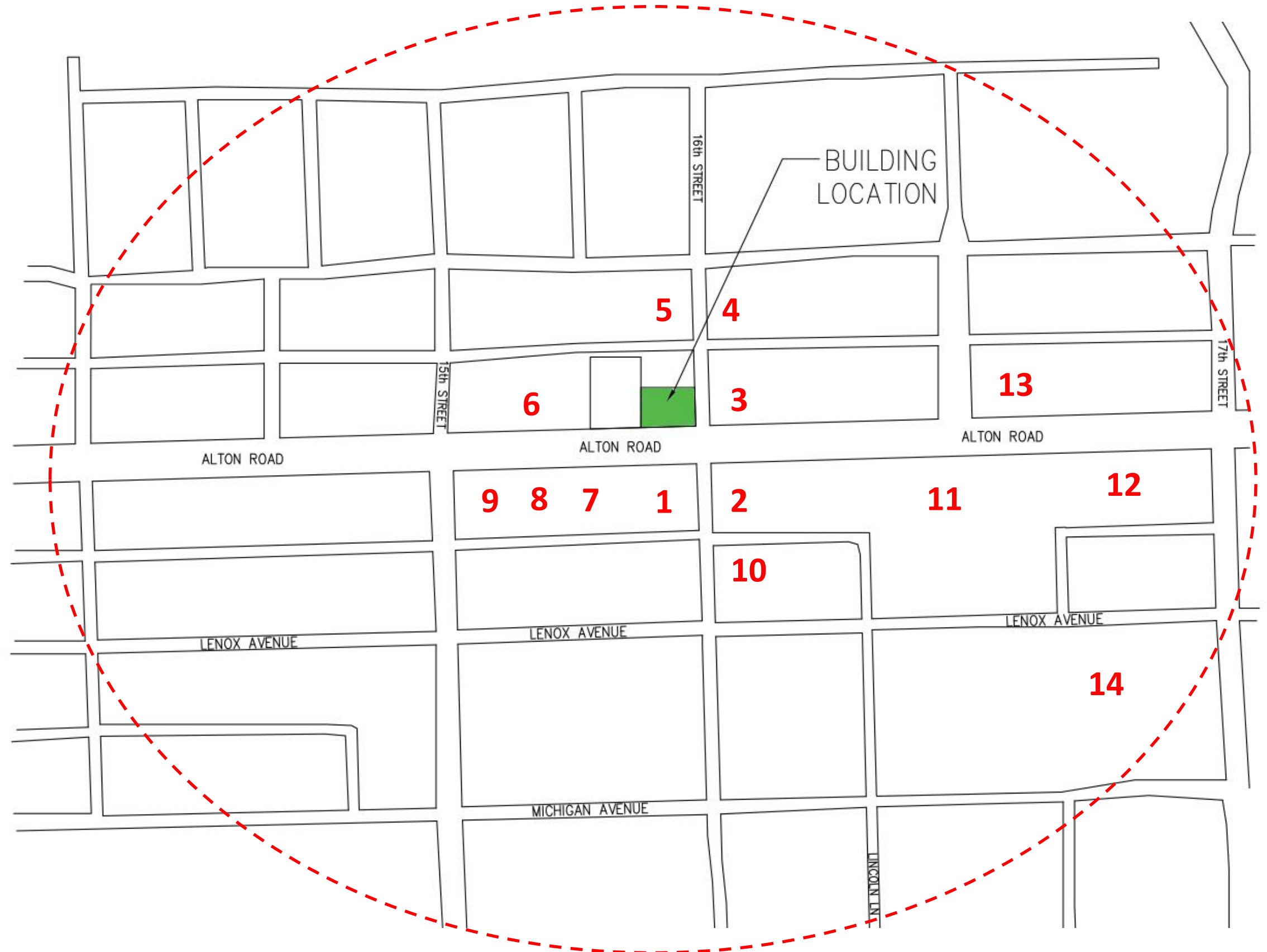

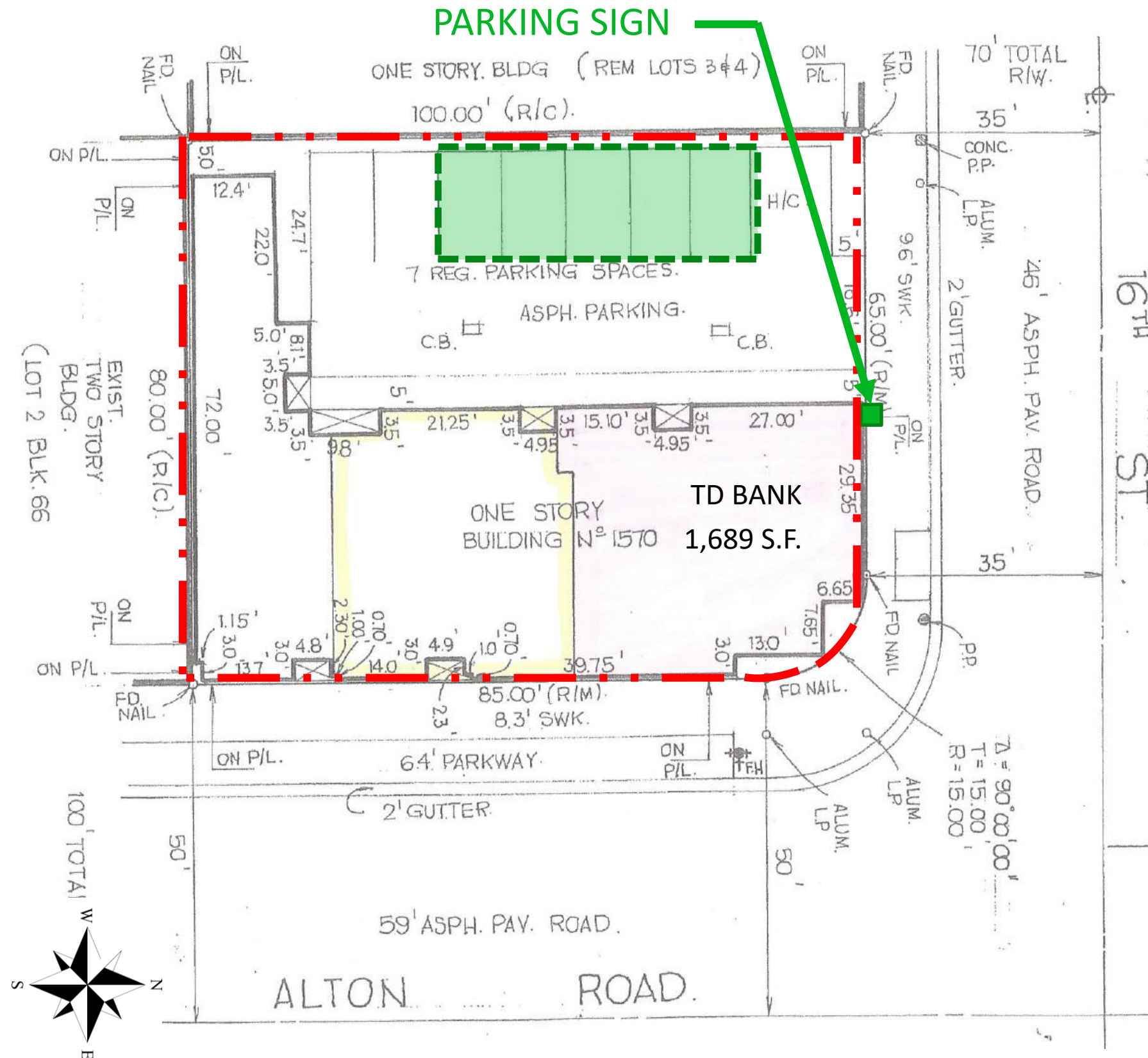

SIGN DETAILS

1570 ALTON ROAD, FLORIDA – REVOCABLE SIGN PERMIT – DECEMBER 3, 2019

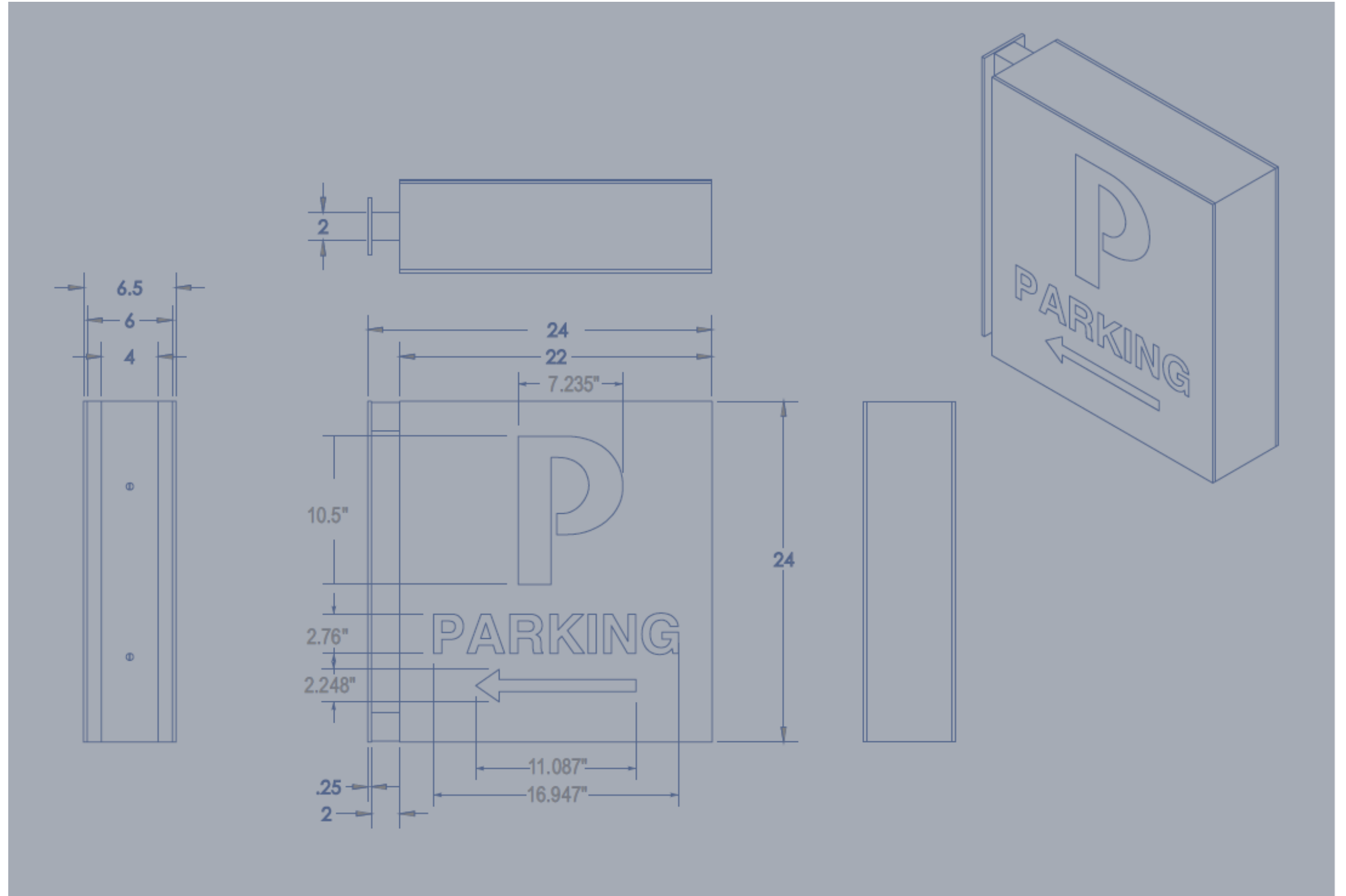

NOTE: ALL DIMENSIONS ARE IN INCHES