



January 3<sup>rd</sup>, 2019

ATTN: Luis Soto, P.E.,  
City Engineer  
City of Miami Beach, Public Works Department

Sent Via: Email  
LuisSoto@miamibeachfl.gov

Re: West Ave Bridge Project & Dade Reconstruction, Miami Beach  
BLD Job No. 645  
**Change Order: Pedestrian Bridge & Lincoln Ct Access Ramps -FINAL**

Dear Mr. Soto,

Per our conference call on December 21<sup>st</sup> and further discussions which followed, please refer to the REVISED proposal on page 2 for the services requested, and page 3 for General Notes and Exclusions.

Sincerely  
**BERGERON LAND DEVELOPMENT, INC.**

Yandy Fuentes  
Project Manager

Attachments: Exhibits A, B, & C.

cc: Brian Thomason, Daniel Irion, Giancarlo Peña, Eric Carpenter

**Bergeron Land Development Inc.**  
19612 SW 69<sup>th</sup> Place  
Ft. Lauderdale, FL 33332  
Phone: (954) 680-6100

Description	Quantity	UoM	Unit Price	Total
<u>Gatorbridge - additional work</u>				
Powder Coating - Grey	1	LS	\$32,500.00	\$32,500.00
Panels & Engineering Design (additional panels & design, review & stamping fees)	1	LS	\$54,500.00	\$54,500.00
<u>Ballarena - south ramp</u>				
Mobilization	1	LS	\$5,000.00	\$5,000.00
M.O.T. (device & installation), exclude drawings & permits	1	LS	\$1,500.00	\$1,500.00
Clearing & Grubbing	1	LS	\$2,800.00	\$2,800.00
Embankment (backfill on ramps)	1	LS	\$3,500.00	\$3,500.00
Concrete Class NS, Gravity Wall	187	LF	\$240.00	\$44,880.00
4" Sidewalks	68	SY	\$45.00	\$3,060.00
Type F-Curb Gutter	53	LF	\$44.64	\$2,366.04
Manhole Adjustment	1	EA	\$3,500.00	\$3,500.00
Inlet P-9	2	EA	\$7,500.00	\$15,000.00
Pipe Culvert, HDPE Material, Round, 18" S/CD	54.00	LF	\$180.00	\$9,720.00
Grass Area (exclude irrigation), including 4" top soil - minimum of 100 SY	100	SY	\$25.00	\$2,500.00
<u>Moz Designs, Inc.</u>				
LaserCut Bubbles Dbl Sided No grain Grey Powder Coat	30	EA	\$960.00	\$28,800.00
Crating & Handling	1	LS	\$575.00	\$575.00
Ground Shipping - Standard Delivery to 33139	1	LS	\$1,500.00	\$1,500.00
<u>Keith &amp; Schnars - design</u>				
Lincoln Ct Access Ramps Redesign Fees	1	LS	\$26,780.00	\$26,780.00
<u>Bergeron Land Development</u>				
Unforeseen Conditions (i.e. harmonization, ramp panels welding, QC, pavement markings)	1	LS	\$60,000.00	\$60,000.00
Mobilization & Demobilization	1	LS	\$22,567.00	\$22,567.00
Panels & Engineering Design (Original Design before DRB Meeting)	1	LS	\$47,433.00	\$47,433.00
<u>Original Pedestrian Bridge</u>				
Precast Arch Fascia Deduct	1	LS	-\$70,000.00	-\$70,000.00
<u>Giralt Enterprises</u>				
Aluminum Handrail - Index 862	208.43	LF	\$49.60	\$10,338.13

Subtotal: \$308,819.17

Bergeron 15% M/U: \$46,322.88

**Total: \$355,142.04**

**Bergeron Land Development Inc.**  
19612 SW 69<sup>th</sup> Place  
Ft. Lauderdale, FL 33332  
Phone: (954) 680-6100

**General Notes:**

*\*Gatorbridge pricing is based on latest round of comments made by DRB as communicated by the city on 10/11/18. Exhibit B and detailed in Exhibit C.*

*\*This proposal does not include lighting for the Pedestrian Bridge or Access Ramps due to insufficient information at the time of submittal. No plans or details.*

*\*Laser cut panels are produced to size and cannot be cut once produced.*

*\*Lead time for panels are 4-6 weeks plus transit time*

**Excluded:**

Permits

# EXHIBIT A

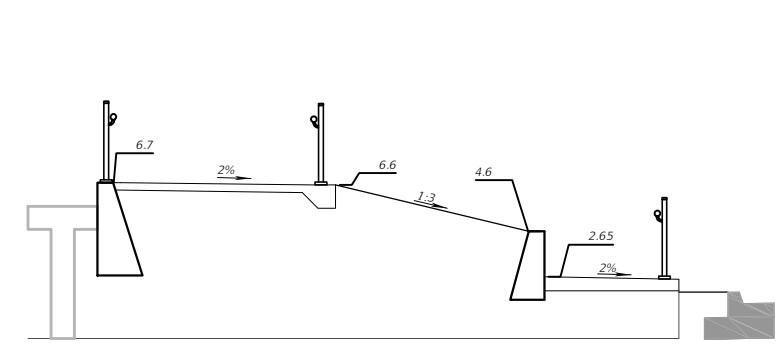
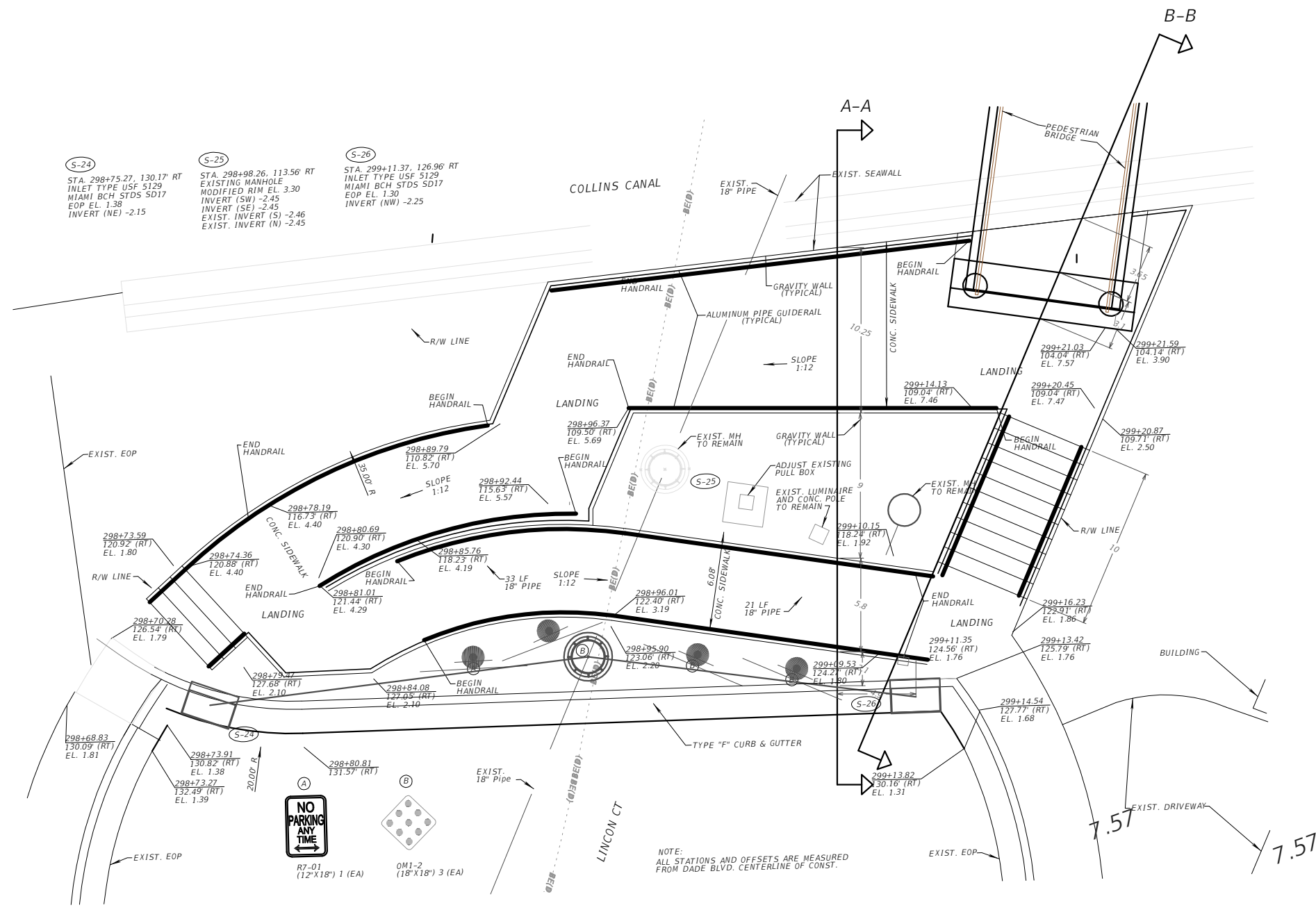

CROSS SECTION A-A

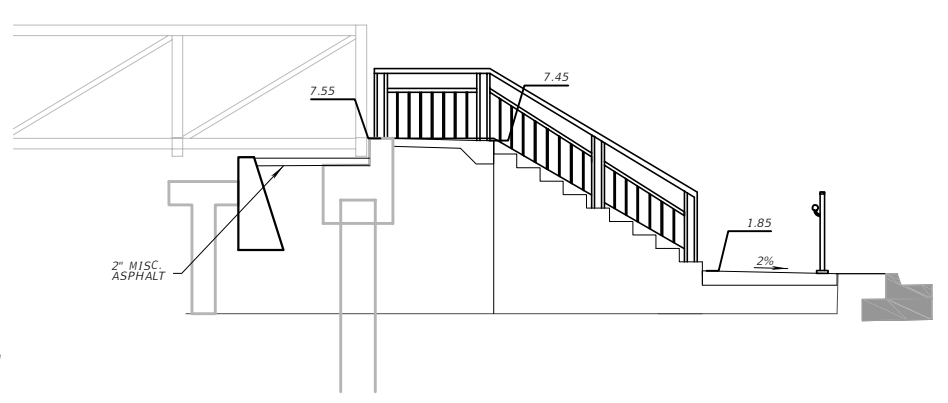

CROSS SECTION B-B

# DRAFT

# EXHIBIT B

**From:** Pena, Giancarlo <GiancarloPena@miamibeachfl.gov>  
**Sent:** Thursday, October 11, 2018 3:56 PM  
**To:** Yandy Fuentes  
**Cc:** Soto, Luis; Brian Thomason; Daniel Veillette  
**Subject:** RE: DRB meeting on Ped-Bridge  
**Attachments:** A0029\_N3-1.jpg; maximus2-1.jpg; Panels.pdf

Yandy,

Below please find recommendation from the design review board.

The method of installation of the “Venetian Bubble” panels shall be further developed and installed on the outside of the bridge support systems. Further, the panels shall extend along the ramping and approach walkways.

Attached please find exhibit.

Thank you,

## MIAMIBEACH

**Giancarlo Peña, P.E., CGC.,** *Civil engineer III*  
PUBLIC WORKS DEPARTMENT  
1700 Convention Center Drive, Miami Beach, FL 33139  
Tel: 305-673-7000 x6343 / Cell: 305-546-2943 Fax: 305-673-7028 / [www.miamibeachfl.gov](http://www.miamibeachfl.gov)

*We are committed to providing excellent public service and safety to all who live, work and play in our vibrant, tropical, historic community.*



*Before you print this email, consider the negative environmental impacts associated with printing.*

---

**From:** Pena, Giancarlo  
**Sent:** Wednesday, October 10, 2018 3:40 PM  
**To:** 'Yandy Fuentes' <[yfuentes@bergeroninc.com](mailto:yfuentes@bergeroninc.com)>  
**Cc:** Soto, Luis <[LuisSoto@miamibeachfl.gov](mailto:LuisSoto@miamibeachfl.gov)>; Brian Thomason <[bthomason@bergeroninc.com](mailto:bthomason@bergeroninc.com)>; Daniel Veillette <[dveillette@bergeroninc.com](mailto:dveillette@bergeroninc.com)>  
**Subject:** RE: DRB meeting on Ped-Bridge

Ok

Thank you

## MIAMIBEACH

**Giancarlo Peña, P.E., CGC.,** *Civil engineer III*  
PUBLIC WORKS DEPARTMENT  
1700 Convention Center Drive, Miami Beach, FL 33139  
Tel: 305-673-7000 x6343 / Cell: 305-546-2943 Fax: 305-673-7028 / [www.miamibeachfl.gov](http://www.miamibeachfl.gov)

*We are committed to providing excellent public service and safety to all who live, work and play in our vibrant, tropical, historic community.*



*Before you print this email, consider the negative environmental impacts associated with printing.*

---

**From:** Yandy Fuentes <[yfuentes@bergeroninc.com](mailto:yfuentes@bergeroninc.com)>  
**Sent:** Wednesday, October 10, 2018 3:38 PM  
**To:** Pena, Giancarlo <[GiancarloPena@miamibeachfl.gov](mailto:GiancarloPena@miamibeachfl.gov)>  
**Cc:** Soto, Luis <[LuisSoto@miamibeachfl.gov](mailto:LuisSoto@miamibeachfl.gov)>; Brian Thomason <[bthomason@bergeroninc.com](mailto:bthomason@bergeroninc.com)>; Daniel Veillette <[dveillette@bergeroninc.com](mailto:dveillette@bergeroninc.com)>  
**Subject:** Re: DRB meeting on Ped-Bridge

Giancarlo,  
It looks like Rick is out of the office until next week. I would recommend to work on the recommendations by the DRB and if Gatorbridge has any questions, we could coordinate a conference call.

Sincerely,

Yandy Fuentes  
Project Manager

**Bergeron Land Development Inc.**  
**[19612 SW 69th Place](#)**  
**[Fort Lauderdale, Florida 33332](#)**  
**Cell:** [\(954\) 658-6775](tel:(954)658-6775)  
**Phone:** [\(954\) 680-6100](tel:(954)680-6100)  
**Fax:** [\(954\) 680-0666](tel:(954)680-0666)  
**Website:** [www.bergeronlanddev.com](http://www.bergeronlanddev.com)  
**Email:** [yfuentes@bergeroninc.com](mailto:yfuentes@bergeroninc.com)

*This message and any and all attachments are intended only for the recipients as named above and may contain confidential, proprietary, and/or privileged information. Unauthorized use, distribution, or reliance upon such information is not allowed. If you have received this message by mistake, please contact the sender and destroy all digital and hard copies.*

Sent from my iPhone

On Oct 10, 2018, at 3:18 PM, Pena, Giancarlo <[GiancarloPena@miamibeachfl.gov](mailto:GiancarloPena@miamibeachfl.gov)> wrote:

Yandy,

I am working on getting all the required information, but can we schedule a conference call for tomorrow 11:00 AM or Friday at 10:00 AM.

Thank you,

# MIAMIBEACH

**Giancarlo Peña, P.E., CGC.,** *Civil engineer III*

PUBLIC WORKS DEPARTMENT

1700 Convention Center Drive, Miami Beach, FL 33139

Tel: 305-673-7000 x6343 / Cell: 305-546-2943 Fax: 305-673-7028 / [www.miamibeachfl.gov](http://www.miamibeachfl.gov)

*We are committed to providing excellent public service and safety to all who live, work and play in our vibrant, tropical, historic community.*



*Before you print this email, consider the negative environmental impacts associated with printing.*

---

**From:** Yandy Fuentes <[yfuentes@bergeroninc.com](mailto:yfuentes@bergeroninc.com)>

**Sent:** Wednesday, October 10, 2018 1:03 PM

**To:** Pena, Giancarlo <[GiancarloPena@miamibeachfl.gov](mailto:GiancarloPena@miamibeachfl.gov)>

**Cc:** Soto, Luis <[LuisSoto@miamibeachfl.gov](mailto:LuisSoto@miamibeachfl.gov)>; Brian Thomason <[bthomason@bergeroninc.com](mailto:bthomason@bergeroninc.com)>; Daniel Veillette <[dveillette@bergeroninc.com](mailto:dveillette@bergeroninc.com)>

**Subject:** RE: DRB meeting on Ped-Bridge

Hi Giancarlo,

Any update on the request below?

Sincerely,

*Yandy Fuentes*

**Project Manager**

**Bergeron Land Development Inc.**

**19612 SW 69th Place**

**Fort Lauderdale, Florida 33332**

**Cell:** (954) 658-6775

**Phone:** (954) 680-6100

**Fax:** (954) 680-0666

**Website:** [www.bergeronlanddev.com](http://www.bergeronlanddev.com)

**Email:** [yfuentes@bergeroninc.com](mailto:yfuentes@bergeroninc.com)

**BERGERON**  
LAND DEVELOPMENT, INC.



<image006.jpg>

*This message and any and all attachments are intended only for the recipients as named above and may contain confidential, proprietary, and/or privileged information. Unauthorized use, distribution, or reliance upon such information is not allowed. If you have received this message by mistake, please contact the sender and destroy all digital and hard copies.*

---

**From:** Yandy Fuentes  
**Sent:** Thursday, October 4, 2018 8:58 AM  
**To:** Giancarlo (Inspector) Pena <[GiancarloPena@miamibeachfl.gov](mailto:GiancarloPena@miamibeachfl.gov)>  
**Cc:** [LuisSoto@miamibeachfl.gov](mailto:LuisSoto@miamibeachfl.gov); Brian Thomason <[bthomason@bergeroninc.com](mailto:bthomason@bergeroninc.com)>; Daniel Veillette <[dveillette@bergeroninc.com](mailto:dveillette@bergeroninc.com)>  
**Subject:** Fwd: DRB meeting on Ped-Bridge

Good morning Giancarlo,  
Please see below from Gatorbridge. Can you accommodate their request. Thank you.

Sincerely,

Yandy Fuentes  
Project Manager

**Bergeron Land Development Inc.**  
**[19612 SW 69th Place](#)**  
**[Fort Lauderdale, Florida 33332](#)**  
**Cell:** [\(954\) 658-6775](tel:(954)658-6775)  
**Phone:** [\(954\) 680-6100](tel:(954)680-6100)  
**Fax:** [\(954\) 680-0666](tel:(954)680-0666)  
**Website:** [www.bergeronlanddev.com](http://www.bergeronlanddev.com)  
**Email:** [yfuentes@bergeroninc.com](mailto:yfuentes@bergeroninc.com)

*This message and any and all attachments are intended only for the recipients as named above and may contain confidential, proprietary, and/or privileged information. Unauthorized use, distribution, or reliance upon such information is not allowed. If you have received this message by mistake, please contact the sender and destroy all digital and hard copies.*

Sent from my iPhone

Begin forwarded message:

**From:** Rick Cawston <[rcawston@cmilc.com](mailto:rcawston@cmilc.com)>  
**Date:** October 4, 2018 at 8:35:00 AM EDT  
**To:** Yandy Fuentes <[yfuentes@bergeroninc.com](mailto:yfuentes@bergeroninc.com)>  
**Cc:** Brian Thomason <[bthomason@bergeroninc.com](mailto:bthomason@bergeroninc.com)>, Daniel



Veillette <[dveillette@bergeroninc.com](mailto:dveillette@bergeroninc.com)>

**Subject: RE: DRB meeting on Ped-Bridge**

Yandy,

Thanks for the update. It sounds like we may be inching closer to an approved design.

Two quick things to help move this along.

1. Can you please have them note their comments on the drawings to help ensure we make the proper revisions in the correct places?
2. Can you confirm these are the final review comments from all reviewers?

From there we can have our engineers review and complete the changes.

Thanks, Rick

**Rick Cawston**  
**Director of Sales**  
**GatorDock & GatorBridge**  
Direct: 770-933-8148 | Mobile: 404-229-7589  
[gatordock.com](http://gatordock.com) | [gatorbridge.com](http://gatorbridge.com) | [cmilc.com](http://cmilc.com)

**Marine Access Solutions**  **Prefabricated Aluminum Bridges**

---

**From:** Yandy Fuentes <[yfuentes@bergeroninc.com](mailto:yfuentes@bergeroninc.com)>

**Sent:** Wednesday, October 3, 2018 5:52 PM

**To:** Rick Cawston <[rcawston@cmilc.com](mailto:rcawston@cmilc.com)>

**Cc:** Brian Thomason <[bthomason@bergeroninc.com](mailto:bthomason@bergeroninc.com)>; Daniel Veillette <[dveillette@bergeroninc.com](mailto:dveillette@bergeroninc.com)>

**Subject:** Fwd: DRB meeting on Ped-Bridge

Hi Rick,

Please see below comments from Giancarlo following yesterday's DRB meeting.

Please call me tomorrow to discuss at your earliest convenience.

Thank you.

Sincerely,

Yandy Fuentes  
Project Manager

**Bergeron Land Development Inc.**

**[19612 SW 69th Place](#)**

**[Fort Lauderdale, Florida 33332](#)**

**Cell:** [\(954\) 658-6775](tel:(954)658-6775)

**Phone:** [\(954\) 680-6100](tel:(954)680-6100)

**Fax:** [\(954\) 680-0666](tel:(954)680-0666)

**Website:** [www.bergeronlanddev.com](http://www.bergeronlanddev.com)

**Email:** [yfuentes@bergeroninc.com](mailto:yfuentes@bergeroninc.com)

*This message and any and all attachments are intended only for the recipients as named above and may contain confidential, proprietary, and/or privileged information. Unauthorized use, distribution, or reliance upon such information is not allowed. If you have received this message by mistake, please contact the sender and destroy all digital and hard copies.*

Sent from my iPhone

Begin forwarded message:

**From:** "Pena, Giancarlo"  
<[GiancarloPena@miamibeachfl.gov](mailto:GiancarloPena@miamibeachfl.gov)>  
**Date:** October 3, 2018 at 8:52:57 AM EDT  
**To:** Yandy Fuentes <[yfuentes@bergeroninc.com](mailto:yfuentes@bergeroninc.com)>  
**Cc:** "Soto, Luis" <[LuisSoto@miamibeachfl.gov](mailto:LuisSoto@miamibeachfl.gov)>  
**Subject:** **RE: DRB meeting on Ped-Bridge**

Yandy,

As per our conversation, the city received approval for the bridge, but DRB requested that the panels to be move in front of the frame and to integrate the panels along the north ramp. Please let me know when can we have a conference call to discuss.

Thank you,

MIAMIBEACH

**Giancarlo Peña, P.E., CGC.,** Civil engineer III  
PUBLIC WORKS DEPARTMENT  
1700 Convention Center Drive, Miami Beach, FL 33139  
Tel: 305-673-7000 x6343 / Cell: 305-546-2943 Fax: 305-673-7028  
/ [www.miamibeachfl.gov](http://www.miamibeachfl.gov)

*We are committed to providing excellent public service and safety to all who live, work and play in our vibrant, tropical, historic community.*



*Before you print this email, consider the negative environmental impacts associated with printing.*

---

**From:** Soto, Luis  
**Sent:** Tuesday, October 02, 2018 9:44 PM  
**To:** Pena, Giancarlo  
<[GiancarloPena@miamibeachfl.gov](mailto:GiancarloPena@miamibeachfl.gov)>  
**Cc:** Yandy Fuentes <[yfuentes@bergeroninc.com](mailto:yfuentes@bergeroninc.com)>  
**Subject:** FW: DRB meeting on Ped-Bridge

Giancarlo, please request a cost proposal from Bergeron. We may have to meet with Yandy specifics.  
Thanks

---

**From:** Carpenter, Eric  
**Sent:** Tuesday, October 02, 2018 1:21 PM

I was able to confirm that we did get DRB approval conditioned on the modifications they requested. We are reaching out to the Design/Builder today to request a change order for the modifications so that can be presented to Commission. Unfortunately I think we are going to be too late for the October Commission meeting but we will push to try to get the item on as soon as possible.

Respectfully,

**Eric T. Carpenter, P.E.**  
**Assistant City Manager**

**MIAMIBEACH**

1700 Convention Center Drive, Miami Beach, FL 33139  
Tel: 305-673-7080 / [www.miamibeachfl.gov](http://www.miamibeachfl.gov)

*We are committed to providing excellent public service and safety to all who live, work and play in our vibrant, tropical, historic community.*



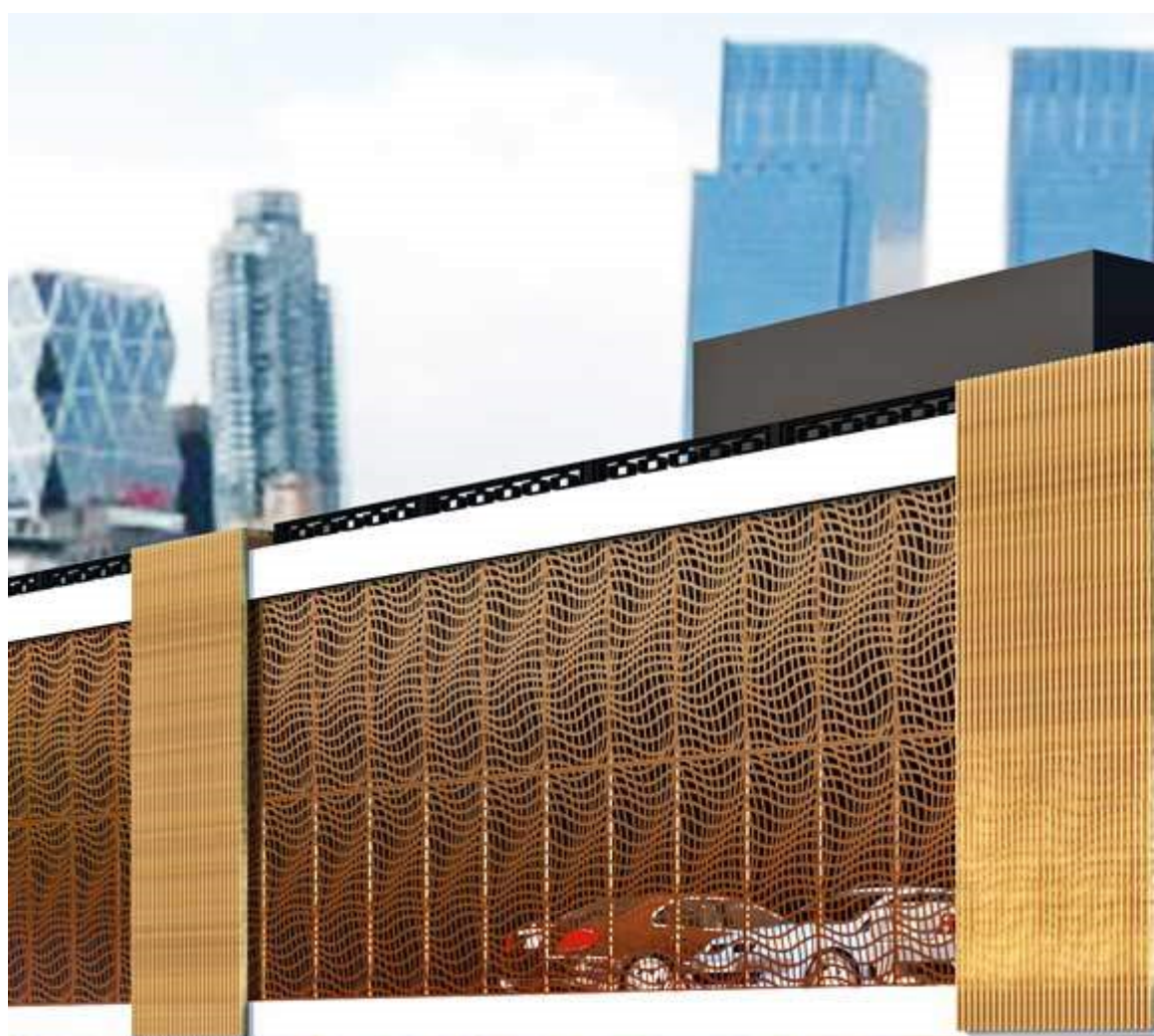

# EXHIBIT C

**From:** Rick Cawston <rcawston@cmilc.com>  
**Sent:** Tuesday, November 27, 2018 7:59 AM  
**To:** Yandy Fuentes  
**Cc:** Brian Thomason  
**Subject:** RE: DRB meeting on Ped-Bridge

Yandy,

My apologies but it took some time to get updated pricing on the larger panels. Below is a summary of the proposed changes and associated costs.

Upgrade Panel Dimension to a 5' tall continuous on length of bridge -	\$16,000
Increase Truss Height by 1' with increased profile and wind load -	\$19,500
Add framing to support panels (previous design utilized existing truss)-	\$14,000
<u>Engineering Redesign of Truss, panels, frames with review and analysis -</u>	<u>\$5,000</u>
Total cost of requested changes -	\$54,500

This does not affect the cost of powder coating at this time, however we have been notified by our powder coater of an increase effective January 1, 2019.

Given that the current design meets the spirit and intent of the rendering provided, along with the cost of the design modifications, our recommendation would be to move forward with the current design and take advantage of 2018 powder coating prices.

Please let us know how your client would like to proceed.

Thanks, Rick

---

**From:** Yandy Fuentes <[yfuentes@bergeroninc.com](mailto:yfuentes@bergeroninc.com)>  
**Sent:** Wednesday, November 7, 2018 8:11 PM  
**To:** Rick Cawston <[rcawston@cmilc.com](mailto:rcawston@cmilc.com)>  
**Cc:** Marta Banister <[MBanister@cmilc.com](mailto:MBanister@cmilc.com)>; Tom Hauer <[THauer@gatordock.com](mailto:THauer@gatordock.com)>; Brian Thomason <[bthomason@bergeroninc.com](mailto:bthomason@bergeroninc.com)>  
**Subject:** Re: DRB meeting on Ped-Bridge

Thank you for the fast response.

Sincerely,

Yandy Fuentes  
Project Manager

**Bergeron Land Development Inc.**  
[19612 SW 69th Place](#)  
[Fort Lauderdale, Florida 33332](#)  
Cell: [\(954\) 658-6775](tel:(954)658-6775)

**Phone:** [\(954\) 680-6100](tel:(954)680-6100)

**Fax:** [\(954\) 680-0666](tel:(954)680-0666)

**Website:** [www.bergeronlanddev.com](http://www.bergeronlanddev.com)

**Email:** [yfuentes@bergeroninc.com](mailto:yfuentes@bergeroninc.com)

*This message and any and all attachments are intended only for the recipients as named above and may contain confidential, proprietary, and/or privileged information. Unauthorized use, distribution, or reliance upon such information is not allowed. If you have received this message by mistake, please contact the sender and destroy all digital and hard copies.*

Sent from my iPhone

On Nov 7, 2018, at 7:30 PM, Rick Cawston <[rcawston@cmilc.com](mailto:rcawston@cmilc.com)> wrote:

We can do grey as a custom color for the \$32,500 quoted. Standard colors are black, white, brown, green and blue are the standard colors that can be done for \$26,000.

Either option would include powder coating the entire bridge structure (excluding decking) but including the panels.