

MIAMIBEACH

City of Miami Beach, 1700 Convention Center Drive, Miami Beach, Florida 33139 , www.miamibeachfl.gov

Facilities and Fleet Management Department
Beach Maintenance Division
Tel: 305-673-7631

Sixth Amended and Restated RULES AND REGULATIONS FOR BEACHFRONT CONCESSION OPERATIONS

The following Rules and Regulations (the "Rules and Regulations") shall apply to Beachfront Concessions within the City of Miami Beach:

1. **DEFINITIONS.**

A. **Beachfront Concession** - beachfront operations authorized by the City of Miami Beach to either: 1) the Upland Owner Concessionaire, or 2) a Direct City Concessionaire, subsequent to the submission of all requirements, which grants the right to use the public beach land to rent or otherwise provide beach equipment (lounges chairs, umbrellas and the like), sell food and beverages and/or rent watersports equipment, or to furnish, with or without charge, any of the foregoing.

B. **Definitions -**

- (1) **Direct City Beachfront Concession Agreement** – A concession agreement between the City and a Direct City Concessionaire that authorizes the operation of a Beachfront Concession, adjacent to public property for the general public
- (2) **Commercial Beachfront Concession Agreement** - A Beachfront Concession letter agreement that is issued to the Upland Owner Concessionaire by the City, which authorizes the operation of a Beachfront Concession adjacent to the Upland Property **for the general public, and/or the guests or residents of the Upland Property at a charge or fee to the user of the Beachfront Concession services, or if the Upland Property collects any resort or membership fee which includes access to the Beachfront Concession services.**
- (3) **Non-Commercial Beachfront Concession Agreement** - A Beachfront Concession letter agreement that is issued to the Upland Owner Concessionaire by the City, which authorizes the operation of a Beachfront Concession solely for the guests and/or residents of the Upland Property, **for which the Upland Property does not charge (i) a fee for use of the Beachfront Concession services; or (ii) a resort or Membership fee, entitling the user to the use of the Beachfront Concession services.**

- (4) **Concessionaire** - any Direct City Concessionaire, **Upland Owner Concessionaire or Third-Party Concession Operator, authorized to operate a Beachfront Concession; provided that the Upland Property has secured all regulatory approvals for, and is open for business as a hotel, condominium, club, public establishment, or other permanent, high-occupancy operation which serves the public and/or guests or residents of the Upland Property.**
- (5) **Direct City Concessionaire** - a provider of beachfront concession management and operation services who has been contracted directly by the City of Miami Beach.
- (6) **Third-Party Concession Operator** - a provider of beachfront concession management and operation services who has been subcontracted by the Upland Owner Concessionaire, excluding Direct City Concessionaires.
- (7) **Upland Owner Concessionaire (Commercial or Non-Commercial) - the legal owner of the Upland Property and operator of a Beachfront Concession** who is authorized, pursuant to a Commercial Beachfront Concession Permit (Commercial Upland Owner Concessionaire) or a Non-Commercial Beachfront Concession Permit (Non-Commercial Upland Owner Concessionaire); to conduct its own Beachfront Concession Operations; and/or to subcontract its Beachfront Concession Operations to a Third-Party Concession Operator.
- (8) **Upland Property - the land adjacent to, and immediately westward of, the public beach. The Upland Property owner shall be determined from the records of the Miami Dade County Property Appraiser's Office, corresponding to the folio number for the Upland Property.**
- (9) **Beachfront Concession Layout** - a schematic plan as depicted and described in ***Page 30, Beach Concession Layout***, submitted to, and approved by, the City of Miami Beach which illustrates, in conjunction with the Concessionaire equipment list, and the Concession Facilities that the Concessionaire is permitted to have.
- (10) **Concession Facilities** - Concession Huts and Storage Boxes (as depicted and described in ***Pages 30 - 34, Beach Concession Design Guideline***, as well as any other items or equipment including, but not limited to, designated children's play area, cooking, heating, and refrigeration equipment or furnishings, trash receptacles approved for use by the City of Miami Beach in connection with the Beachfront Concession.
- (11) **Workable Concession Area** – The Concessionaire shall not place any Concession Facilities outside of the Workable Concession Area unless explicitly identified within this paragraph.
- (a) The placement of Concession Huts, and all storage boxes, shall be within the portion of **the Concession Area bounded on the west by a line no more or less than three feet east of the trash receptacle line. Umbrellas and all styles and sizes of chairs and lounges shall be bounded on the west by a line no less than Six**

(6) feet east of the trash receptacle line. Additional boundaries shall be on the east by the lifeguard line of sight or 10 feet from the mean high-water line, whichever is greater and affords the lifeguard on duty a safe and effective view of the water as determined by the lifeguard on duty, and bounded on the north and south by the extensions of the north and south property lines less Five (5) feet on both the north and south of the Upland Property in the case of an Upland Owner Concessionaire, all as determined by the City of Miami Beach. This configuration will allow for a public use area measuring Ten (10) feet in front of each "Workable Concession Area" plus Ten (10) feet between each concession area. The Concessionaire shall not be allowed to place any Concession Facilities outside of the above-described Workable Area other than a single umbrella secured to the interior side of a 4x4 wood post within the beach access path directly behind the representative Upland Property at a minimum of Twelve feet (12') west of the western edge of the emergency/service vehicular traffic lane. This umbrella is to be fully open with the canopy at a height of no less than Seven feet (7') when in place for greeting and directing the Upland Property guests and residents. It must be removed if not open and in use.

- (b) Children's Play Area- provided a children's play area has been included in the site plan and approved, it shall be located within the Workable Area and be located a minimum of Thirty-five feet (35') east of the trash can line with seating placed on the western side of the play area to be used for parental supervision of children at play. Signage indicating a "children's play area" shall be posted at Fifteen-foot (15') intervals along the eastern edge of the play area. At the end of each day, the temporary children's play area installations shall be removed from the beach and stored away.

(12) **Motor Vehicle** - any City-approved automobile, truck, sport utility vehicle, golf cart, all-terrain vehicle (ATV), Mobile Cooking Concession Facility, or any other means of transportation that is, to the extent required by law, approved and appropriately licensed by the Florida Department of Transportation and /or Florida Department of Motor Vehicles to travel on paved roadways.

(13) **Trailer** - any non-motorized vehicle or other means of transportation (e.g., jet ski trailers), with wheels, or constructed so that it can be fitted with wheels, and which is used or intended to be used for any one of the following purposes:

- (a) The rental of watersports equipment
- (b) The sale of food and/or beverages
- (c) cooking and /or heating of food
- (d) the distribution, delivery, towing and return of anything, including, without limitation, jet skis, towels, chaises, cabanas,

2. **GENERAL CONDITIONS.**

A. Each Applicant to the City for approval as either a Direct City Concessionaire or an Upland Owner Concessionaire and their Third-Party Concession Operators must provide the City with written acknowledgment of their understanding of, and agreement to abide by, these Rules and Regulations, **Pages 36 - 37, Concessionaire Acknowledgement and Authorization** Prior to being granted a Beachfront Concession permit. The entire application must be signed on behalf of the Applicant Concessionaire by a senior management officer and authorized individual; whose signature and authorization are and shall be binding upon Applicant's successors in interest, subject to the successor entity complying with the application and approval process for the permit within thirty (30) days from the date of the sale or transfer of the Applicant's interest; and whose signature must be notarized. The application must be accompanied by a report of the Secretary of State of the State in which the Applicant Concessionaire is organized and a report from the Secretary of the State of Florida, if Florida is the state of incorporation or, in the case of a foreign corporation, reflecting that Applicant is authorized to transact business in the State of Florida. Each such report must be dated not more than thirty (30) days before the submission of the application and must reflect that the Applicant Concessionaire is in good standing and that the applications signer holds a position which indicates his authority to sign the application; and must comply with all of the City's requirements for the application, including the following acknowledgments:

- (1) a written acknowledgment, **Pages 36 - 37, Concessionaire Acknowledgement and Authorization**, of its understanding of, and agreement to abide by, these Rules and Regulations prior to being granted a Beachfront Concession.
- (2) a written acknowledgment of its acceptance of its obligation, as to each person who, on its behalf, is to operate a Motor Vehicle on the beach ("Prospective Driver"), to do the following before the Prospective Driver drives any Motor Vehicle: The operating Concessionaire shall:
- (3) sign, in addition to the Prospective Driver the Safe Driving Agreement in substantially the form attached as **Pages 40 - 43, Vehicle Information Sheet, and Safe Deriving Agreement** or as amended by the City from time to time, with one fully signed original to be submitted with the application package and to be held by the City with the application,
- (4) retain, and make available for inspection by the City upon its request, each such fully signed Safe Driving Agreement throughout the period that the Prospective Driver is operating a Motor Vehicle on behalf of the Applicant Concessionaire and for a period of two years after the Prospective Driver ceases to operate a Motor Vehicle on behalf of the Applicant Concessionaire; and
- (5) prior to the operation of any Motor Vehicle on the beach, the City will require the Prospective Driver to satisfactorily complete a one-hour training course specifically geared to safety and operation of a Motor Vehicle, in compliance with the Safe Driving Agreement, said training to include actual operation by the Prospective Driver of the type of Motor Vehicle which he

or she is anticipated to drive.

- (6) if the Applicant Concessionaire seeks approval as a Direct City Concessionaire, a written acknowledgment that it will not subcontract to any other person or entity the performance of any of its duties and obligations as a Direct City Concessionaire is required, unless otherwise approved in writing by the City pursuant to the Direct City Beachfront Concession Agreement.
- (7) If the Applicant Concessionaire seeks approval as an Upland Owner Concessionaire, a written acknowledgment that, **if it contracts with a Third-Party Concession Operator or multiple Third-Party Concession Operators for the management and operation of all, or parts of, the Beachfront Concession, the Upland Owner Concessionaire shall remain responsible to the City for performing under the terms and conditions of the Beachfront Concession Rules and Regulations,** as may be amended from time to time. **An Upland Owner Concessionaire may contract with more than one Third-Party Concession Operator for separate services. I.e., one for water sports, and another for furnishings. Each of the Third-Party Concession Operators and the Applicant Concessionaire are required to submit their "Acknowledgement and Authorization" Page 36 - 37, as well as their individual certificates of insurance. Under no circumstances may a Third-Party Concession Operator sub-contract any aspect of their services or responsibilities to another party or service provider.**
- (8) The Applicant Concessionaire's application is not complete and will not be considered by the City if any of the City's application requirements are not satisfied. The City reserves the right, before considering any application, to require that any documentation or information be updated, expanded, and resubmitted if it is deemed necessary by the City to clarify and /or to confirm any such documentation or information.
- (9) Any Beachfront Concession granted pursuant to these Rules and Regulations shall not be construed to vest any additional rights upon the Concessionaire that do not otherwise exist, except for the privilege of temporary use of the beachfront in accordance with the conditions and requirements set forth in these Rules and Regulations and all other applicable City, County, State, and Federal laws. **Concessionaires are hereby notified that all beaches within the City of Miami Beach are public and, as such, Beachfront Concession operations must not restrict, or appear to restrict, access or in any way limit the public nature or ambiance of the beachfront. All Concessionaires are required to post in a conspicuous location for all to read a sign approved by the City of Miami Beach which advises all that the *Beach is Open to the Public.***
- (10) There is no responsibility on behalf of the City of Miami Beach for any lost, stolen, or damaged property belonging to a Concessionaire.
- (11) Concessionaires are responsible for any damage caused to any City-owned property and /or the beachfront during the time of its usage of said areas.
- (12) Concessionaires must submit a written evacuation plan to the City for the prompt

removal from the beach of all Motor Vehicles, Trailers, and Concession Facilities and Furnishings. The plan shall be implemented within one (1) hour of notification by appropriate City authorities and within eight (8) Hours of the issuance of a Hurricane Warning by the Miami-Dade County Office of Emergency Management. This plan **Page 39, Evacuation Plan** must be submitted to the City for approval. Each Concessionaire shall conduct a drill once per year, at the City's discretion, prior to hurricane season, to remove all of its Concession Facilities from the beach.

- (13) Each Applicant must further agree to notify the City, within thirty (30) days of any sale or transfer in the interest of Applicant or in the Third-Party Concession Operator entity. The successor entity shall be required to apply for its own Beachfront Concession permit in accordance with the terms and conditions of the Rules and Regulations.
- (14) The City reserves the right to amend these Rules and Regulations. Said amendments shall be binding on all Concessionaires.

3. BUSINESS TAX RECEIPTS AND FEES.

- A. **Business Tax Receipts** – As related to a Beachfront Concession, a City Business Tax Receipt (valid from October 1 through September 30 of the following year) is required for (1) each Upland Owner Concessionaire for the operation of the Upland Property; and (2) each Direct City Concessionaire in connection with the Beachfront Concession activities which such Direct City Concessionaire operates
- B. In addition to the Business Tax Receipts required in Paragraph 3(a) above, an Upland Owner Concessionaire shall pay an **Upland Fee, per Upland Unit. The fee will increase annually in accordance with the Consumer Price Index (CPI) as determined by the U.S. Department of Labor Statistics.** The number of Upland Units shall be determined by the City's Finance Department or designee as will the CPI adjustment amount.
- C. If the Upland Owner Concessionaire requests that the Concession Area be utilized by any additional property or properties, other than the Upland Property, the same Unit fee shall apply to any additional properties based on the number of units in each of the additional properties. Additional properties are those non-beachfront properties which are permitted by agreement with the Upland Property to utilize the beachfront and Beachfront Concession amenities of the Upland Property. There shall be no maximum Unit Fee for Beachfront Concessions utilized by multiple properties. These fees shall be due and payable in advance to the City's granting authorization for a Beachfront Concession, and prior to October 1, of each year.
- D. **Any additional property granted approval to utilize the beach and the beachfront amenities of an upland property, (1) must be physically located within the city limits of the City of Miami Beach and (2) maintain Liability Insurance in the same manner as the upland property with the City of Miami Beach listed as co-insured and certificate holder.**
- E. Direct City Concessionaire Fees - In addition to the Business Tax Receipts required in Paragraph 3(a) above, a Direct City Concessionaire will pay the City a concession fee, to be negotiated between the Direct City Concessionaire and the City, in connection with the operation of a Beachfront Concession, to be delineated in the Direct City Beachfront Concession Agreement.

4. **LATE FEES**

Any payment of fees invoiced and due associated with the operation of any Beachfront Concession including the Mobil Cooking Concession Facility which is not paid on or before the respective due date provided for in the application for Beachfront Concession Operations shall be subject to interest of Eighteen percent (18%) per annum or the maximum interest rate allowable under Florida law from the payment due date until such time as the payment in full is actually received by the City. In addition, any payment received after Five (5) Days of its due date shall accrue a late payment fee equal to Ten percent (10%) of the invoiced amount and additional late payment fees thereafter payable on each Thirty (30) day interval until paid in full.

5. **INSURANCE**

A. Every Concessionaire must maintain the required Beachfront Concession Insurance set forth in the attached **Page 44, Beach Concession Insurance Requirements** at all times. Every Concessionaire shall:

- (1) furnish to the City a Certificate of Insurance, in customary form and substance, evidencing compliance with those requirements; and
- (2) furnish to the City a renewal Certificate of Insurance, in customary form and substance, evidencing compliance with these requirements, at least fifteen (15) calendar days before:
 - (a) the expiration of a current Certificate of Insurance; or
 - (b) the effective date of any cancellation of the insurance.

- B. **In the event the Concession Area is utilized or operated by any additional person or entity each such person or entity must maintain the required Beachfront Concession Insurance at all times.** The Concessionaire is responsible for compliance with these requirements by said additional person or entity. This Paragraph 4(B) shall not be interpreted or applied in any manner to diminish the responsibilities of the Concessionaire or to authorize the use of the Concession Area by any additional person or entity.

6. **CONCESSION AREA.**

A. Each Concessionaire shall comply with the approved Beachfront Concession Layout which sets forth the Workable Area of the Beachfront Concession and shall stay within the Workable Area. The Concessionaire shall not be allowed to place Concession Facilities anywhere outside of the Workable Area. The Concessionaire shall not permit patrons to place any chairs, umbrellas, or any other items/equipment belonging to the Concessionaire outside of the Workable Area. The only exception to this requirement shall be the placement of a single umbrella as stipulated in **Workable Concession Area, Page 3 of 46, Section 1. B. (11), (a).**

B. Notwithstanding Paragraph 6(A) above, due to the irregular curve of the beach at 20th Street, the Concessionaire immediately south of 20th Street shall be permitted to occupy

the Street end of 20th Street. Use of street ends by Concessionaires at all other locations is prohibited.

C. Concession Facilities, other than trash receptacles and beach chairs /umbrellas, shall not occupy more than forty percent (40%) of the north /south distance of the Workable Area. By way of example, if the north/south distance of the Workable Area is 100 feet, and the Concession Huts and Storage Boxes are 10 feet by 10 feet each, there shall be no more than a combination of four (4) Concession Huts and/or Storage Boxes permitted within the Workable Area. Notwithstanding the foregoing, Concession Huts and/or Storage Boxes shall be permitted to be placed/stacked east and west of each other. **However, under no circumstances may this east to west stacking exceed Three (3) Concession Huts and/or storage boxes.**

D. Concessionaires shall place, if included as part of the Beachfront Concession Layout, one (1) Storage Box at the southwest corner of the Workable Area and one (1) Storage Box at the northwest corner of the Workable Area, as a means to identify said boundaries of the Workable Area.

E. The Workable Area shall be set up every day no earlier than one (1) hour after sunrise and removed no later than sunset, except that from April 1 to October 31 Concessionaires must wait until Miami-Dade County has conducted its morning turtle nesting survey before commencing set up (the "Operating Hours"). Set up of the workable area shall not occur until the later of the one (1) hour after sunrise or the completion of the Sea Turtle survey.

F. The Concessionaire shall post signs which state "BEACH OPEN TO THE PUBLIC" on all Concession Huts and Storage Boxes. Said signs shall include, for commercial Beachfront Concessions, the prices to be paid by the public, to the extent applicable, for food and beverages, the rental of watersports equipment, and the rental of beach furnishings and equipment. Said signs shall require prior written approval by the City.

- (a) Upon the recommendation of our City Attorney, All Concessionaires should post warning signs on their concession structures warning beachgoers of inherent dangers of the ocean. The recommended language appears below.

BEACH SAFETY RULES
FOR YOUR OWN SAFETY IT IS REQUIRED
THAT YOU UNDERSTAND AND TAKE HEED OF THE FOLLOWING

DUE TO THE INHERENT DANGER OF CONSTANTLY CHANGING OCEAN, SURF CONDITIONS AND WEATHER, PLEASE BE ADVISED THAT WHEN ENTERING THE OCEAN, THERE ARE NATURALLY OCCURRING, UNCONTROLLABLE CONDITIONS, AS WELL AS INHERENT RISKS WHICH COULD PHYSICALLY HARM YOU (AND POSSIBLY CAUSE DEATH), SUCH AS WIND, WEATHER, WAVE, SURF, AND WATER CONDITIONS, AS WELL AS, AMONG OTHER THINGS, SANDBARS, SEA LIFE, RED TIDE, GLASS, AND SUBMERGED ARTICLES, NONE OF WHICH CAN BE CONTROLLED.

G. The Concessionaire shall post the following items in a visible location inside the Concession Huts: 1) a copy of the Business Tax Receipt, 2) a copy of these Rules and Regulations,

and 3) basic operating procedures for Concessionaire staff, which procedures shall be subject to review and approval by the City (i.e., time of deployment of equipment, location of equipment, collection of trash, etc.).

H. Concession Facilities shall be neat, clean, and well maintained at all times. The Concession Area and operation must be aesthetically pleasing and non-detrimental to the surrounding environment. Any graffiti shall be removed or re-painted with matching paint within twenty-four (24) hours. Beachfront concession storage sheds and concession huts will be inspected regularly. If found to be in need of repair, maintenance, or replacement a notice of violation shall be issued, and a period of time will be noted for corrective action.

I. Beachfront Concession activities, including the placement and/or use of umbrellas, canopies, etc., shall not obstruct the view of a lifeguard. **Any request from a lifeguard to relocate any item that obstructs his/her view shall be treated as an emergency and the item shall be relocated immediately without question.**

7. FOOD AND BEVERAGE SERVICE.

(a) A Food Service license issued by the Florida Department of Business and Professional Regulation - Division of Hotels and Restaurants for the food service unit must be supplied by the Applicant for a Beachfront Concession before a City Business Tax Receipt for a Food and Beverage Beachfront Concession may be issued.

(b) If the Beachfront Concession includes Food and Beverage service, then at least one supervisory employee must possess a Food Service Management Certification issued by the Miami-Dade County Public Health Department. In addition, each food service facility must be licensed by the Florida Department of Business & Professional Regulation - Division of Hotels and Restaurants (8240 NW 52 Terrace, Suite 101, Doral, Florida, 33166; telephone: 850-487- 1395).

(c) **Any Upland Property which provides Food and Beverage services shall schedule sifting of their beachfront by an insured, City approved vendor at a frequency of twice monthly. The cost of this sifting service shall be borne by the Upland Property holding the beachfront Food and Beverage permit.**

(d) **Concessionaires shall not vend or offer glass containers, metal containers, unless such bottle or container is primarily composed of aluminum., plastic lids, single use plastic beverage straws, single use plastic stirrers, except that plastic beverage straws or plastic stirrers may be provided to an individual with a disability or medical condition,** as described in Section 11. Notwithstanding the foregoing, recyclable plastic bottles, bottles or containers which are primarily composed of aluminum will be permitted. The use of plastic bags (except for large plastic bags used for trash collection) shall not be permitted.

(e) **100% Reusable Ware Requirement for Concessionaires (Excluding take-out Food and Beverage service provided by Mobile Cooking Concession Facility).** The requirements of **this subsection 6(d) shall become effective on ~~October 16, 2020~~ October 1, 2024.**

- (1) All Concessionaires approved for, and who are issued a Beachfront Concession permit authorizing the Upland Property to provide Beachfront Concession services which include food and beverage services are required to utilize 100% reusable wares in connection with the containment, delivery, display, consumption and retrieval of all items used for the purpose of providing Food and Beverage services in the Concession Area on the

beach. Reusable wares shall include, but are not limited to, tableware serving dishes/containers, condiments, plates, bowls, hot and cold cups, and flatware. Notwithstanding the foregoing, Concessionaires will be permitted to use napkins made from recycled materials and wooden coffee stirrers. All reusable wares are required to be collected and removed from the beach by the Concessionaire upon conclusion of their use. This reusable ware requirement shall not apply to take-out Food and Beverage services provided by mobile cooking and heating Concession Facilities, as more particularly described in Subsection (g).

(f) Mobile Cooking Concession Facilities.

The following requirements shall apply to Mobile Cooking Concession Facilities:

- (1) Mobile Cooking Concession Facilities will only be permitted at those locations operating pursuant to a valid, City-issued Business Tax Receipt and a Beachfront Concession permit which specifically authorizes a Mobile Cooking Concession Facility.
- (2) Mobile Cooking Fee - A Mobile Cooking Concession Facility must be applied for by the Upland Property owner to the City immediately upon serious consideration and well prior to any purchase of such a Concession Facility, or its appliances and/or facilities. The application must contain full detail on the size, dimensions, electric power source and capacity, fuel source and capacity, intended appliances and their power consumption, and a certified acknowledgement from the original equipment manufacturer, confirming that the original equipment, as manufactured, is capable of accepting, handling, and properly and safely functioning with the addition of all additional equipment, amenities, modifications and alterations proposed by the Upland Property owner. If the Upland Owner Concessionaire is authorized to use a Mobile Cooking Concession Facility, the Upland Owner Concessionaire shall also pay a Mobile Cooking Fee, in the fixed annual amount of \$120,000.00, payable on a monthly basis, in the amount of \$10,000.00. The monthly Mobile Cooking Fee shall be paid, in advance, on the first day of each month.
- (3) No Mobile cooking and/or heating Concession Facility manufactured Ten (10) or more years prior shall be permitted to operate on the beachfront.
- (4) Notwithstanding any other provisions contained herein, all mobile cooking and/or heating concession facilities must be removed from the beach at least one (1) hour before sunset, shall not be permitted to remain on the beach overnight, and shall not be located on the beach prior to one (1) hour after sunrise or, during Sea Turtle Nesting season (April 1 to October 31) prior to the completion of the nesting survey.
- (5) In order for a Mobile Cooking Concession Facility to be approved and permitted on the Workable Concession Area, the Upland Property must also have secured approval of Beachfront Food and Beverage services, except in the case of a Direct City Concessionaire Agreement. The use of a Mobile Cooking Concession Facility shall also require at least one supervisory employee who must possess a Food Service Management Certification issued by the Miami-Dade County Public Health Department. This may be the same employee who oversees the Beachfront Food and Beverage

concession operation on the Upland Property. In addition, each food service facility must be licensed by the Florida Department of Business & Professional Regulation - Division of Hotels and Restaurants (8240 NW 52nd Terrace, Suite 101, Doral, Florida, 33166; telephone: 850-487- 1395).

- (6) **Only City-approved Concession Facilities will be permitted.** All mobile cooking and /or heating Concession Facilities must be approved by the Planning Department, Design Review Board or their designated authority as to color, size, style, power source, additional equipment, alterations to OEM specifications, and modifications for any given location. Any and all mobile cooking and /or heating Concession Facilities must receive prior approval by the City Manager, in accordance with the City Planning Department's current Beachfront Concession Design Guidelines or any other such design as may be approved by the City Manager and the City's Planning Department or designated staff. No Trailer manufactured before 2016 is permitted on the beachfront.
- (7) Mobile cooking and/or heating Concession Facilities will only be permitted on the beachfront in accordance with applicable City, County, State, and Federal laws, and shall be inspected at least once per year by the City's Fire Department.
- (8) Cooking and/or heating Concession Facilities shall only be permitted by means of battery powered, solar powered, or propane gas systems, that are properly approved, permitted, and installed in accordance with applicable City, County, State, and Federal laws. The use of electricity-producing generating Mobile devices (generators) is prohibited.
- (9) Upland Owner Concessionaires who are authorized to provide mobile cooking and/or heating Concession Facilities may provide patrons table seating immediately adjacent to the cooking and/or heating Concession Facility. Each mobile cooking and/or heating Concession Facility may provide a maximum of ten (10) tables, with no more than one Umbrella and four (4) chairs per table. All facilities are subject to approval by the Planning Department. Notwithstanding any other provisions contained herein, all mobile cooking and /or heating Concession Facilities must be removed from the beach by sunset; shall not be permitted to remain on the beach overnight; and shall not be located on the beach prior to 1 hour after sunrise.

(g) **Take-Out Food and Beverage services provided by Mobile Cooking Concession Facility.** In connection with providing take-out Food and Beverage services, Upland Owner Concessionaires shall pursue the use of service articles made of biodegradable or recycled materials, including, but not limited to, tableware, serving dishes/containers, condiments, plates, bowls, hot and cold cups, napkins, wooden coffee stirrers and flatware. The City encourages the use of unbleached, non-coated, recycled content, paper food service articles and other fiber-based food service articles as the most environmentally preferred alternatives. No plastic bags should be distributed; instead, the Applicant should use paper or reusable bags (materials can vary, such as calico, cotton, hemp, jute and others).

(h) Upland Owner Concessionaires are encouraged to reduce the amount of packaging and use packaging that does not contain packaging inks, dyes, pigments, adhesives, stabilizers, and additives with levels of lead, cadmium, mercury or hexavalent chromium in packaging inks, dyes, pigments, adhesives,

stabilizers, and additives equal to or greater than 100 parts per million, which is consistent with packaging statutes adopted by 19 U.S. states. The following exceptions apply to this heavy metal threshold recommendation for packaging:

- a. Packaging made from recycled materials.
- b. Packaging that is essential to the protection, safe handling, or function of the package's content.
- c. Packaging having a controlled distribution and reuse (i.e., beverage containers subject to mandatory deposit requirements); and
- d. Packaging or packaging component that is glass or ceramic where the decoration has been vitrified (Definition: Vitrified glass is glass that has been fired at an ultra-high temperature so that it is nonporous and extremely durable) and when tested meets specific requirements.

8. **WASTE DISPOSAL.**

(a) The Concessionaire shall provide, at its sole expense, at least two (2) City approved trash receptacles (one (1) for trash clearly labeled "Trash" or "Non-Recyclable" and one (1) for recyclable materials Clearly labeled "Recyclable" with a secure lid with a seven-inch (7") round hole for depositing recyclables within the confines of the Concession Area, approved for its use and for the use by the public. Disposal of the contents of said trash receptacles, and the removal of all other trash or litter from the Concession Area, shall be performed in accordance with Section 7(b), and shall be the sole responsibility of the Concessionaire.

(b) Each Concessionaire shall be responsible, at all times throughout the day, for the collection of all trash, litter, within the entire Concession Area. Additional trash and litter collection exercises shall be performed prior to the placement of any umbrellas or chairs each morning, hourly by concession staff at all concession locations between the hours of 12 PM and 5PM and at the end of each day of operation. All such materials shall be identified as either trash or recyclable and placed in the appropriate cans for trash or recyclable items. Unless otherwise approved in writing by Miami-Dade County, all such materials collected by the Concessionaire must be removed from the beach and disposed of by the Concessionaire and shall not be placed in the Miami-Dade County or City of Miami Beach serviced trash receptacles or dumpsters under any circumstances.

(c) **Food and Beverage Waste (including Mobile Cooking Concession Facilities).** Any waste items, unconsumed food or beverage, food remains such as bones, fruit skins, or other remaining food matter will be placed in a clear plastic bag which will prevent leakage by the Concessionaire and placed in the appropriate trash can for collection and disposal. Upland Owner Concessionaires are responsible for all trash and debris generated by the utilization of any approved mobile cooking and/or heating Concession Facility on the beach.

(d) The City and or the county shall charge Concessionaires for the costs of special clean up necessary should Concessionaires fail to reasonably perform.

9. STORAGE.

(a) There shall be no overnight storage of any kind east of the dune Rope and Post fence line of any kind within the dune. The following will be permissible on the beach:

- (1) Beach chairs, day beds, and cabanas will be permitted to remain within the Workable Area overnight, as long as they are in good condition, neatly stacked, and orderly arranged side-by-side, running east and west, immediately adjacent to the Storage Boxes/Concession Huts. All chairs, day beds, and cabanas shall be secured with a cable and/or a locking mechanism to prevent unauthorized access and use. This cable when removed shall be secured within the Concession Hut to ensure that it does not get entangled and damage the beach sifting equipment. The Upland Property will be responsible for any and all damage to sifting equipment caused by failure to properly secure the said cable. Stacked equipment shall not interfere with beach cleaning and grooming operations, as determined by the City of Miami Beach. In no event shall the stacked equipment exceed a height of eight (8) feet.

Trailers for storage shall not be permitted anywhere on the beach at any time, or on any adjacent dune area or spoil area (west of the dune area). The Storage or parking of Jet Ski trailers, unless actively deploying jet skis, shall not be permitted on the beach or any adjacent dune area or spoil area.

10. STAFFING.

(a) During operating hours, each Concession Area shall have at least one (1) employee on-site at all times.

(b) **All employees of the Concessionaire working within the Concession Area shall wear uniforms, which include the name of the Concessionaire,** and must comport themselves in a professional and courteous manner at all times during Operating Hours. In the event the uniforms do not include the name of the employee, then there must be an employee roster contained at the Concession Hut. The Concessionaire is responsible for the actions, behavior, and work permits for each of its employees and its subcontractor's employees.

(c) Each Concessionaire must conduct its operations so as to maintain reasonable quiet and make no public disturbances. Hawking to attract attention, and/or summoning or accosting any person is prohibited. The playing of any music or allowing any other activity that disturbs the public is prohibited.

11. SPECIAL EVENTS.

For any use or operation, other than that specifically authorized for a Beachfront Concession, the Concessionaire must comply with any requirements imposed pursuant to Section 12-5 of the City Code and any other applicable City, County, State, and Federal requirements. A special events permit Field Monitor will be on site to enforce load-in, load-out, and event permit procedures and requirements. This Field Monitor will issue Permit violations and ensure corrective action is taken in an acceptable time period considering the nature of the violation. In the event a

Field Special Events Monitor or the Beach Maintenance Field Supervisor should learn of any violation involving the dune or its vegetation, immediate notification to Environment and Sustainability shall be provided.

12. ENVIRONMENTAL

(a) Pursuant to Section 46-92 (c) of the Code of the City of Miami Beach, as may be amended from time to time, it is unlawful to carry onto the beach any expanded polystyrene product, single use plastic beverage straws or single use plastic stirrers, except that the prohibition relating to single use plastic beverage straws or plastic stirrers shall not apply to a person or patron with a disability or medical condition that impairs the consumption of beverages without a single-use plastic beverage straw or plastic stirrer. Concessionaire is prohibited from selling, using providing food in, or offering the use of expanded polystyrene food service articles(excluding expanded polystyrene food service articles used for packaged food that have been filled and sealed prior to receipt by Concessionaire). Except as permitted, Concessionaire is prohibited from selling, using, providing food in, or offering the use of plastic beverage straws or plastic stirrers on the beach. Additionally, pursuant to Section 46-92(c) of the Code of the City of Miami Beach it is unlawful for any person to carry onto any beach in the City or for any concessionaire to use, provide, or offer any glass or metal bottle or glass or metal containers excluding any metal bottle or container which is primarily composed of aluminum. Concessionaire is prohibited from selling, using, providing food in, or offering the use of glass or metal bottles or glass or metal containers excluding any metal bottle or container which is primarily composed of aluminum.

(b) Pursuant to Section 82-7 of the City Code, as may be amended from time to time, Concessionaire is prohibited from selling, using, providing food in, or offering the use of expanded polystyrene food service articles (as defined in City Code Section 82-7) on the Concession Area. A violation of this subsection (b) shall be deemed a violation under the terms of Concessionaire's permit or agreement, and grounds for revocation of a special event permit. This subsection (b) shall not apply to expanded polystyrene food service articles used for prepackaged food that have been filled and sealed prior to receipt by Concessionaire.

(c) Additionally, pursuant to Section 82-8 of the City Code, as may be amended from time to time, Concessionaire is prohibited from selling, using, providing food in, or offering the use of single-use plastic beverage straws or single-use plastic stirrers (as defined in City Code Section 82-8) on the Concession Area. A violation of this subsection (b) shall be deemed a default under the terms of Concessionaire's permit or agreement, and grounds for revocation of a special event permit. Notwithstanding the above, the requirements of Section 82-8 shall not restrict Concessionaire from providing a beverage with, or offering the use of, a single-use plastic beverage straw or single-use plastic stirrer to an individual with a disability or medical condition that impairs the consumption of beverages without a single-use plastic beverage straw or single-use plastic stirrer.

(d) As additional consideration for Concessionaire's permit, separate and apart from the requirements of Sections 82-7 and 82-8 of the City Code, Concessionaire agrees:

(1) not to sell, use, provide food in, or offer the use of expanded polystyrene food service articles on the Concession Area. A violation of this subsection (d)(1) shall be deemed a default under the terms of Concessionaire's permit and grounds for revocation of a special event permit. Notwithstanding the above, this subsection (d)(1) shall not apply to expanded polystyrene food service articles used for prepackaged food that have been filled and sealed prior to receipt by Concessionaire; and

(2) not to sell, use, provide food in, or offer the use of single-use plastic beverage straws or single-use plastic stirrers on the Concession Area. A violation of this subsection (b)(2) shall be deemed a default under the terms of Concessionaire's permit. Notwithstanding the above, Concessionaire shall be permitted to provide a beverage with, or offering the use of, a single-use plastic beverage straw or single-use plastic stirrer to an individual with a disability or medical condition that impairs the consumption of beverages without a single-use plastic beverage straw or single-use plastic stirrer.

Pursuant to Section 82-482 (a) of the Code of the City of Miami Beach, as may be amended from time to time, it is unlawful and prohibited for any person to conduct, or permit to be conducted, the storing of beach equipment, tents, or other materials in the vegetated dune area. It is unlawful and prohibited for any person to destroy, mutilate, break, move, tear up, carry away, harvest, traverse upon, or alter in any manner any dune and/or beach vegetation, fencing, rope and post, public access structures, public beach structures, or fixtures occurring naturally or planted or erected by the city or its agents. Additionally, pursuant to Section 82-482 (a) of the Code of the City of Miami Beach, it is unlawful for any person to walk or traverse in the dune, or drive or operate a motor vehicle in the dunes. Lastly, it is unlawful and prohibited for any person to excavate, mine and remove, or haul sand or soil from the beach or dune.

13. **WATERSPORTS (Jet Ski and In-Water Towable) AND PARASAILING**

The following regulations specifically apply to Concessionaires offering watersport concessions and parasailing:

(a) **Propeller crafts have been approved with propeller guards for shuttle purposes to and from the Parasail vessel only and for Parasail passenger participants only. The shuttle vessel may only operate within an established watersports channel which is properly marked as stated in Section 12 Watersports, sub-section (e). Life jackets are required to be worn by all passengers while on the shuttle vessel and the Parasail vessel. Per Florida SS 327.27 "A person may not operate a vessel on any waters of this state towing a person attached to a parasail or similar device unless there is a person in the vessel, in addition to the operator, in a position to observe the progress of the person being towed. A wide-angle rear-view mirror is not acceptable for this purpose."**

(b) All operations that involve the use of a jet ski and/or in-water towable watercraft must have a "chase watercraft vessel" of equal or greater horsepower readily available for problems that may arise during the rental of water sports equipment and be in good working order. The "chase watercraft vessel" is subject to the prior approval of the City.

(c) The operation of all watersport activities (motorized and non-motorized) shall be conducted outside the 300-foot restricted swim area and no closer than 400 feet of any lifeguard stand. The location of each watersport concession shall be subject to the approval of appropriate City Departments.

(d) Concessionaires are responsible for instructing clients on the safe operation of water sports equipment including, without limitation, directions to stay out of all restricted swim areas; to wear a lifejacket at all times; and how to use, and the circumstances for use of, the kill switch.

(e) In its application, each Concessionaire must identify a channel (adjacent to the Concession Area) to be used as an access route through which users of watersport equipment may leave the beachfront and enter open water. Said channel shall be a minimum of 25 feet in width and shall extend 300 feet east, and perpendicular to the shoreline and be marked by removable, orange-

colored buoys which shall be a minimum of eighteen (18) inches in diameter. There shall be a minimum of four (4) buoys on each side of the channel, equally spaced. The water channel shall be marked by the Concessionaire before watersports equipment is used. The channel, and any changes in the channel, must be approved as provided in Section 12(n).

(f) Watercraft shall not exceed "idle speed" within the channel.

(g) The continuous wearing of a life jacket is required for all watersport activities (i.e., wave runners, jet skis, kayaks, paddle boards, and Parasailing etc.). All life jackets must be approved by the U.S. Coast Guard and be in good condition. Concessionaires shall supply all users of watersport equipment with life jackets in appropriate sizes.

(h) Each Concessionaire must comply with the following Florida Statutes, and as such Statutes may be amended. These statutes are overseen and enforced primarily by the State of Florida Fish and Wildlife Conservation Commission, Division of Law Enforcement. These statutes include F.S. 327.39, F.S. 327.395, and F.S. 327.54, which include, in part, the following:

- (1) All persons under the age of 14 cannot operate or rent a personal watercraft ("PWC").
- (2) All persons 14 years of age or over, but under age 18, can operate a PWC with a boater ID card but cannot rent a PWC.
- (3) All persons 18 years of age, and born on or after January 1, 1988, can rent and operate a PWC with a photographic identification and a Florida boating safety identification card issued by the commission; a state-issued identification card or driver license indicating possession of the Florida boating safety identification card; or photographic identification and a temporary certificate issued or approved by the commission.
- (4) All persons born before January 1, 1988 must meet the age requirement to rent and operate a PWC.
- (5) Valid identification shall be required by the Concessionaire.

(i) Parasailing shall be conducted only from winch boats operating beyond the restricted swim areas. The propellered shuttle taking clientele to and from the Parasail Vessel to and from the near shore must be equipped with a propeller guard, may only operate within the marked watersports channel and only at idle speed.

(j) All watercraft equipment shall meet the registration and license requirements of the State of Florida.

(k) All motorized watersports equipment shall be equipped with approved kill switches in good working order. The watersports equipment driver shall wear the kill switch activator at all times.

(l) Fueling watersports equipment is allowed on the beach under the following conditions only: signs must be posted where the gasoline is kept; cans which are spill-proof must be used; residents, tourists, and the general public, must be kept a safe distance from

where the fuel is stored and where the fueling process is taking place. Fuel shall not be stored on the beach overnight. Fueling must be completed over a secondary containment vessel to prevent spillage and contamination of beach sand. Any fuel spill on the beach shall be reported immediately to City of Miami Beach Fire, Police, Ocean Rescue, Environment and Sustainability, and Beach Maintenance.

(m) The equipment permitted to be used in a watersport Beachfront Concession operation consists of a maximum of five (5) waverunners for rent, and a combined total of six (6) kayaks and/or paddleboards for rent. Notwithstanding the foregoing, the Beachfront Concessions located at 1601 Collins Avenue (Loews Hotel) and 4441 Collins Avenue (Fontainebleau Hotel) have additional grandfathered equipment, including additional waverunners, banana boats, and parasail operations.

(n) Any change to, or addition of, a watersport Beachfront Concession, or the implementation of a new water channel to accommodate a new watersport Beachfront Concession operation, shall require review by, and a recommendation from, the Marine and Waterfront Protection Authority, as well as written approval by the City Manager or his/her designee.

14. MOTOR VEHICLES, TRAILERS AND CONCESSION FACILITIES.

(a) A Concessionaire's Motor Vehicle shall only be allowed on the beach for purposes of supplying the Beachfront Concession, and, if and to the extent authorized, to initially deploy equipment and a Trailer at the beginning of the day, to remove the equipment and Trailer (if a Trailer is authorized) at the close of operations each day, and the Concessionaire's Motor Vehicle must leave the beach immediately thereafter. Said supplying, deployment, and removal operations shall only be permitted during a Concessionaire's regular hours of operation and shall be completed safely. No Motor Vehicle or Trailer is permitted on the beach before 1 hour after sunrise or after sunset. Access to the beach shall only be permitted via the predetermined and assigned beach access points/dune crossovers authorized for such use and nearest to the Concession Area as reflected in the Concession application.

(b) Motor Vehicles, including Motor Vehicles with attached Trailers, operated on the beach shall not exceed 5 M.P.H. and shall only operate on the "hard packed sand" area in the immediate vicinity of the Concession Area for which they service and are employed, or to-and-from the predetermined and assigned beach access point for the property they serve. After transporting equipment to a Concession Area the Motor Vehicle, and any Trailer attached thereto, shall be removed from the beach. Driving on the beach shall be kept to a minimum. No Concession-related vehicular traffic will be permitted on the beach, at any time or for any purpose, other than as stated and as approved herein.

(c) Eighteen-inch (18") high cones, orange in color, shall be placed in front of, and at the rear of, a Motor Vehicle or Trailer when parked on the beach. Concessionaires must inspect the perimeter of the Motor Vehicle or Trailer and surrounding area, prior to starting the engine, to assure a clear path of egress and only proceed with extreme caution.

(d) All Motor Vehicles, Trailers and/or Concession Facilities must each display on each side of the vehicle a "Beach Vehicle Pass" decal containing a unique Identification Number which shall be issued and provided for by the City. No other identification or signage of any kind shall be displayed, except that the name of the Concessionaire which owns and operates the Motor Vehicle, Trailer, and /or Concession Facility may also be displayed, in which

case the Upland Owner Concessionaire (if any) may also add its name. The two (2) decals must be placed on opposing sides of the vehicle (either front/back or left/right). The Identification Number will correspond to the number on the City file which contains originals or copies of all applications, permits, correspondence, and other materials which concern or relate to the Beachfront Concession and/or the Beach Vehicle Pass decals which have been issued. Concessionaire with multiple Motor Vehicles, Trailers, or Concession Facilities will receive a unique Identification Number for each such Motor Vehicle, Trailer and /or Concession Facility. As to each Motor Vehicle, Trailer, or Concession Facility for which the City issues Beach Vehicle Pass decals, the City shall advise the Concessionaire in writing of the limits applicable to each such Motor Vehicle, Trailer, or Concession Facility, including the limited area , the limited range, and the limited points of entry to and exits from the beach. Such limits shall be reflected in a document issued by the City which must be displayed on the Motor Vehicle, Trailer, or Concession Facility, at all times.

(e) Each Beachfront Concession shall be limited to the use of one (1) Motor Vehicle servicing the Concession Area at a time and one (1) Trailer, to supply and/or service the Beachfront Concession. Notwithstanding the foregoing, Beachfront Concessions authorized to provide watersports shall be allowed one (1) additional Motor Vehicle to service the watersports operation; and in the event the Upland Property is operating a Mobile Cooking Concession Facility, one additional cargo cart may be approved for the delivery of supplies and the removal of reusable wares, recyclables, and trash.

(f) Due care and caution must be utilized at all times while driving any Motor Vehicle, and any Trailer attached thereto, on the beach. All vehicles while entering or exiting the beach regardless of the location shall come to a complete stop and yield full right of way to pedestrians, bicyclists, and others on the Beachwalk.

(g) Prior to entering the beach and at all times while on the beach, drivers must turn on their Motor Vehicle's headlights and front and rear flashers and their Trailer's rear flashers, to the extent that the Motor Vehicle or Trailer is so equipped.

(h) Both the passenger and driver's side front windows of the Motor Vehicle shall be rolled down while operating said Motor Vehicle on the beach.

(i) All Motor Vehicles and any Trailers attached there to, shall stay west of the garbage can line on the hard-packed sand or within the vehicle service lane when travelling north and south, and shall travel only north or south on the beach except to the limited extent necessary for brief periods to deploy, service, or remove anything necessary for the Concessionaire to conduct its operations. All Vehicles, and any Trailers attached thereto, entering the area east of the garbage cans shall travel in a ninety-degree angle to the garbage can line. Notwithstanding, all Motor Vehicles shall at all times remain west of all Concession Facilities and other beach equipment (e.g., chairs, umbrellas). The only exception to this rule is for Beachfront Concessions that have been authorized to conduct watersports activities and are in the process of deploying, servicing, or removing watersports equipment from the Concession Area. Said deployment, servicing, or removal of water sports equipment must be conducted with no less than one additional Concessionaire employee who will be positioned on the beachfront to directly supervise and guide said deployment, service, or removal operation, to ensure the safety of the public. Additionally, during any deployment, service, or removal operation, the Concessionaire is required to place no less than eight (8), eighteen-inch (18") high cones, orange in color, no less than four (4) on the northernmost boundary and no less than four (4) on the southernmost boundary of the projected path (from hard-packed sand to the shoreline) of the Motor Vehicle to create a clear non-obstructed path perpendicular to the shoreline, of no less than twenty-five feet (25 ') in width (when measured from north to south). The vehicle driver and a supervising Concessionaire employee must

independently inspect the vehicle perimeter, surrounding area, and path (once marked) before starting the engine, to assure a clear path of ingress to the shoreline or egress to the hard packed sand, and only then, proceed with the respective operation with extreme caution to ensure the safety of all beachfront patrons and persons and property on the beach.

(j) Use of a cellular phone or any other electronic device by the driver while the Motor Vehicle is in motion is prohibited. The Motor Vehicle's gear shift must be placed in the 'park' position and the emergency break engaged prior to any use of a cellular telephone or any other electronic device by the driver.

(k) Concessionaires, their employees, and contractors, are prohibited from driving their personal vehicles on the beach at any time, irrespective of whether the personal vehicle is a motor vehicle or any other type of vehicle (e.g., motorcycle).

(l) Any Motor Vehicle not reflected in an approved Beachfront Concession "Vehicle Information Sheet," and/or not approved by the City, will be required to leave the beach immediately.

(m) Motor Vehicles and Trailers shall not be parked or left unattended on the beach, at time or for any reason, except that golf carts and ATVs shall be permitted to park immediately east of the dune for no more than 30 minutes, but only during the Operating Hours of the Concessionaire and only to the extent that the emergency vehicle path remains unobstructed.

(n) Each driver shall be required by the Concessionaire to drive with both hands on the steering wheel at all times.

(o) Each driver shall be required by the Concessionaire to hold at all times a valid and effective Florida chauffeur's or driver's license (whichever the law may require) which is not suspended or revoked.

(p) Each driver shall be required by the Concessionaire to drive at all times without being under the influence of alcohol, drugs, or any substance which may impair the Driver's ability to drive safely.

(q) Each driver shall be required by the Concessionaire, before the Driver begins his her work for the Concessionaire, to complete a one-hour training course on the or operation of a Motor Vehicle in compliance with the Safe Driving Agreement. The training shall include actual operation by the Driver of the type of Motor Vehicle which the Driver is expected to drive.

15. ENFORCEMENT, PENALTIES AND TERMINATION.

These Rules and Regulations shall be enforced by the City, as set forth below:

(a) The following monetary penalties shall be imposed for a failure to comply with these Rules and Regulations:

- (1) First offense... a penalty of \$250.00.
- (2) Second offense for the same violation within a 12-month period... a penalty of \$500.00.
- (3) Third offense for the same violation within a 12-month period... a penalty of \$1,000.00.

- (4) Fourth offense and subsequent offenses for the same violation within a 12-month period a penalty of ~~\$1,500~~ \$2,500.00.

The City may issue a written warning for first time violations in lieu of a first offense violation. Such penalties are in addition to and separate from any violations issued by the City for noncompliance with other sections of the City Code.

(b) The City Manager, or his/her designee, through its Beachfront Field Supervisor, or other designee, shall enforce the provisions of these Rules and Regulations. As used in these Rules and Regulations, "Field Supervisor" shall include, but not be limited to, a Code Compliance Officer, Park Ranger, a Police Officer or the Beachfront Field Supervisor. If a Field Supervisor finds a violation of this section, the Field Supervisor may issue a Notice of Violation to the violator. The Notice of Violation shall inform the violator of the nature of the violation, amount of penalty for which the violator is liable, and instructions and due date for correcting the violation and for paying the penalty.

(c) If a Concessionaire, or any of its employees or independent contractors, is the named violator, and after issuance of the Notice of Violation, the Concessionaire fails to pay the penalty within ten (10) days, the Beachfront Concession may be revoked by the City Manager.

(d) The City reserves the right to suspend or revoke a Concessionaire's authorization to operate the Beachfront Concession upon the occurrence of the following two conditions:

- (1) a Concessionaire, or any of its employees or independent contractors, is the named violator, in any Notice of Violation of these Rules and Regulations; and
- (2) the Concessionaire, within ten (10) days after issuance of the Notice of Violation, fails to pay the applicable fine or
- (3) the subject Concessionaire has received a total of Eight (8) notices of violation at one property regardless of reason, during the previous Twelve (12) month period.

THE SUSPENSION OR REVOCATION SHALL BE EFFECTIVE TEN (10) DAYS AFTER THE CITY SENDS WRITTEN NOTICE THEREOF TO THE CONCESSIONAIRE; PROVIDED, HOWEVER, THAT THE CITY MANAGER OR HIS/HER DESIGNEE MAY ORDER THE SUSPENSION OR REVOCATION TO BE EFFECTIVE AT ANY EARLIER TIME, INCLUDING THE TIME AT WHICH THE NOTICE OF VIOLATION IS ISSUED, IF THE CITY MANAGER OR THE CITY MANAGER'S DESIGNEE, IN HIS/HER SOLE DISCRETION, MAKES A DETERMINATION THAT THE CONTINUED OPERATION OF THE BEACHFRONT CONCESSION IS A DANGER TO PUBLIC HEALTH, WELFARE OR SAFETY.

(e) A notice sent to a Concessionaire of suspension or revocation, irrespective of when sent, shall state the reason (s) for the suspension or revocation.

(f) ALL BEACHFRONT CONCESSION PERMITS OR AGREEMENTS TO OPERATE BEACHFRONT CONCESSIONS ARE GRANTED ON A REVOCABLE BASIS. THE CITY MAY, THROUGH ITS CITY MANAGER, AND FOR ITS CONVENIENCE AND WITHOUT CAUSE, TERMINATE ANY AUTHORIZATION, PERMIT OR AGREEMENT AT ANY TIME, BY GIVING CONCESSIONAIRE THIRTY (30) DAYS WRITTEN NOTICE OF SUCH TERMINATION.

(g) Following revocation or termination of the authorization, permit or agreement, the City shall

be discharged from any and all liabilities, duties, and terms arising out of, or by virtue of, the authorization, permit or agreement.

(h) Anyone found operating on the beach without the required licenses and approvals will be removed from the beach and will not be allowed to apply for a Beachfront Concession for twelve (12) months thereafter.

15. BEACHFRONT CONCESSION DESIGN STANDARDS

A. Storage Boxes

- (1) Storage Boxes shall be equipped to be fully mobile via trailer or other towing mechanism incorporated internally, for immediate removal from the beach upon demand by the City, or in cases of mandatory emergency evacuation. Skids shall not be used if the Storage Boxes are to be towed.
- (2) Plans for Concession Huts and Storage Boxes shall include accurate dimensions and scale.
- (3) Storage Boxes shall be designed for the horizontal storage of chaise lounge pads, umbrellas, sun canopies, daybeds, and similar items and shall not exceed a maximum size of eight feet (8'-0") in length, eight feet (8'-0") in width and an overall height of eight feet (8'-0") above the sand.
- (4) Storage Boxes shall be simply designed and detailed in a manner appropriate to the unique beach environment inclusive of construction materials and finishes and shall be painted in a neutral or white color with or without an accent trim color and shall be subject to the review and approval of the Design Review Process or other designated City staff.
- (5) No signage shall be permitted on storage facilities, except prominently displayed plaque facing the interior of the Workable Concession Area measuring twelve inches by eighteen inches (12" H x 18' W'), stating "BEACH OPEN TO THE PUBLIC" and the applicable rates for Beachfront Concession services, as well as a discreetly displayed plaque measuring four inches by six inches (4" x 6"), identifying the Concessionaire's name, address and telephone number.
- (6) The size of all of the Storage Boxes shall be included towards the overall percentage (%) allowed within the Workable Concession Area.

B. Concession Huts

- (1) The Concession Huts, which are used to distribute beach furnishings and towels, shall prominently displayed the signage "BEACH OPEN TO THE PUBLIC" on the north, south, and east faces of the hut in a manner not to be concealed by Beachgoers, an open door or window shutter or flap. Concession Huts shall be for the rental of beach equipment, and/or watersports, and/or the sale or distribution of food and/or beverages (non-alcoholic beverages only).

- (2) Concession Huts shall have a maximum floor area of one-hundred (100) square feet, excluding any platform, with exterior dimensions not to exceed 10 feet (10') in width, depth, or length and nine feet (9'-0") in height from the sand to the eave line (i.e., the intersection of the roof and the exterior walls).
- (3) Any architectural projections above the eave line may not exceed twelve feet (12'-0") in height from the sand (i.e., roof and roof related architectural elements), with the exception of poles or masts for signage banner/ pennants attached to the facility, which shall not exceed eighteen feet (18'- 0") in height from the sand.
- (4) All roofing elements shall be appropriate to and consistent with the unique beach environment and/or evocative of the upland architecture and shall be subject to the review and approval of Design Review or other designated staff.
- (5) All Concession Huts shall be designed to preserve vistas and shall be fully open from forty-two (42") inches above the finished floor deck to a minimum eight feet (8'-0") above the sand, with the exception of structural columns or posts
- (6) Any security side panels that may be used as shade devices shall be fully supported from the structure itself and shall not contain independent vertical support columns that extend directly to the sand or perimeter platform walkway.
- (7) A detached perimeter platform walkway, no greater than 40" in width, shall be permitted to surround the concession stand.
- (8) All building construction materials and finishes shall be appropriate to and consistent with the unique beach environment, subject to the review and approval of the Design Review Process or other designated City staff.
- (9) All Concession Huts shall be designed so as to facilitate their immediate removal from the beach at the end of each day, or removal upon demand by the City.
- (10) Signage shall consist of only a fabric banner/ pennant only, which may be attached either to a single mast or span between two (2) poles which are directly attached to the structure itself. The size of the banner/ pennant shall not exceed ten (10) square feet. The overall dimensions, wording, color, placement, design, and mounting systems for said banner/ pennant shall be subject to the review and approval of Design Review Process or designated City staff. The wording on the banner shall be generally limited to the name of the Upland Owner Concessionaire or the primary establishment service.
- (11) Exterior surface colors and finishes shall be appropriate to the design of the structure, as well as the surrounding beach environment, subject to the review and approval of the Design Review Process or other designated staff.
- (12) The size of the Concession Huts shall be included in the overall percentage

(%) allowed within the Workable Concession Area.

- (13) Towel bins, not to exceed 42" in height, may be permitted adjacent to the Concession Huts for the containment of disposed towels. Such bins shall be of a wood finish and painted white to differentiate the bins from trash receptacles.

C. Design and Layout Restrictions

- (1) Umbrella Signage: shall be restricted to the valance area with letters no more than 3" in height and copy limited to the name of the Upland Property and/or the Third-Party Concession Operator, and on the top face of the umbrella the logo of either the Upland Property or the Third-Party Concession Operator.
- (2) **Umbrellas will not be deployed and/or will be folded down and wrapped securely when wind and/or gust forecasts reach Seventeen (17) miles per hour.**
- (3) Sun Canopies: shall be restricted to the area west of the lifeguard stands and shall not exceed 4'-0" in height above the sand.
- (4) Seating areas inclusive of tables and chairs shall not be permitted in or around any of the beachfront structures, with the exception of chairs for the use of guardians of children in the children's sand play areas and for the use of the operator to any watersport activities.
- (5) Small stacking side tables with low-lying profiles, no greater than 16" in height, associated with the distribution of food and /or beverages shall be permitted and shall be contained in the Storage Boxes at day's end.
- (6) Children's sand play areas shall remain free of structures with the exception of shade umbrellas and chairs for the use of guardians.
- (7) In no instance shall serving trays, coolers, boxes, or other devices or objects remain stacked or stored outside of a storage facility and visible from any vantage point on the beach, at any time.
- (8) All battery powered and mechanical equipment shall be concealed to the greatest extent possible and not exposed or remain on vehicular trailer.
- (9) All beach furniture shall be subject to approval by the Design Review Process or other designated City staff.

D. MOBILE COOKING CONCESSION FACILITIES

(1) General Restrictions

- (1) The size of a Mobile Cooking Concession Facility shall be restricted to a minimum size of 8.5' x 10' to a maximum size of 8.5' x ~~20'~~ **32'**. The maximum height of the body of a Mobile Cooking Concession Facility shall be no greater than 8' in height (container height). The suspension, tires, and wheel size of the Mobile Cooking

Concession Facility must all be of a height, width, and size sufficient to raise the Mobile Cooking Concession Facility frame above the sand. A Mobile Cooking Concession Facility which drags or plows the sand due to insufficient elevation will not be permitted.

(2) All Mobile Cooking Concession Facilities must be driven onto the sand each day and removed each evening by a single on-road vehicle of sufficient size, horsepower, and towing capability to accomplish the delivery to and removal from the beach independently and without the assistance of any other vehicle or means. No Mobile cooking and/or heating Concession Facility manufactured Ten (10) or more years prior shall be permitted to operate on the beachfront.

- (3) All battery power, solar panel, and other mechanical equipment shall be concealed to the greatest extent possible and not exposed or adjacent to a Mobile Cooking Concession Facility.
- (4) Any security side panels or sun awnings, attached to or independent from the Mobile Cooking Concession Facility, that may be used as shading devices shall be fully supported from the structure itself and shall not contain independent vertical support columns that extend directly to the sand.
- (5) In no instance shall serving trays, coolers, boxes, or other devices or objects remain stacked or stored outside of a Mobile Cooking Concession Facility and visible from any vantage point on the beach.
- (6) In no instance shall menus, handbills, adverts, flyers, promotions, or other paper or other disposable objects be distributed, remain stacked on/or stored outside of a Mobile Cooking Concession Facility.
- (7) All ancillary furniture, equipment, and embellishments, independent from the Food and Beverage Concession Trailers shall be subject to the Design Review Process or other designated City staff, including tables, chairs, and umbrellas.

(2) EXTERIOR STANDARDS

- (1) Plans and elevations for Mobile Cooking Concession Facilities should include accurate dimensions and scale.
- (2) In general, all Mobile Cooking Concession Facilities signage, exterior copy and graphic imagery shall be encouraged to be creative and artistic.
- (3) Exterior surface colors and finishes shall be appropriate to the design of the Mobile Cooking Concession Facilities and compatible with the unique beach environment and/or evocative of the upland architecture, subject to review and approval through the Design Review Process and/or other designated City staff.
- (4) Color samples of every color to be used (except white), keyed to the four (4) Mobile Cooking Concession Facility elevations. No primary or vibrant color(s) shall be permitted; a muted, light, pale, or pastel color palette is highly encouraged with white as a contrasting color.
- (5) Highly reflective finish and material or chrome-like veneer, shall be prohibited on

any Mobile Cooking Concession Facility.

- (6) Photographic or hyper realistic imagery shall be permitted along the exterior of the Mobile Cooking Concession Facility.
- (7) Line art and graphic imagery may occupy 100 % of the Mobile Cooking Concession Facility.
- (8) Mobile Cooking Concession Facility signage shall be limited to one sign per long side of the Mobile Cooking Concession Facility. The signage shall be limited to identifying the Concessionaire's upland kitchen /hotel, the name of the Mobile Cooking Concession Facility, and any product names. The total square footage per side shall not exceed 20 square feet. Signage lettering shall not exceed 12" in height and shall be subject to the review and approval by the Design Review Process and/or other designated City staff.
- (9) No portion of a sign shall extend above the Mobile Cooking Concession Facility roofline. Any architectural projections or Mobile Cooking Concession Facility "toppers" above the Mobile Cooking Concession Facility roofline may not exceed two feet (2'-0") in height from the Mobile Cooking Concession Facility roof. All roofing elements shall be appropriate to and consistent with the unique beach environment and/or evocative of the upland architecture and shall be subject to review and approval through the Design Review Process and/or other designated City staff.
- (10) No paper signs, streamers, or flags may be attached to the exterior of the Mobile Cooking Concession Facility. One menu, limited to an area of three-square feet, may be affixed to the exterior of the Mobile Cooking Concession Facility.
- (11) General advertising of any format, including displayed commercial products, is prohibited along the exterior of the Mobile Cooking Concession Facility.
- (12) The State of Florida Department of Environmental Protection reserves the right to review and permit all structures, including Concession Huts, Storage Boxes, and Mobile Cooking Concession Facilities, pursuant to Section 161.56 of the Florida Statutes.

THIS PAGE IS INTENTIONALLY LEFT BLANK

DRAFT

APPLICATION REQUIREMENTS

Enclosed herewith is a copy of the most current *Rules and Regulations for Beachfront Concession Operations* and *Application for Beachfront Concession Operations* which must be submitted and approved by the City Manager or the City Manager's designee prior to the operation of any Beachfront Concession. Carefully review the documents and familiarize yourself with their contents. Please ensure that:

- 1) All required signatures are obtained and notarized.
- 2) All required certificate(s) of insurance is (are) provided.
- 3) Evacuation Plan is fully completed.
- 4) Operational Plan is fully completed, including the number of chairs, equipment, etc. which you are requesting to place on the beach.
- 5) Beachfront Concession Layout (drawing) of your operation, including the dimensions of the beachfront area that you intend to use, is specific.
- 6) All regulatory approvals and legal requirements in connection with the operation of the Beachfront Concession including, without limitation, review and approval by the City's Planning Department (Design Review Process) for the Beachfront Concession Facilities which will be placed on the Concession Area.
- 7) In the event there is an existing authorized and properly licensed watersport operation and Applicant desires to continue operating said service, Applicant will be required to submit a new application, with all the required documentation and approvals, for consideration by the City.

Please submit all applications via e-mail to: Jose Catusus at josecatusus@miamibeachfl.gov

Once your application is reviewed and approved, a permit authorization letter will be forwarded to you for execution. Once executed and returned to the City, final authorization will be granted,

Operation of any beachfront business without proper authorization and/or permit, including but not limited to required agreements, contracts, business tax receipt (s), insurance, approved evacuation and operation plans, and Planning Department permits and/or authorizations which may be required, will not be permitted.

ANY BEACHFRONT BUSINESS FOUND TO BE OPERATING WITHOUT CITY AUTHORIZATION SHALL BE CONSIDERED TO BE TRESPASSING AND WILL BE REMOVED FROM THE BEACH AND ANY EQUIPMENT WILL BE CONFISCATED AT CONCESSIONAIRE'S SOLE EXPENSE.

APPLICATION FOR BEACHFRONT

CONCESSION OPERATIONS

{As amended March 2024}

SECTION 1 LOCATION OF CONCESSION REQUESTED

Upland Property Name:

Upland Property Address:

Name of Upland Owner:

SECTION 2 TYPE OF CONCESSION(S) REQUESTED

SELECT ALL CONCESSION TYPES DESIRED BY THE UPLAND PROPERTY

- Commercial – **(For the Public, Residents and Guests with Resort or other fees charged)**
- Non-Commercial – **(No Fees Charged, For Residents and Guests at No Fee)**
- Food and non-alcoholic beverages – prepared and served by the upland property.
*Cooking and heating will only be permitted at those facilities/locations where cooking and heating activities have **been authorized pursuant to a Beachfront Concession permit.***
- Beach Furnishings Rental (Beach chairs, chair pads, umbrellas, cabanas, day beds)
- Watersports - Jet Ski Rentals and In-Water Towable
(Only available through City authorized water channels)
- Parasail – (Only available through City authorized water channels)
- Mobil Cooking Concession Facility - \$10,000 Monthly / \$120,000 Annually

SECTION 3

UPLAND PROPERTY APPLICANT INFORMATION

Name of Property:

(i.e.: Corporation, Panners1ip, LLC, other)

Name of Authorized Representative:

Title of Authorized

Principal Business Address:

Email:

Office Telephone No.:

Authorized Representative Cell Phone Number:

Board of Directors Positions held and E-Mail

President:

Vice President:

Secretary:

Treasurer:

Each document required must be attached.

Please List Your Attachments:

1. MDC Property Appraiser, Folio Listing
2. SOF, Div. of Corporations, SUNBIZ
3. Certificate of Insurance
4. Certificates of Insurance (COI) from each Third-Party concessionaire and each additional property

Beachfront Concession Design Guidelines

BEACH CONCESSION DESIGN GUIDELINES

Concession Hut

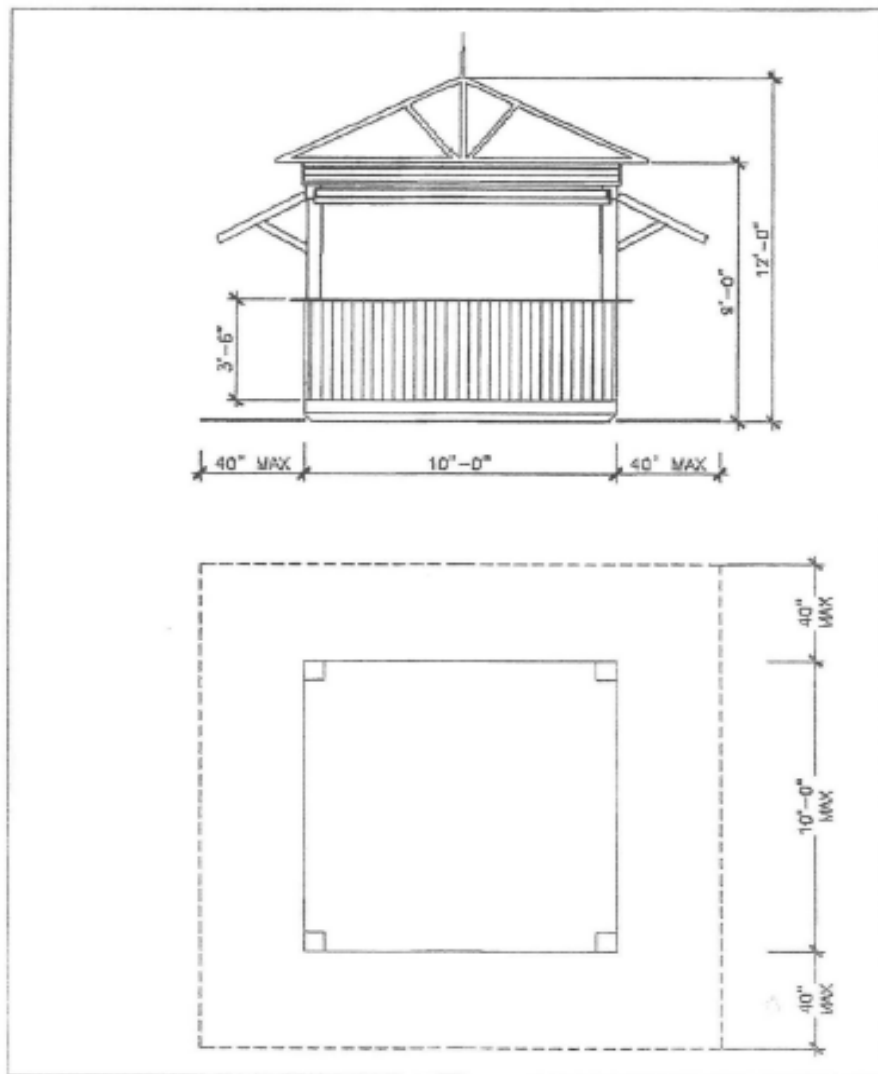

Beachfront Concession Design Guidelines

Large Storage Box

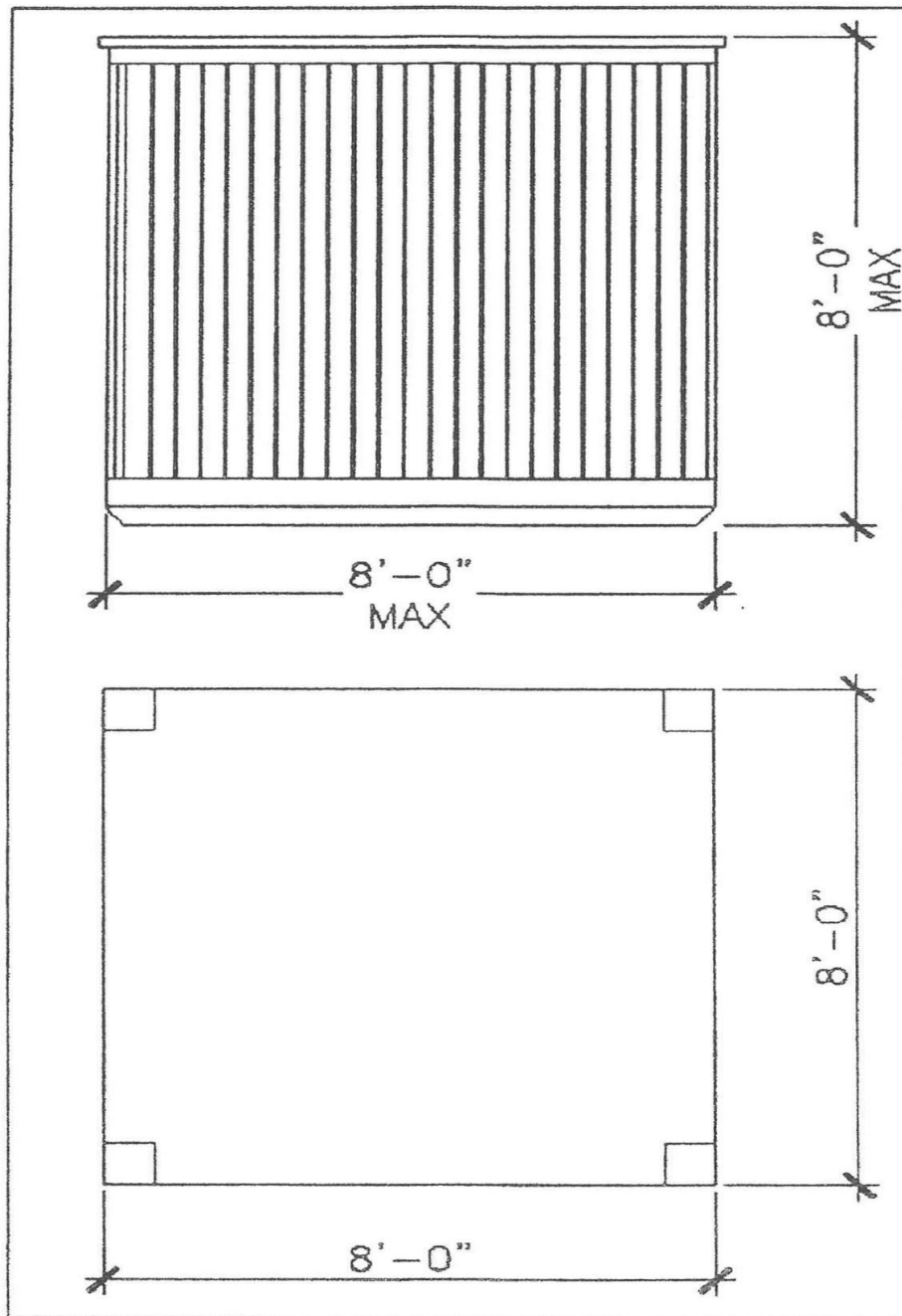

Beachfront Concession Design Guidelines

Small Storage Box

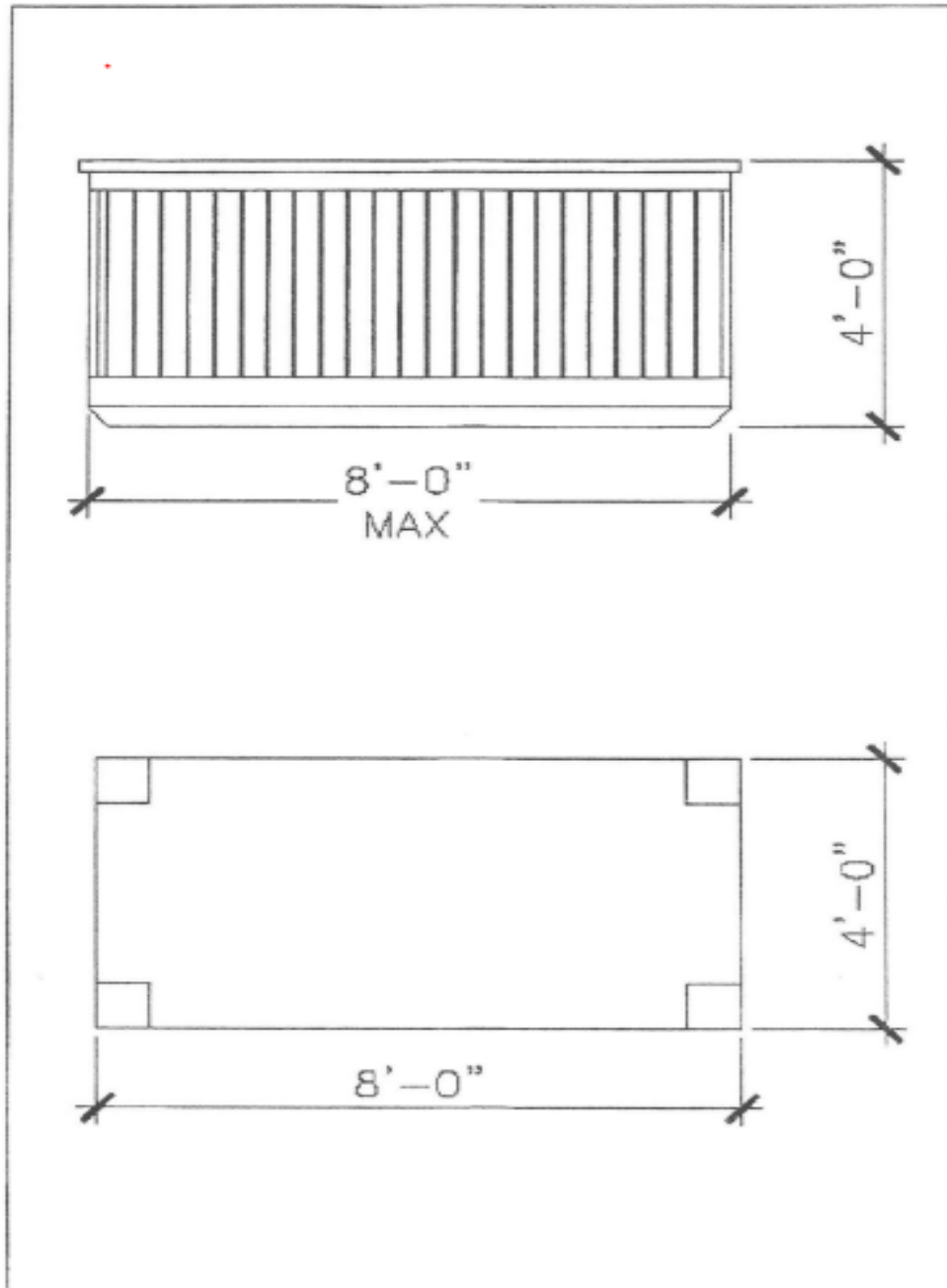

Beachfront Concession Design Guidelines

BEACH CONCESSION LAYOUT

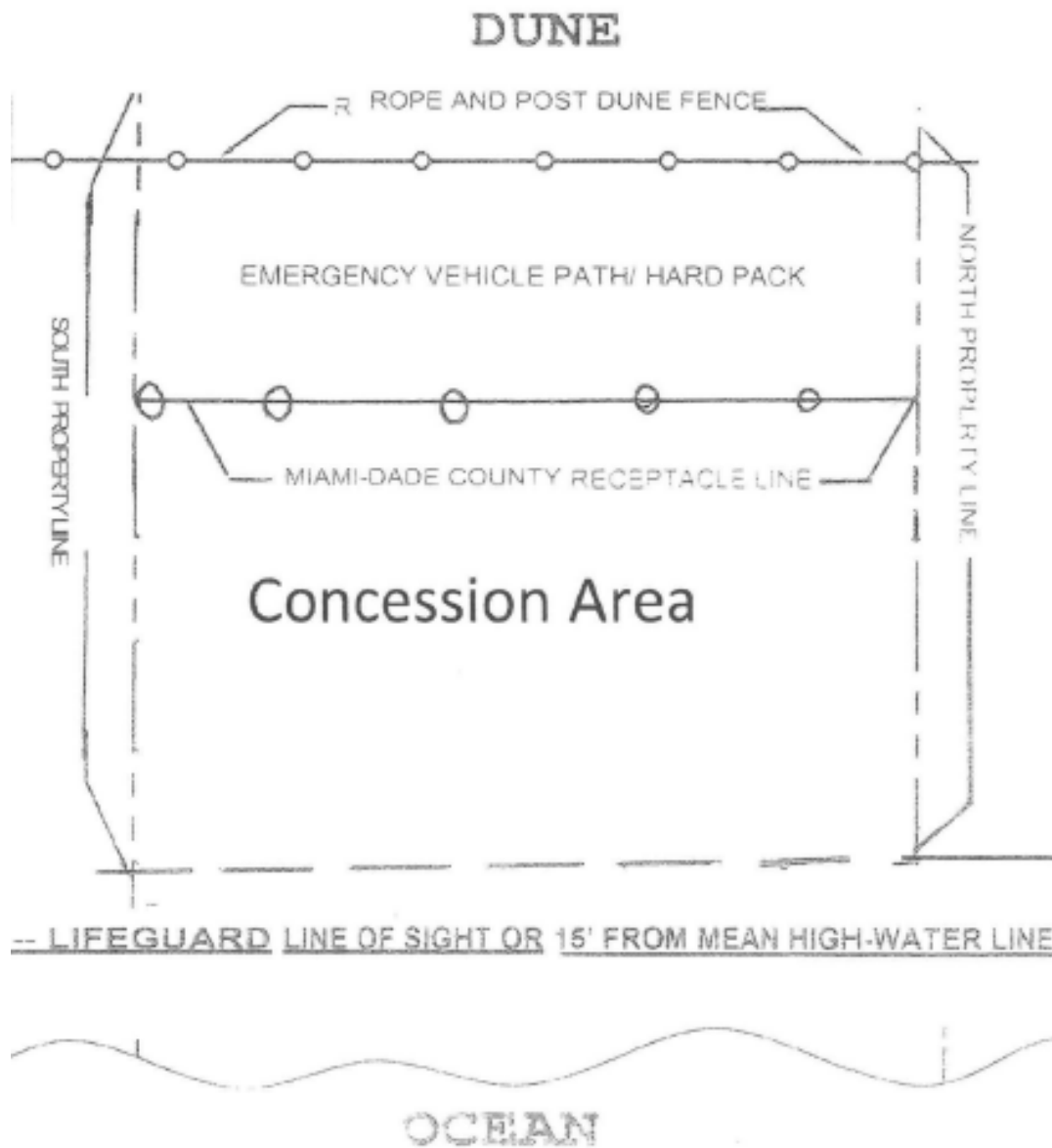

Beachfront Concession Design Guidelines

Heating and/or Cooking Trailers

10' - - 32'

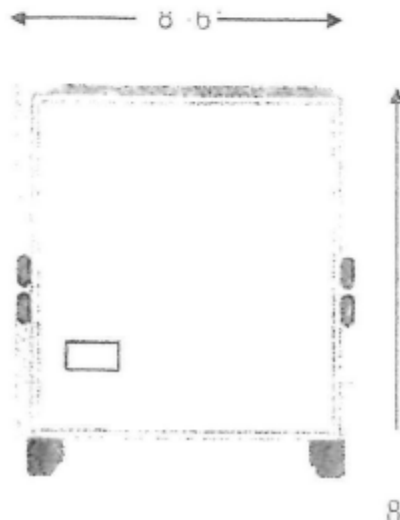

RATE AND FEE SCHEDULES FOR UPLAND OWNER CONCESSIONAIRES

All Upland Owner Concessionaires are subject to an annual upland fee. The annual upland fee is per upland unit for each Upland Property and will increase annually based on the Consumer Price Index (CPI) of the preceding Twelve (12) months as determined by the U. S. Department of Labor Statistics. A maximum upland unit fee will be established also to be adjusted annually based on the Consumer Price Index (CPI) of the preceding Twelve (12) months as determined by the U. S. Department of Labor Statistics and will be applicable to the Upland Property only. The upland unit fee associated with any additional properties are not to be included in association with determining the maximum upland unit fee. The upland unit fee and additional property unit fee will be required for each Beachfront Concession location, plus any applicable taxes and the activity fee for each Concession activity, such as beach furnishings rental, Food and Beverage beach service, and beachfront watersports rentals and parasailing if so approved. All tax receipts and upland fees shall be due and payable prior to October 1st of the fiscal year.

Any required City Business Tax Receipt must be obtained prior to beginning any Beachfront Concession operation. The available Beachfront Concession categories are listed below. The fees shall be increased annually based on the Consumer Price Index (CPI). Authorization for Mobile Cooking Concession Facility (commonly known as Food Trucks) require specific authorization pursuant to the Beachfront Concession permit at a fee, payable in advance, of ten thousand dollars (\$10,000) per month (in addition to fees associated with a City Business Tax Receipt for Food and Beverage, and specific standards for the construction of Mobile Cooking Concession Facilities and their appliances and power source, as detailed below.

2023 - 2024

Permit Fees Associated with Beach Front Concessions

1. Upland Unit Fee – \$ 30 / Unit Maximum Cap for 2023 – 2024 - \$ 20,084
2. Additional Property Fee - \$ 30 / Unit
3. Beach Furnishings – \$ 1,065
4. Water Sports – \$ 1,065
New Requests – Must be presented to the Waterfront Protection Authority for consideration and approval followed by the approval of the City Manager
5. Food and Non-Alcoholic Beverage Service – \$ 1,065
(Service from Upland Property)
6. Parasail – Existing – \$ 1,065
New Requests – Must be presented to the Waterfront Protection Authority for consideration and that approval followed by the approval of the City Manager.
7. Mobile Cooking Concession Facility - \$10,000 Monthly / \$120,000 Annually

**UPLAND PROPERTY CONCESSIONAIRE
AND THIRD-PARTY CONCESSIONAIRE
ACKNOWLEDGEMENT AND AUTHORIZATION**

Page 1 of 2

I have read and understand the attached Rules and Regulations for Beachfront Concession operations and agree to be bound by the terms and conditions contained herein. I agree that I will be responsible to the City for the operation of the Beachfront Concession in accordance with the terms and conditions of the Rules and Regulations, even in the event that a Third-Party Concession Operator is approved by the City to operate all or a portion of the Beachfront Concession. My obligations, associated with the operation of the Beachfront Concession, shall include, without limitation, any financial obligations, such as paying for any required occupational licenses, all permits, fees, fines, and penalties, and satisfying any liens which may be imposed related to the Beachfront Concession. As such, I also agree to ensure that any approved Third-Party Concession Operator complies with the requirements set forth in the Rules and Regulations for Beachfront Concession including, without limitation, maintaining the required Beachfront Concession insurance, abiding by the Beachfront Concession Rules and Regulations which may be amended from time to time, and if the permit provides for Food and Beverage service, maintaining a Food Service license issued by the Florida Department of Business and Professional Regulation – Division of Hotels and Restaurants for the food service unit. I further agree to provide any documentation or other information which may be requested by the City in connection with the Beachfront Concession.

I further agree to notify the City, thirty (30) days prior to any sale or transfer in the interest of the Upland Owner Concessionaire or in the Third-Party Concession Operator entity. The successor entity shall be required to apply for its own Beachfront Concession permit in accordance with the terms and conditions of the Rules and Regulations.

I FURTHER ACKNOWLEDGE THAT ALL BEACHFRONT CONCESSION AUTHORIZATIONS, PERMITS OR AGREEMENTS TO OPERATE BEACHFRONT CONCESSIONS ARE GRANTED ON A REVOCABLE BASIS. THE CITY MAY, THROUGH ITS CITY MANAGER, AND FOR ITS CONVENIENCE AND WITHOUT CAUSE, TERMINATE ANY AUTHORIZATION, PERMIT OR AGREEMENT AT ANY TIME BY GIVING CONCESSIONAIRE THIRTY (30) DAYS WRITTEN NOTICE OF SUCH TERMINATION. FOLLOWING REVOCATION OR TERMINATION OF THE AUTHORIZATION, PERMIT OR AGREEMENT, THE CITY SHALL BE DISCHARGED FROM ANY AND ALL LIABILITIES, DUTIES, AND TERMS ARISING OUT OF, OR BY VIRTUE OF, THE AUTHORIZATION, PERMIT OR AGREEMENT.

Under penalties of perjury, I affirm that all the Application information I have provided herein is true and correct. I further agree to comply with the aforementioned acknowledgements and terms and conditions. The undersigned signatory warrants and represents that he/she has secured all necessary authorizations from its board to execute this application and acknowledgement. Furthermore, I affirm that the powers and authority granted to me by my official position empower me to execute this Upland Property Concessionaire Acknowledgement and Authorization and will be equally binding on my successors in interest during the term of this permit, subject to the successor entity complying with the application and approval process for the permit within thirty (30) days from the date of the sale or transfer of the Applicant's interest.

THIS ACKNOWLEDGEMENT AND AUTHORIZATION IS SWORN TO, SUBSCRIBED, AND ACKNOWLEDGED ON THE FOLLOWING PAGE BY THE UPLAND PROPERTY AUTHORIZED REPRESENTATIVE AND THE THIRD-PARTY CONCESSION OPERATOR REPRESENTATIVE (IF ANY).

OPERATIONAL PLAN

Please describe your proposed operation including specific numbers and types of equipment (attach a photograph, copy of brochures or other descriptive materials for equipment), number of personnel, and hours of operation (NOTE: The concession is to be open and operating seven days a week, weather permitting). If a water recreational concession attach a sketch illustrating the placement of the Concession Hut and equipment as required in the Rules and Regulations. Information should also include the type and number of beach chairs, type and number of umbrellas, type and number of watercrafts, etc.

QUANTITY

Lounge Chairs	_____
Umbrellas	_____
Sand Chairs	_____
Cabanas	_____
Lg. Storage Shed	_____
Sm. Storage Box	_____
Concession Hut	_____
Food & Beverage Trailer	_____
Mobile Cooking/Heating	_____ (Only in City Approved Locations)
Watersports Equipment	_____ (Only in City approved water channels)
Type	_____
Type	_____
Type	_____
Other Equipment	_____
Other Equipment	_____
Other Equipment	_____
Other Equipment	_____
Other Equipment	_____
Staffing	_____
Hours of Operation	_____

EVACUATION PLAN

Please describe in full detail your evacuation plan in case of a natural disaster such as a hurricane. All your facilities and/or equipment must be off the beach and safely stored at a private, off-site location within one (1) hours' notice given by the City and /or within eight (8) hours of the issuance of a Hurricane Warning by the Miami-Dade County Office of Emergency Management. Identify the storage space, and its location, that you would use in this type of situation.

DRAFT

**Beachfront Concessionaire
Motor Vehicle Information**

Complete ONLY if a Motor Vehicle will be used for this Beachfront Concession.

Specify type of **Motor Vehicle** requested to be used by Concessionaire and if applicable, Third-Party Concession Operator (hereafter referred to as Vehicle).

Vehicle 1:

Vehicle Type: _____

Vehicle Make and Model _____

Vehicle Year; Color and Tag: _____

Vehicle 2 :

Vehicle Type: _____

Vehicle Make and Model _____

Vehicle Year, color, and tag _____

Vehicle 3 :

Vehicle Type: _____

Vehicle Make and Model _____

Vehicle Year, color, and tag _____

ONLY THE ABOVE IDENTIFIED VEHICLES WILL BE DEEMED APPROVED AND CONCESSIONAIRE SHALL NOT USE ANY ADDITIONAL VEHICLE(S) ON THE BEACH. VIOLATION OF THIS REQUIREMENT MAY RESULT IN THE REVOCATION, SUSPENSION AND/OR TERMINATION OF CONCESSIONAIRE'S PERMIT OR AGREEMENT.

Signature of Authorized Upland Owner's Representative DATE

Complete ONLY if a Motor Vehicle will be used for this Beachfront Concession.

As the Concessionaire or Third-Party Concession Operator, I am at all times responsible for the conduct of my staff. To this point, I have read and understand the “Rules for The Operation of a Vehicle on The Beach” and have had each of my staff who do at this time or may in the future have an opportunity or assignment to operate a motor vehicle on the beach, read and acknowledge the understanding of the attached “Rules for The Operation of a Vehicle on The Beach”. I and all my staff and employees are bound by the rules, terms and conditions contained in this agreement.

By my signature below I agree to abide by these rules and ensure that all of my staff agree to abide by them as well at this time and in the future.

The driver hereby accepts, and agrees to comply with, the following rules for his or her driving duties:

- (1) Motor Vehicles shall not be driven faster than 5 M.P.H.
- (2) Motor Vehicles shall be driven only on the hard-packed sand area (between the dunes and the trash cans).
- (3) Driving on the beach shall be kept to a minimum.
- (4) Due care and caution must be utilized at all times while driving any Motor Vehicle, and any Trailer attached thereto, on the beach.
- (5) Prior to entering the beach and at all times while driving on the beach, the Driver will turn on the Motor Vehicle's headlights and front and rear flashers and the Trailer's rear flashers to the extent that the Motor Vehicle or Trailer is so equipped.
- (6) Both the passenger and driver's side front windows of the Motor Vehicle (if equipped with windows) shall be rolled down while operating the Motor Vehicle on the beach.
- (7) All Motor Vehicles, with or without Trailers, shall stay west of the garbage can line on the hard-packed sand when travelling north and south, and shall travel only north or south on the beach except to the limited extent necessary for brief periods to deploy, service, or remove anything necessary for the Concessionaire to conduct its operations.
- (8) During any deployment, service, or removal operation, the Driver will place the Concessionaire-supplied orange cones as follows: at least four cones on the northernmost boundary, and at least four cones on the southernmost boundary, of the projected path (from hard-packed sand to the shoreline) of the Motor Vehicle to create a clear non-obstructed path perpendicular to the shoreline, of no less than twenty-five feet (25') in width (when measured from North to South),
- (9) During any deployment, service, or removal operation of jet skis, the Driver and a supervising Concessionaire employee must independently inspect the Motor Vehicle's perimeter. The entire surrounding area, and path (once marked) shall be inspected for persons and/or objects before starting the engine, to assure a clear path of ingress to the shoreline or egress to the hard packed sand and only then, proceed with the respective operation with extreme caution to ensure the safety of all beachfront patrons and persons and property on the beach.

Complete ONLY if a Motor Vehicle will be used for this Beachfront Concession.

(10) Use of a cellular phone, or any other electronic, electric, or battery-powered device, by the Driver while the Motor Vehicle is in motion is prohibited. The Motor Vehicle 's gear shift must be placed in the "park" position and the emergency break engaged prior to any use of a cellular telephone or any other electronic, electric, or battery-powered Device by the Driver.

(11) The Driver shall drive with both hands on the steering wheel at all times.

(12) The Driver will not park or leave unattended on the beach any Motor Vehicle or Trailer at any time or for any reason, except that golf carts and ATVs are permitted to park immediately east of the dune for no more than 30 minutes; only during normal business hours of the Concessionaire; and only to the extent that the emergency vehicle path on the hard pack of the beach remains unobstructed.

(13) Each driver shall hold a valid and effective Florida chauffeur's or operator's driver's license (whichever the law may require) which is not now suspended or revoked. This fact is to be confirmed by the concessionaire/employer. The employee will maintain this license continuously in The same status throughout the course of their employment.

(14) No driver will drive any Motor Vehicle while under the influence of alcohol, drugs, or any substance which may impair my ability to drive safely. Each driver will immediately advise the Concessionaire of, and will furnish the Concessionaire with, a hard copy of any ticket, summons, citation, or similar document which alleges any such driving irrespective of when or where it occurs.

(15) I will immediately advise my employer (Concessionaire) of any accident which occurs, and will furnish the City and my employer with any requested documents, concerning any accident which occurs while I am driving any Motor Vehicle for the Concessionaire. I have not been advised of any claim, and I am not a party to any lawsuit, arising out of or relating to any type of accident.

(16) I have successfully completed the Concessionaire's one-hour training course on the operation of a Motor Vehicle in compliance with this Safe Driving Agreement. The training included actual operation by me of the type of Motor Vehicle which I am expected to drive on the beach.

Typed or Printed Driver's Name

Driver's Signature:

Date

This form is intended to remain with the employer and produced upon city request.

CERTIFICATION BY CONCESSIONAIRE

Complete ONLY if a Motor Vehicle will be used for this Beachfront Concession.

As the Concessionaire or Third-Party Concession Operator, I am at all times responsible for the conduct of my staff. To this point, I have read and understand the “Rules for The Operation of a Vehicle on The Beach” and have had each of my staff who do at this time or may in the future have an opportunity or assignment to operate a motor vehicle on the beach, read and acknowledge their understanding of the attached “Rules for The Operation of a Vehicle on The Beach”. I and all of my staff are bound by the rules, terms and conditions contained in the preceding pages of this Safe Driving Agreement and the associated “Rules for The Operation of a Vehicle on The Beach”.

By my signature below I agree to abide by these rules and ensure that all of my staff agree to abide by them as well at this time and in the future.

Date and Concessionaire Signature

Typed or Printed Full Corporate Name of Concessionaire

BEACHFRONT CONCESSION INSURANCE

The following is required by the City of Miami Beach with respect to the Beachfront Concession operations, pursuant to Rule 4 of the preceding Rules and Regulations for Beachfront Concession Operations:

Each Direct City Concessionaire, Upland Owner Concessionaire, or Third-Party Concession Operator shall furnish to the City of Miami Beach Risk Management Department a Certificate of Insurance which complies in all respects with the said Rule 4 and with the following:

1. Commercial General Liability limits \$1,000,000.

2. The City of Miami Beach must be listed as a CERTIFICATE HOLDER as follows:

City of Miami Beach
1700 Convention Center Drive
Miami Beach, FL 33139

3. The City of Miami Beach must be named as an ADDITIONAL INSURED.

The following language must be included under the section of Description of Operations/Locations Vehicles/Special Items:

The City of Miami Beach is included as an additional insured with respect to the beachfront concession operations.

4. Worker's Compensation

Companies that employ more than three (3) employees must provide proof of Worker's Compensation insurance; otherwise, please provide a letter on Company letterhead stating that you have three (3) or less employees.

5. All policies must be issued by companies authorized to do business in Florida with a Best Key rating of A-V or better.

6. Each Certificate of Insurance delivered to the City must contain the following provision: A copy of any notice of cancellation, or of any reduction in scope or amount of coverage, shall be sent to the City of Miami Beach at the same time that it is sent to the named insured.

If you have any questions, please feel free to contact the City of Miami Beach Risk Management Department at (305) 673-7014 or the Office of Real Estate at (305) 673-7631.



City of Miami Beach, 1700 Convention Center Drive, Miami Beach, Florida 33139, www.miamibeachfl.gov

Facilities and Fleet Management Department, Beach Maintenance Division
 1833 Bay Road, Miami Beach, FL 33139
 (305) 673-7631

Beachfront Concession Permit Renewal by Letter Form

(NOT TO BE USED FOR 2024 RENEWALS)

May 15, _____

To Upland Owner/Manager:

The City of Miami Beach is currently renewing Beachfront Concession Permits for all Upland Properties for fiscal year October _____ - September _____.

Please refer to the Beachfront Concession Application which you submitted when you applied for your fiscal year _____ Beachfront Concession Permit. If all the information contained on said application is current and accurate, please have the Authorized Representative mark Box #1 and sign below. Include any updated COI and for any new employee, if an operator of a vehicle, their Driver's License.

If all the information contained in your fiscal year _____ Beachfront Concession Application is **NOT** current and accurate, please revise the applicable pages, using the blank application provided, and have the stated Authorized Representative mark Box #2 and sign below.

Please return all documents to the Facilities and Fleet Management Department, Beach Maintenance Division located at 1833 Bay Road, Miami Beach, Florida 33139 (or scan and e-mail to beachfrontconcessionadministration@miamibeachfl.gov no later than June 1, 20___).

Also, attached for your reference is a copy of the Sixth Amended Rules and Regulations, as well as the Application Information and Insurance Requirements for Beachfront Concession operations.

If you have any questions or need further assistance, please contact Beach Maintenance at (305) 673-7631 or via e-mail at beachfrontconcessionadministration@miamibeachfl.gov

- 1. NO CHANGES, All the information contained on my fiscal year 2023/24 Beachfront Concession Application (attached hereto) is current and accurate.
- 2. Please update my existing Beachfront Concession Application (attached hereto) with the attached revised pages.

UPLAND PROPERTY APPLICANT AND AUTHORIZED REPRESENTATIVE

Property Name **Print**

Property Address

Property Owner or Reg. Agent **Print**

Signers Official Position **Print**

Date

Property Owner or Reg. Agent **Signature**

We are committed to providing excellent public service and safety to all who live, work, and play in our vibrant, tropical, historic community.

MIAMIBEACH

City of Miami Beach, 1700 Convention Center Drive, Miami Beach, Florida 33139,
www.miamibeachfl.gov Facilities and Fleet Management, Beach Maintenance Division, 1833
Bay Rd., Miami Beach FL 33139,
Tel: 305-673-7631

BEACHFRONT CONCESSION ADDITIONAL PROPERTY

May 15, 2024

To Upland Owner Concessionaire:

Per Section 3(c) (Business Tax Receipts and Fees) of these Amended and Restated Rules and Regulations For Beachfront Concession Operations, the Upland Property shall pay an Upland Fee based on the number of units contained in the Upland Property (with a maximum adjusted annually). If the Upland Owner Concessionaire requests that the Concession Area be utilized by any additional property or properties, other than the Upland Property, the same Unit fee shall apply to any additional properties based on the number of units in each of the additional properties. The maximum unit fee shall not take into consideration the number of units in additional properties. These fees shall be due and payable in advance to the City's granting authorization for a Beachfront Concession Permit for each fiscal year, and prior to October 1, of each fiscal year.

Be advised that servicing and/or accommodating additional properties at your Beachfront Concession without notifying the City of Miami Beach is a violation of the Rules and Regulations and could result in the revocation of your Beachfront Concession permit.

If there are no additional properties serviced or accommodated at your Beachfront Concession, please have the stated Authorized Representative mark Box #1 and sign below. If any additional properties are being serviced and accommodated at your Beachfront Concession, please have the stated Authorized Representative mark Box #2 and list below all additional properties. The Upland Property owner must also provide a Certificate of Insurance to the City of Miami Beach, with the City named as a Certificate Holder as well as an Additional Insured, from all listed additional properties.

If you have any question, or need further assistance please contact Beach Maintenance at (305) 673-7631 or via e-mail at beachfrontconcessionadministration@miamibeachfl.gov.

- 1. There are no additional properties serviced and/or accommodated at this Upland Property.
- 2. The additional properties serviced and/or accommodated at the concession area seaward of the Upland Property are listed below.

Additional Property Name	Additional Property Address

Authorized Representative

Property Name and Address

Authorized Representative Print Name and Title

Authorized Representative Sign / Date