

**1** MANUEVERABILITY - LOADING  
 SCALE: 1" = 30'-0"

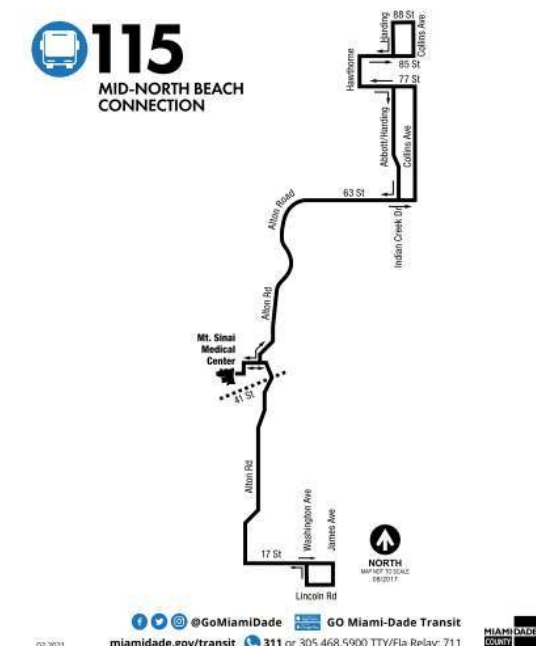

**1** MANUEVERABILITY - PARKING  
SCALE: 1" = 30'-0"



TRANSIT CORRIDOR LOCATION MAP  
SCALE: 1/4" = 1'-0"

BUS ROUTE



CLASS A OFFICE TOWER: 600 BRICKELL  
OFFICE FLOOR TO FLOOR HEIGHT: 13' -6"

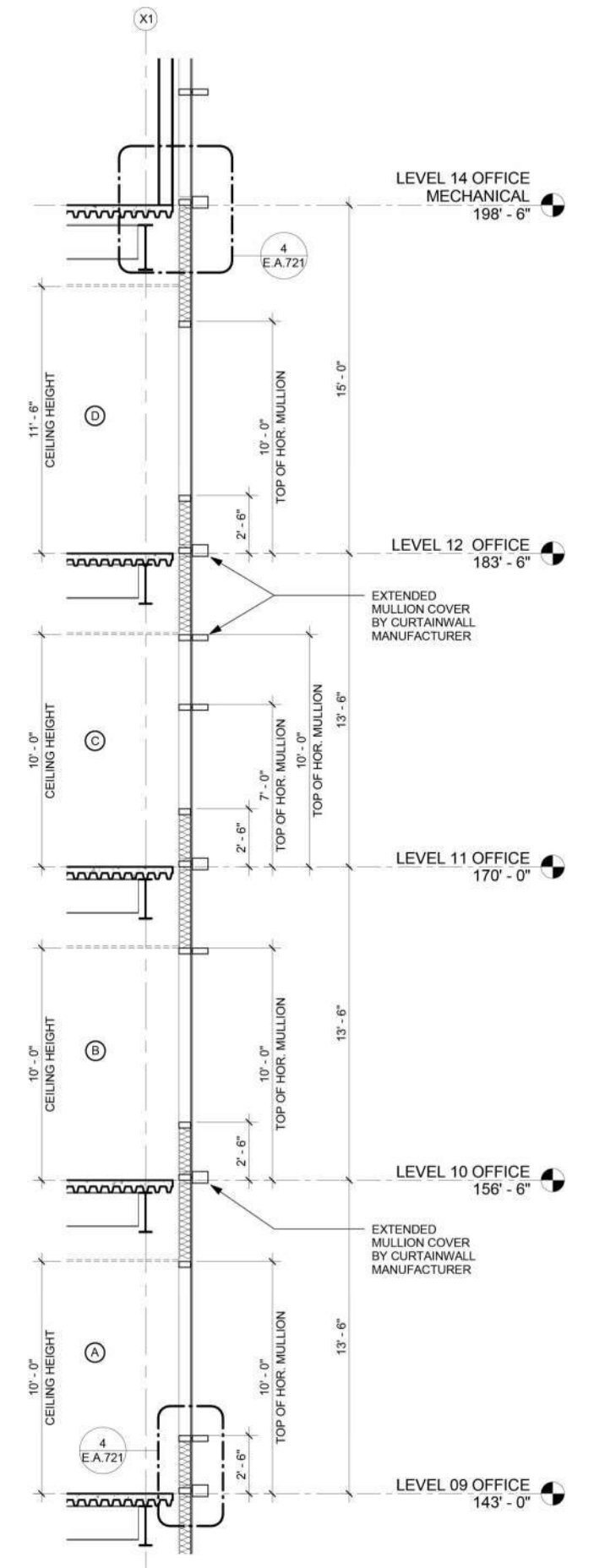



CLASS A OFFICE TOWER: 600 BRICKELL  
 OFFICE FLOOR TO FLOOR HEIGHT: 13' -0"

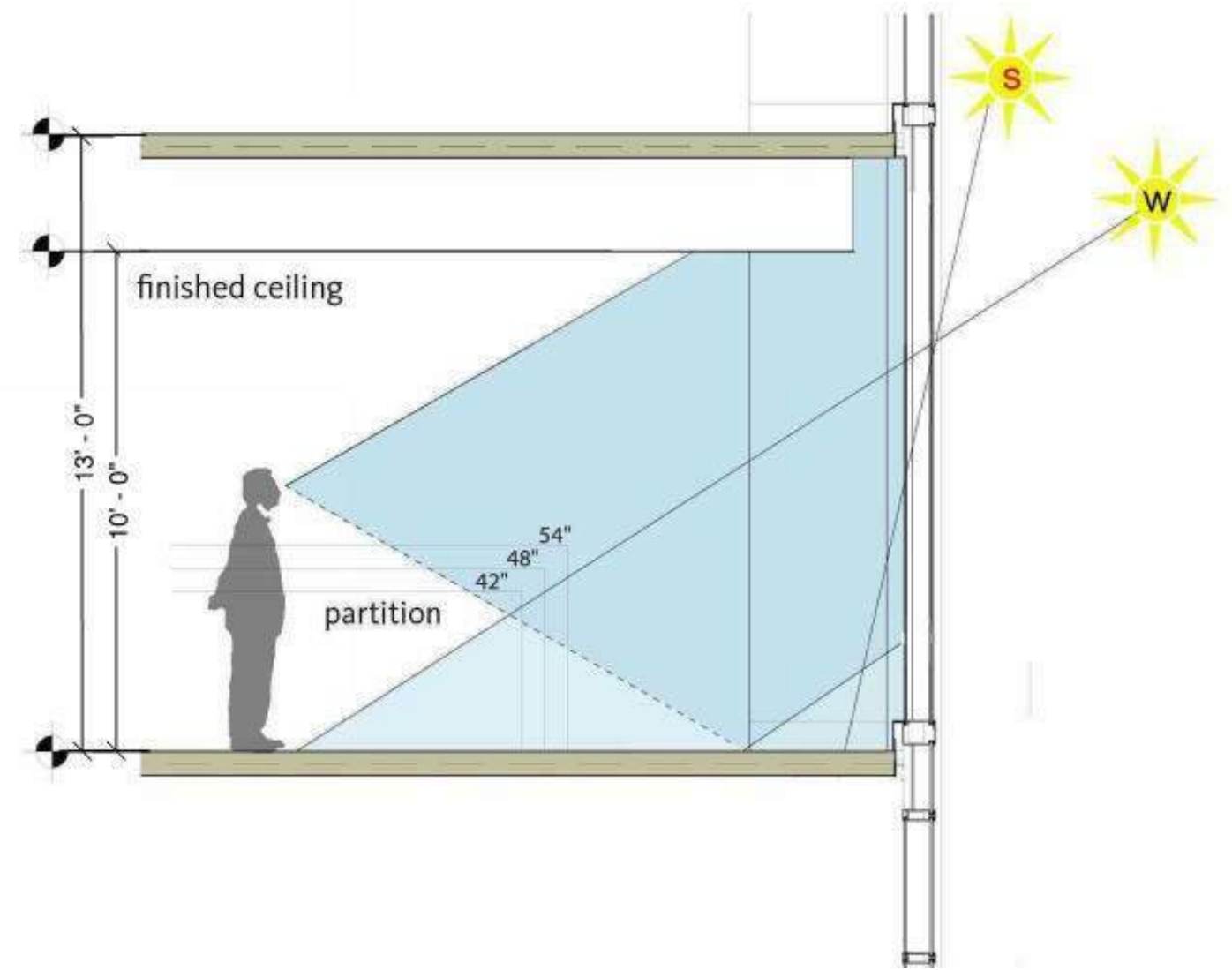



CLASS A OFFICE TOWER: 545 WYN  
 OFFICE FLOOR TO FLOOR HEIGHT: 14' -0"

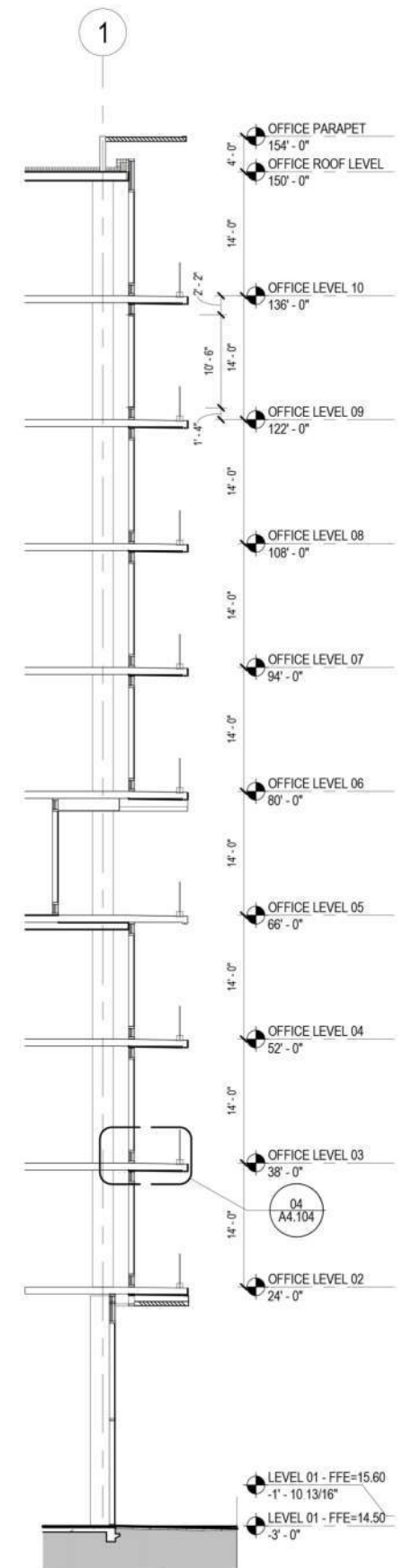



CLASS A OFFICE TOWER: THREE BRICKELL CITY CENTER  
TENANT: AKERMAN  
FLOOR TO FLOOR HEIGHT: 13' - 6"  
FINISHED CEILING HEIGHT: 10'-0"





CLASS A OFFICE TOWER: 600 BRICKELL AVENUE  
TENANT: SITEL  
FLOOR TO FLOOR HEIGHT: 13'-6"  
FINISHED CEILING HEIGHT: 10'-0"

