

**THIS SURVEY**

**LOCATION MAP**  
 LIGHT POLE IN SECTION 22, TOWNSHIP 53 SOUTH, RANGE 42 EAST  
 CITY OF MIAMI BEACH, MIAMI-DADE COUNTY, FLORIDA  
 SCALE: 1" = 300' (SHEET SIZE 24"x36")  
 SCALE: 1" = 600' (SHEET SIZE 11"x17")



**PROPOSED CROWN CASTLE UTILITY NODE FL6432BA**  
 LATITUDE - NORTH 25°48'46.1"  
 LONGITUDE - WEST 80°07'46.1"  
 NORTHING - 538604.402 (Y)  
 EASTING - 942547.739 (X)

- LEGEND**
- CONCRETE
  - CURB & GUTTER
  - CATCH BASIN
  - CONCRETE BLOCK STRUCTURE
  - MIAMI-DADE COUNTY PUBLIC RECORDS
  - STORM DRAINAGE MANHOLE
  - ELECTRIC HANDHOLE
  - ELECTRIC MANHOLE
  - FEDERAL EMERGENCY MANAGEMENT AGENCY
  - GLOBAL POSITIONING SYSTEM
  - IDENTIFICATION
  - IRON PIPE
  - LICENSED BUSINESS
  - LANDSCAPING AREA
  - MANHOLE
  - METAL LIGHT POLE
  - NUMBER
  - OVERHEAD WIRES
  - PLAT BOOK
  - PARKER-KALON
  - SANITARY SEWER MANHOLE
  - TRAFFIC SIGNAL POLE
  - WATER METER
  - WOOD POWER POLE
  - WATER VALVE

- NOTES:**
- This is a Specific Purpose Survey for the stated purpose of locating improvements within a 50' wide radius of the light pole to be used for proposed telecommunications equipment. Client provided the location of the subject light pole.
  - BEARINGS shown hereon are based upon the centerline of West 40th Street with an assumed bearing of S83°10'34"E.
  - Right-of-way widths determined from Plat Book 8 Page 116, Miami-Dade County, Florida, Public Records.
  - Geodetic and Florida State Plane coordinates shown hereon are based on G.P.S. observation using the Florida Permanent Reference Network (FPRN) base station "FLMB". Accuracy within tolerances as set forth by the F.A.A. Referenced to North American Datum 1983, 1990 Adjustment.
  - 2017 Aerial Photograph shown hereon obtained from Florida Department of Transportation
  - All dimensions are shown in feet and decimal feet.
  - No attempt was made by this firm to determine the nature, size, and location of underground utilities. Underground paint mark locations were located at the time of this survey and plotted hereon. Contractor should notify "Sunshine No-Cuts" prior to ANY excavation work. This is not a comprehensive Utility Survey.
  - All documents are recorded in the Public Records of Miami-Dade County, Florida, unless otherwise noted.
  - The lands shown hereon have not been abstracted by this firm regarding matters of interest to other parties, such as easements, rights-of-ways, reservations, etc. A Title Commitment review has not been performed.
  - Roof overhangs, if any, not shown unless otherwise noted.
  - The subject light pole lies in Section 22-53S-42E in the City of Miami Beach, Miami-Dade County, Florida.
  - Right-Of-Way lines do not represent an opinion of ownership by this Firm.
  - Fence and wall ownership is not determined. This survey does not reflect or determine ownership.
  - In some instances graphic representation have been exaggerated to more clearly illustrate the relationship between physical improvements and/or lot lines. Dimensions shall contact the location of the improvements over scaled positions.
  - THIS IS NOT A BOUNDARY SURVEY.

This item has been digitally signed and sealed by Geoffrey Letier, P.S.M. No. 6395 State of Florida, on 7/5/2019 using a Digital Signature.  
 Printed copies of this document are not considered signed and sealed and the SHA authentication code must be verified on any electronic copies.

**FEMA FLOOD ZONE**  
 Community No.: 120651  
 Community Name: City of Miami Beach  
 Panel No.: 0309  
 Suffix: L  
 Map Number: 12086C0309L  
 Flood Zone: AE  
 Base Flood Elevation: 7.0' NGVD  
 Date of Map Panel: 9/11/2011  
 Date of Firm Index: 9/11/2011

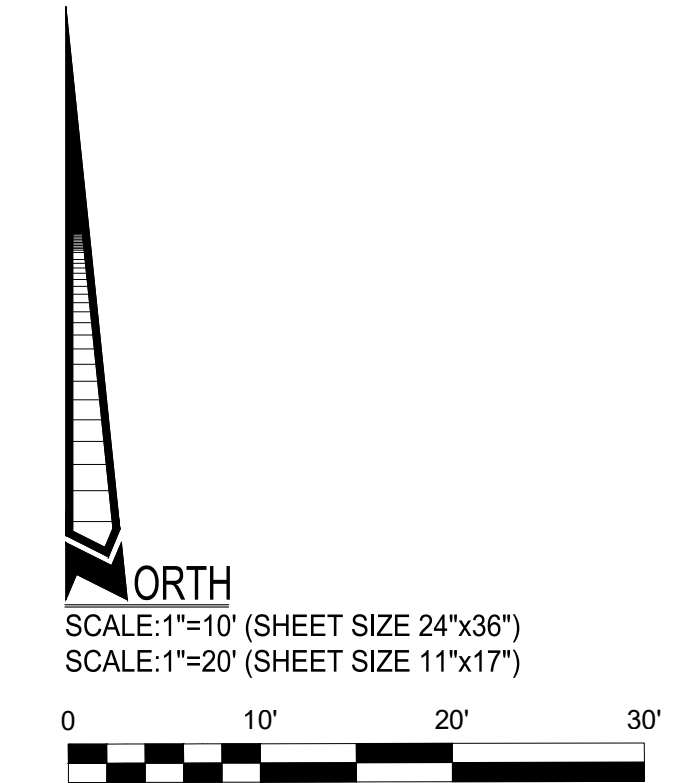

**CROWN CASTLE FL6432BA**  
 NEAR ADDRESS: 3792 ROYAL PALM AVENUE, MIAMI BEACH, FLORIDA 33140

TYPE OF SURVEY: SPECIFIC PURPOSE SURVEY  
 PREPARED FOR: MORRISON HERSHFELD CORP.  
 LETIER PEREZ & ASSOCIATES, INC.  
 LAND DEVELOPMENT CONSULTANTS  
 CIVIL ENGINEERS - LAND SURVEYORS  
 LAND PLANNERS - ENVIRONMENTAL  
 TRANSFERABLE OR ASSIGNABLE  
 520 N.W. 18TH STREET ROAD, SUITE 209, MIAMI, FLORIDA 33169  
 MIAMI-DADE (305) 652-2133 BROWARD (954) 224-2202 FAX: (305) 652-2411  
 WEBSITE: www.letierperez.com LICENSED BUSINESS NO. 6787

DATE	JOB ORDER	DESCRIPTION	F.B.	PG.
09-04-18	18-239			
08-24-18	B-2494			
16-2391.6432BA				
F.B. 351	PG. 39			

**NOTES:**

- ELEVATIONS WHEN SHOWN REFER TO THE NATIONAL GEODETIC VERTICAL DATUM (N.G.V.D.) 1929.
- THIS FIRM HAS MADE NO ATTEMPT TO LOCATE FOOTINGS AND/OR FOUNDATIONS UNLESS OTHERWISE NOTED.
- THE LANDS SHOWN HEREON HAVE NOT BEEN ABSTRACTED BY THIS FIRM REGARDING MATTERS OF INTEREST TO OTHER PARTIES, SUCH AS EASEMENTS, RIGHTS-OF-WAYS, RESERVATIONS, ETC.
- THIS SURVEY WAS PREPARED FOR AND CERTIFIED TO THE PARTY AND/OR PARTIES INDICATED HEREON AND IS NOT TRANSFERABLE OR ASSIGNABLE.
- ALL IRON PIPES & NAILS AND DISCS SET BY THIS FIRM SET WITH CAP OR DISC WITH LEG ETCH.

**SURVEYOR'S CERTIFICATE:**  
 I HEREBY CERTIFY THAT THIS SURVEY IS TRUE AND CORRECT TO THE BEST OF OUR KNOWLEDGE AND BELIEF AS RECENTLY SURVEYED AND DRAWN UNDER OUR DIRECTION AND THAT THIS SURVEY MEETS THE "STANDARDS OF PRACTICE" AS SET FORTH BY THE FLORIDA STATE BOARD OF PROFESSIONAL SURVEYORS AND MAPPERS IN CHAPTER 117, FLORIDA ADMINISTRATIVE CODE, PURSUANT TO SECTION 470.027, FLORIDA STATUTES.  
 LETIER PEREZ & ASSOCIATES, INC.  
 GEOFFREY LETIER, PRESIDENT  
 G.E. PEREZ, PROFESSIONAL SURVEYOR & MAPPER #6395  
 STATE OF FLORIDA

NOT VALID WITHOUT THE SIGNATURE AND THE ORIGINAL RAISED SEAL OF A FLORIDA LICENSED SURVEYOR AND MAPPER.  
 SHEET 1 OF 1